



# PHILIPS

Philips Consumer Lifestyle

BU DA

---

## Consumer Care Book

**GC28xx**

E34

Dry/Travel/Steam irons

Category: Company Confidential  
Author: Tang Teck Kiat  
Date: 2009-Jun-22  
Version: **PV phase**  
Reference: CSB-01-420-08009  
No. of pages: 14 (incl. this page)

---

Approved & signed for Lead Innovation Site, CL DA Singapore

Title : Quality Director

Name : Andreas Loibnegger

Date : 2009-Jun-22

---

Philips Consumer Lifestyle Domestic Appliances Singapore

---

# 1 INTRODUCTION, PLANNING

## 1.1 GENERAL INTRODUCTION



GC2810



GC2820



GC2830



GC2840



GC2860

- **Project description:**
  - The GC2800 will be the successor of the current Powerlife range: GC2500-2600
  - Launch in September 2009 based on S&S PCP max.
- **Main objective**

The Powerlife range is our basic range. The Euro30-45 price range represents 23% of the steam iron market. Historically, we learned that to stay competitive we need to refresh this range every 3 years. We have decided not to upgrade this range which makes a new introduction even more crucial.
- **Objectives:**
  - Increase and protect market share in WE in this price point by strengthening the Durability/Reliability propositions.
  - Breakaway from “just a cheap iron” thought to a strong and clear proposition.
  - Drive sales in Asia (Asia specific range)

## 1.2 IPD MILESTONES

VPD	}	
AA		
PPC		wk840
PV		wk914
CR		wk928
LD		wk936
PE		wk950

### 1.3 STROKE VERSIONS, INTRODUCING REGIONS/COUNTRIES, QUANTITIES, PRICE

TYPE NUMBER	STROKE VERSION	FIRST SHIPMENT	TOTAL PLANNED QUANTITY	FSP	ICOGS	GOING PRICE
GC28XX	GC28XX/02 HV, COATED WITH FUSE / 02	REFER BELOW TABLE	4.4 M OVER 4 YRS	REFER BELOW TABLE	NA	REFER BELOW TABLE

#### Planned quantities as per CMM planning

Region	2009	2010	2011	2012	Average
Europe	429	782	878	522	653/yr
APMEA	304	561	640	381	471/yr
Total	733	1344	1518	903	

#### Price Waterfall (Average of EU, APMEA, LATAM)

Model	GC2810	GC2820	GC2830	GC2840	GC2860	Average
Going Price	€ 35.00	€ 40.00	€ 45.00	€ 50.00	€ 50.00	€ 44.00

## First Shipment & Launch Week per Country

COUNTRIES	12 NC	Introduction			
		Qty	Launch Week	1st Month	2nd Month
France	889281002010	4000	936	8000	16250
	889283002010	2000	936	2000	3000
	889284002010	2000	936	2000	3000
Nordic	889281002190	7500	936	5000	7000
	889283002190	800	936	550	800
	889284002190	700	936	600	500
	889286002190	1000	936	700	1000
Greece	889281002010	250	938	250	300
	889282002010	1000	938	1000	1500
	889284002010	800	938	800	1000
CEE	889281002300	3000	938	3200	4800
	889282002300	1500	938	2000	3000
	889283002300	1500	938	2000	1800
	889284002300	1500	938	2000	2000
South Korea	889281002470	1600	942	1600	1200
	889282002470	1500	942	2500	2500
	889283002470	1500	942	2000	2000
Turkey	889281002010	3000	938	3000	2000
	889282002010	4000	938	4000	3000
	889283002010	2000	938	2000	1500
	889284002010	2000	938	2000	1600
Russia	889281002300	1000	938	2000	2000
	889282002300	1000	938	1500	1000
	889283002300	1000	938	1500	1000
	889284002300	500	938	1500	1000
Iberia	889281002180	8000	936	8000	5500
	889282002180	3000	936	3000	3500
Benelux	889281002010	2000	936	3000	3000
	889282002010	1500	936	3000	2000
	889283002010	2000	936	3000	1000
	889284002010	1500	936	2000	2000
Poland	889282002300	2750	938	2750	2350
	889283002300	2000	938	2000	1500
	889286002300	1500	938	1500	1000
Ukraine	889281002300	1200	936	1200	960
	889282002300	900	936	900	720
	889283002300	500	936	500	400
Germany(swiss)	889282007160	400	936	400	300
	889283007160	400	936	400	300
Dubai	889281002600	4500	942	2500	2000
	889281027600	5500	942	3000	2500
	889282002600	2500	942	1500	1000
	889282027600	3500	942	2000	1500
	889283027600	3500	942	2000	1500
	889286002600	2500	942	1500	1000
Thailand	889286027600	3500	942	2000	1500
	GC2830/02	1500	942	1500	1000
Ireland	GC2860/02	1000	942	1000	700
	GC2810/02	700	936	700	700
Australia	GC2820/02	400	936	400	400
	GC2830/02	300	936	300	300
	889281002530	2640	tbc	tbc	tbc
New Zealand	889286002530	2640	tbc	tbc	tbc
	889281002530	792	tbc	tbc	tbc
	889286002530	792	tbc	tbc	tbc

## 1.4 Customer Service Offering for Consumers

<b>REGION</b>	<b>CSO</b> Front end	<b>CSO</b> Back end	<b>REPAIR PROCESS</b>
<b>APMEA</b>	CALL CENTRE SUPPORT / WEB SUPPORT	CARRY IN/REPAIR	COMPONENT LEVEL REPAIR
<b>EUROPE</b>	CALL CENTRE SUPPORT / WEB SUPPORT	CARRY IN/REPLACEMENT FOR NEW	NO REPAIR
<b>LATAM</b>	CALL CENTRE SUPPORT / WEB SUPPORT	CARRY IN/REPAIR	COMPONENT LEVEL REPAIR

## 2. TECHNICAL SPECIFICATION

### 2.1 KEY SPECIFICATIONS

					
New type numbers	<b>GC2810</b>	<b>GC2820</b>	<b>GC2830</b>	<b>GC2840</b>	<b>GC2860</b>
<b>Price point EUR</b>	<b>35,-</b>	<b>40,-</b>	<b>45,-</b>	<b>50,-</b>	<b>50,-</b>
<b>Soleplate material</b>	Powerglide	Powerglide	Powerglide	Powerglide	Powerglide
Power	2000W	2000W	2100W	2200W	2100W
Continuous steam output	30g	30g	32g	35g	32g
Double Active Calc System	No	yes	yes	yes	yes
Steam boost	Yes	90g	95g	100g	95g
Vertical Steam	no	90g	95g	100g	95g
<b>Drip stop system</b>	yes	yes	yes	yes	yes
Electronic safety shut-off	no	no	no	no	yes
Water door	yes	yes	yes	yes	yes
Steam level control	3 settings	3 settings	3 settings	3 settings	3 settings
cord length	2m	2m	2m	2m	2m
Spray	yes	yes	yes	yes	yes
Pointed Tip	yes	yes	yes	yes	yes
Water tank capacity	270ml	270ml	270ml	270ml	270ml
Pilot lamp	yes	yes	yes	yes	yes
Swivel	360 degrees	360 degrees	360 degrees	360 degrees	360 degrees
<b>Rubber bumper</b>	No	No	Yes	Yes	Yes
Vent pattern	zig zag row	zig zag row	zig zag row	zig zag row	zig zag row

## 2.2 EXPLANATION OF NEW COMMERCIAL FEATURES

Key features to support Reasons to Believe for Durability/Reliability proposition:

- Soleplate with print: New Powerglide coating
- Double Active Calc system: Calc clean filter in water tank + Integrated calc clean in steam slider interface
- Protection against falling: Backplate rubber bumper
- Drip stop feature in full range
- Steam slider design in full range

### Powerlife SS New Features



Existing Powerlife

Zoom in: Calc clean filter

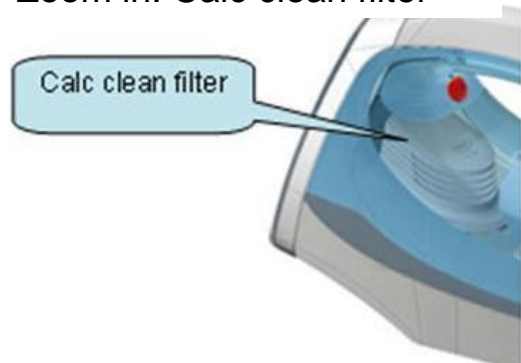

### 3. ARCHITECTURE AND CHARACTERISTICS

#### 3.1 MECHANICAL

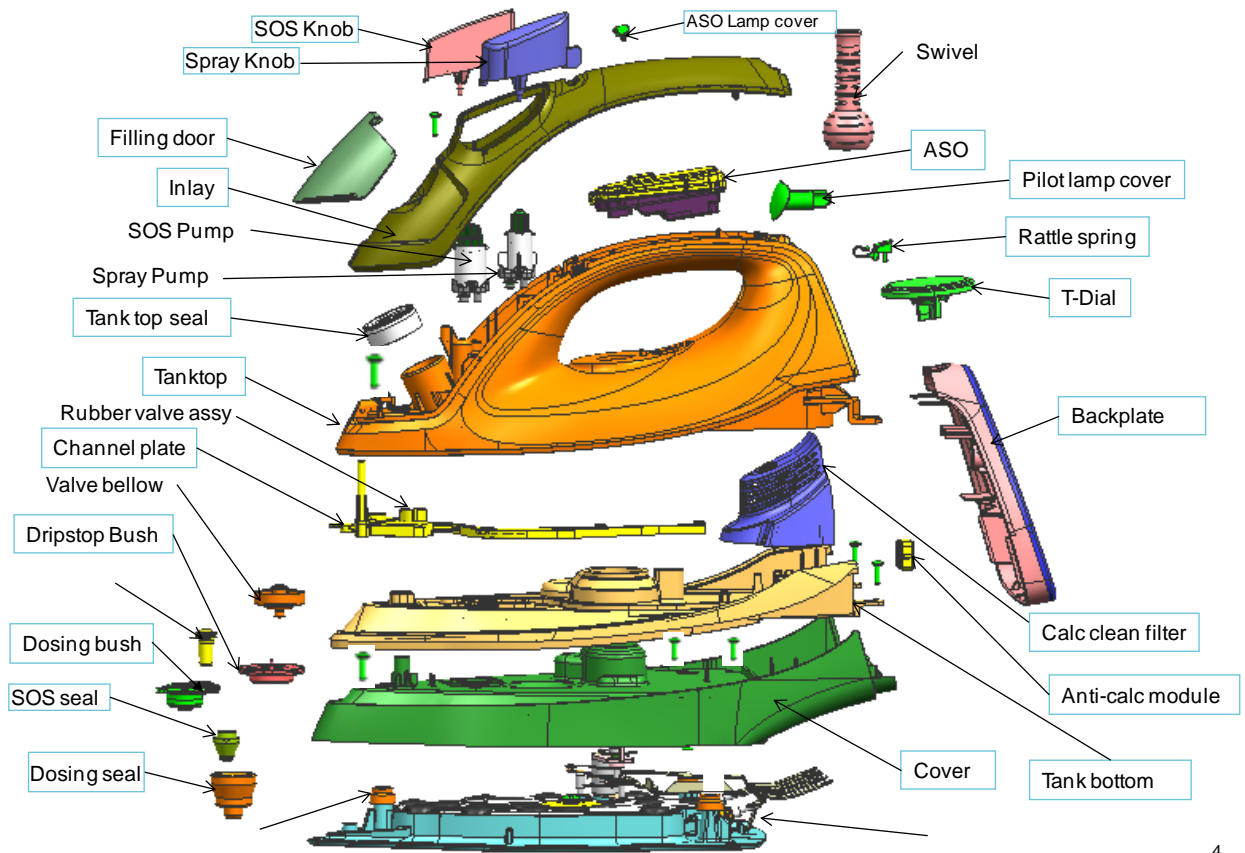

4

#### 3.2 ELECTRICAL BLOCK DIAGRAM

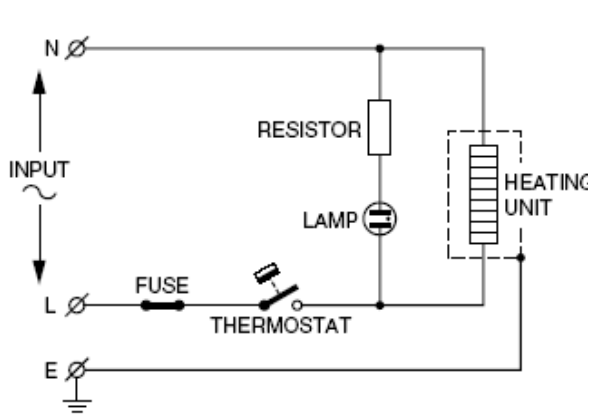

Non ASO version

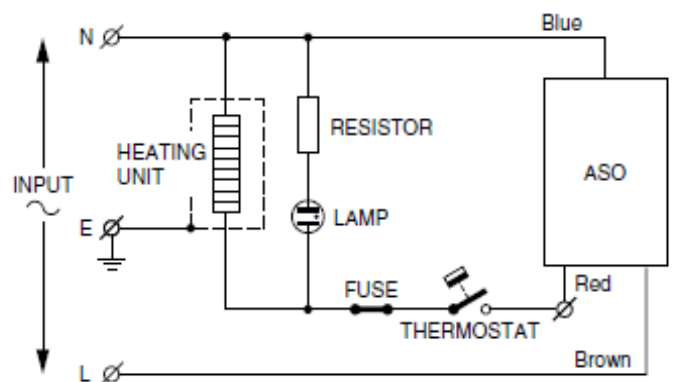

ASO version



## 4. CUSTOMER SERVICE COST PREDICTION

### 4.1 CPI (COST PER INCIDENT) & EXPECTED CALL CENTER COSTS

Region	Labour	Handling & Transport	Parts	Total	Cost per call**	CPI Estimation
<b>APMEA</b> (BASE ON RUN RATE OF MAG E34)	<b>€ 2.64</b>	<b>€ 0.58</b>	<b>€ 2.51</b>	<b>€ 5.73</b>	<b>€ 0.03</b> for mainstream products, 0.15% of sales as rough estimate (ave. NSP: €22.25)	<b>€ 5.76</b>
<b>EUROPE*</b>	<b>€ 0</b>	<b>€ 4.8</b> based on average of Germany: €3, Netherlands: €6.5, France: €5	<b>€ 16.65</b> (Ave. IIP)	<b>€ 21.45</b>	<b>€ 0.05</b> for mainstream products, 0.20% of sales as rough estimate (ave. NSP: €23.78)	<b>€ 21.50</b>

#### \*CPI REPLACEMENT FOR NEW

Country	IIP	Handling & Transport	Total
	(A)	(B)	(A+B)
Germany	Product specific	€3	
Netherlands	Product specific	€6,5	
France	Product specific	€5	

#### \*CPI Repair

Country	Labor	Handling & Transport	Parts consumption	Total
	(A)	(B)	(C)	(A+B+C)
Germany	€10	€8	Product specific	
Netherlands	€13	€6,5	Product specific	
France	€13	€1,5	Product specific	

#### \*\*CALL CENTRE COST GARMENT CARE

- For mainstream products:
  - Use 0.15% of sales for Region APMEA/LATAM
  - Use 0.2% of sales for Region Europe
- For high end products / innovations
  - Use 1% of sales as rough estimate
  - Substantiate by bottom up calculation  
(Call rate ("ACR") \* call duration \* price per minute \* 100) / NSP

## 4.2 CoNQ AS PERCENTAGE OF SALES

$$\left\{ \frac{\text{FCR} \times \text{CPI}}{\text{Net selling price}} \right\} + \left\{ \frac{\text{ACR} \times \text{cost per call}}{\text{Net selling price}} \right\}$$

Region	$\frac{\text{FCR} \times \text{CPI}}{\text{NSP}} + \frac{\text{ACR} \times \text{call cost}}{\text{NSP}}$	CONQ (% of sales)	CONQ (€)
APMEA	$\frac{2.0 \times 5.73}{22.25} + 0.15$	<b>0.67 %</b>	<b>€0.28 mio</b> 4-year volume: 1884K average NSP: € 22.25
EUROPE	$\frac{2.0 \times 21.45}{23.78} + 0.20$	<b>2.00 %</b>	<b>€1.24 mio</b> 4-year volume: 2612K average NSP: € 23.78
TOTAL	NA	<b>1.46 %</b>	<b>€1.52 mio</b>

Note:

FCR = 2.0% (Target at CR)

CPI @APMEA = € 5.73

CPI @Europe = € 21.45

NSP average @APMEA= € 22.25

NSP average @Europe= € 23.78

Call centre cost as % of sales @APMEA = 0.15% (Rough estimate for mainstream products)

Call centre cost as % of sales @Europe = 0.20% (Rough estimate for mainstream products)

### 4.3 TARGET FCR AND KEY COMPONENTS COSTS

Target FCR = **2.0%** @ Commercial Release

Key component costs to be available 1-2 weeks before Industrial Release (Pilot production).

### 4.4 CRITICAL SERVICE PARTS (CSP)

CSPs TO BE ON STOCK AT APC (ASIA PACIFIC PARTS CENTRE) AT LAUNCH DATE OF THE PRODUCT

NO SERVICE PARTS ON STOCK IN EUROPE REGION (EUROSERVICE) AS PRODUCT WILL BE REPLACED FOR NEW DUE TO SERVICE EXCHANGE POLICY

**NO CONSUMER REPLACEABLE PART (CRP) FOR THIS PRODUCT**

Service parts list (Reference GC2860)

Pos	Service code	Description	Remark	Initial order Qty
1	4239 021 52820	Soleplate mounted assy 230V/2000W	CSP	20
2	4239 015 70150	Ryton ring		20
3	4239 026 34230	Cover molded		20
4	4239 026 13220	Thermostat bush		20
5	4239 021 50160	Lamp assy		20
6	4239 015 55800	Tank top seal		20
7	4239 021 50170	Water tank assy - GC2860	CSP	20
8	4239 026 34260	Plastic rattle spring		20
9	4239 021 43960	Spray pump		20
10	4239 021 48990	SOS pump		20
11	4239 020 85140	Valve bellow assy		20
12	4239 021 50220	Steam shaft assy		20
13	4239 015 58300	Dosing seal		20
14	4239 015 58310	SOS seal		20
15	4239 026 34320	SOS knob		20
16	4239 026 34330	Spray knob		20
17	4239 021 51880	Inlay ASO assy		20
18	4239 021 51910	Filling door assy		20
19	4239 026 34370	Backplate Soft Touch		20
20	4239 026 34650	Ball swivel - Snow white		20
21	4239 021 50230	Thermostat dial printed - Eng/Fre		20
22	4239 000 08850	Cord set EU		20
23	4239 010 10290	Insulation sheet		20
24	4239 026 34630	Steam slider		20
25	4239 021 50690	ASO	CSP	20

## 4.5 CHARGE BACK

BACK CHARGE AGREED - **NO**

(REASON: PRODUCTS ARE PRODUCED IN PHILIPS FACTORY SINGAPORE)

## 4.6 FAST FEEDBACK PROGRAM

INFORMATION TO BE DELIVERED BY QPL.

**FAST FEEDBACK REQUESTED? YES**

IN CASE FAST FEEDBACK HAS BEEN REQUESTED:

❖ **EARLY MARKET FEEDBACK? YES**

*Market complaint iron ship-back agreement*

*-Service centre in Germany: Arrivo*

*-Service centre in NL: E-Care*

❖ **REPAIR VIA INITIAL WORKSHOP? YES**  
**QUANTITIES? 100% ANALYSIS**

*-ARRIVO 100% ANALYSIS OF MARKET COMPLAINT IRONS.*

*-Data accessible online via Arrivo Internet site.*

❖ **FIRST 100 CALL CENTRE (SITEL)? YES**

❖ **RAPID EXCHANGE (USA)? NO**

❖ **INTENSIVE FAST FEEDBACK  
SUPPLIER INVOLVEMENT? NO**

## 5. CONSUMER CARE PACKAGE PLANNING

IPD Process Consumer Care Planning - Powerlife Successor GC28xx



★ Target

Timeline (wk)  
PCP Milestone  
IPD Milestone

2008												2009												
40	42	44	46	48	50	52	02	04	06	08	10	12	14	16	18	20	22	23	26	28	30	32	34	36
PO				PC									CES					RfP		RfD				L
PPC													PV					IR		CR				L

### Activities

Consumer Care book approved																									
Consumer Care package review																			★						
Consumer Care package approved																				★					

### Elements of Consumer Care package:

Service readiness	Serviceability report	★			★								★						★						
	Service BOM ready																			★					
	Initial stock CSP confirmation by supplier												★												
	Service manual ready																								
	Sparepart on-stock																								★

Contact Ctr / Web support readiness	Leaflet (draft)												★												
	DFU (draft)												★												
	FAQ (draft)												★												
	Leaflet (Final)																								
	DFU (Final)																								
	FAQ (Final)																								
	Product sample for contact center (SITEL)																								★

PACKAGE	APMEA	EUROPE	REMARK	OWNER
<b>LEAFLET</b>	BY PV	BY PV		CMM
<b>USER MANUAL (DFU)</b>	BY PV	BY PV		CMM
<b>FAQ KNOWLEDGE BASE</b>	BY PV	BY PV		CMM/ARC
<b>SERVICE MANUAL</b>	AT CR	NA		CC
<b>SERVICE BILL OF MATERIAL</b>	BY CR – 2 WK	NA		CC
<b>PRODUCT SAMPLE FOR CONTACT CENTRE</b>	NA	IR + 2 WK; SITEL: 5 SETS		CC

**1) FOR EUROPE, TOLL-FREE SERVICE NUMBER WILL BE ADDED TO WARRANTY BOOKLET.**

<b>Country</b>	<b>New Free phone number</b>	<b>Go live date</b>
France	0805025510	March 1
Spain	900800655	March 10
Germany	08000007520	March 26
Italy	800088774	April 6
UK	08003316015	April 15
Netherlands	08000230076	May 4

**2) FOR EUROPE, TOLL-FREE SERVICE NUMBER WILL NOT BE ADDED TO USER MANUAL AND QUICK START GUIDE.**

**3) FAQ WILL BE TRANSLATED IN TO 10 LANGUAGES**

- English, French, Danish, Spanish, Italian, Dutch (for all version)
- Portuguese (additional for Latam version /55)
- Chinese Simplified (additional for China version /93)
- etc