



HL 1650

HL 1651

HL 1654

HL 1659

[www.philips.com](http://www.philips.com)

In case of complaint contact : Service Manager

Tel. No. 1860-180-1111, 011-6600-1111

For Home Demo contact : 1860-180-1111, 011-6600-1111

ENG	Intelligent mixer grinder, juicer mixer grinder & food processor	1
HIN	इंटेलिजेंट मिक्सर ग्राइंडर और फूड प्रोसेसर	21
TAM	இன்டெலிஜென்ட் மிக்ஸர் கிரைண்டர் அண்ட் ஃபுட் பிராசஸர்	41
MAL	ഇന്റലിജെന്റ് മിക്സർ ഗ്രൈന്ററും ഫുഡ് പ്രോസസറും	61

**Philips Electronics India Limited.**

7, Justice Chandra Madhab Road, Kolkata - 700 020

**In case of complaint contact :** Service Manager

Address : As above (Tel. No. 1860-180-1111, 011-6600-1111)

For Home Demo contact : 1860-180-1111, 011-6600-1111

[www.philips.com](http://www.philips.com)



100% recycled paper

**PHILIPS**

## Table of contents

1.0	Introduction	2
1.1	Important	3
2.0	General description	5
3.0	Product features	6
4.0	Before first use	7
5.0	Preparing for use	7
6.0	Using the appliance	7
6.1	Mixer grinder without timer (HL 1650)	7
6.2	Mixer grinder with timer (HL 1651)	9
6.3	Juicer mixer grinder without timer (HL 1654)	10
6.4	Food processor (HL 1659)	12
7.0	Tips	14
8.0	Cleaning	18

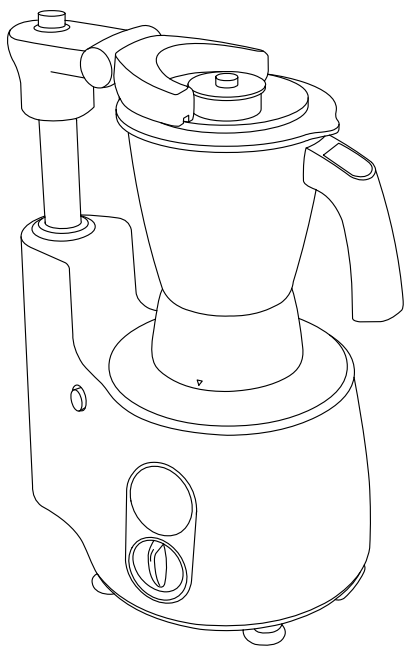

## 1.0 Introduction

1.1 Philips brings to you, yet another unique collection of products called Philips Intelligent Mixer Grinder (HL 1650), Philips Intelligent Mixer Grinder with timer (HL 1651), Juicer Mixer Grinder (HL 1654) and Philips Intelligent Food Processor (HL 1659), which showcase exemplary features that make your life more convenient and contemporary.

1.2 They come with an Intelli Arm that completely assures the locking mechanism of the jar's lid. An Intelli Control that sets the time for the machine and gives a lock feedback and auto shutoff feature, which ensures that the machine shuts off automatically once the set time is over. These distinct features give you total freedom, to leave the machine and do your work at ease.

## 1.1 Important

We strongly recommend that you read the following instructions carefully, before using the appliance and save them for future reference:

- Check if the voltage indicated on the base of the appliance, corresponds to the local electrical mains voltage, before you connect the appliance
- Always use a properly earthed electrical connection
- Do not use the appliance when the mains cord, the plug or other components are damaged
- If the mains cord is damaged, do not use the appliance and contact the nearest Philips service centre
- This appliance is strictly for household use
- Keep the appliance out of children's reach
- Never use accessories or parts that are not recommended by Philips or made by other manufacturers
- Your guarantee will become invalid, if you use such parts or accessories
- Check sieve, fruit filter and blades every time you want to use the appliance. If you detect any cracks or damage, do not use the appliance and contact the nearest Philips service centre
- Make sure all parts are correctly mounted before you switch on the appliance
- Only use the appliance when jar and arm are locked
- Do not remove the pulp container when the appliance is in operation (HL 1654)
- Do not touch the small cutting blades in the base of filter (HL 1654)
- For application times, see the table on instructions for use manual
- Thoroughly clean the parts that will come in contact with food before you use the appliance for the first time
- Do not exceed quantities and preparation times indicated in the table
- Switch off the appliance and disconnect for supply before detaching any accessory or approaching parts that move in use
- Always switch off the appliance by turning the speed knob to zero position
- Always unplug the appliance after use
- Never immerse the motor unit in water or any other liquid. Do not rinse it either
- Never lift the product holding the arm or its guide
- Never forcefully lift the appliance without releasing the vacuum using the lever (Fig.58, HL 1659)
- Do not use the jars as storage containers
- During food processing/juicing operation, never use your fingers or an object (E.g. spatula) to push ingredients down the feed tube while the appliance is running. Only the pusher is to be used for this purpose (HL 1654, HL 1659)
- Always unplug the appliance before reaching into any jar including juice collector
- Always ensure that the speed selector knob is at '0' position, before fixing accessories for liquidizing/blending, use speed 1 only
- Keep Mixer away from hot gas burner or electric hot plate or similar appliances
- Do not use Mixer on wet surface
- Use Mixer on smooth surface without any gaps for effective vacuum grip
- For non-timer versions, do not use Arm or accessories as switch, to start/stop the appliance
- Never try to remove accessories without pressing the 'button to unlock accessories'

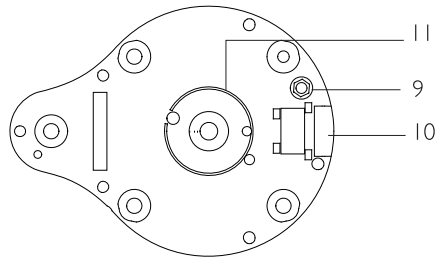
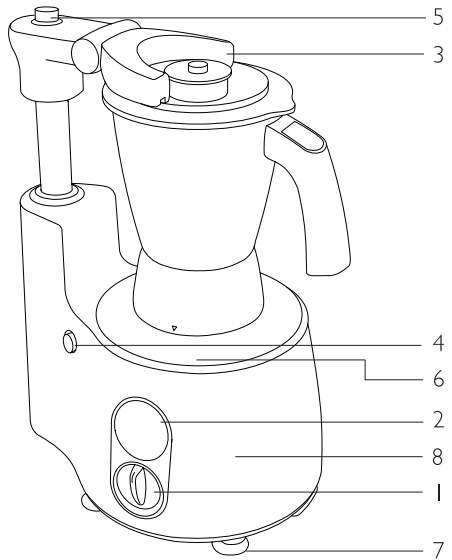

HL 1659

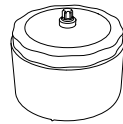

17

HL 1659

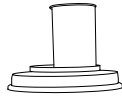

18

HL 1659



19

HL 1659



20

HL 1659



21

HL 1659



22

HL 1659



23

HL 1659



24

HL1650  
HL1651  
HL1659



12

HL 1659

HL1650  
HL1651  
HL1654  
HL1659

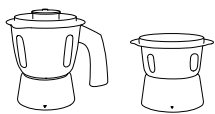

13

HL 1654-59

HL 1654



25

HL 1654

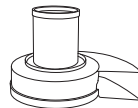

26

HL 1654



27

HL 1654



28

## 2.0 General description

1. Speed selector knob
2. Intelli Control (HL1651, HL1659)
3. Intelli Arm
4. Button to unlock the jar
5. Button to unlock and move the arm
6. Guide for jar lock
7. Anti slip rubber feet
8. Motor unit
9. Overload protector at the bottom
10. Lever to release the vacuum (HL1659)
11. SuperVacuugrip (HL1659)
12. 1 steel jar (Wet grinding) (HL1650, HL1651, HL1659)
13. 2 steel jars (Dry grinding and chutney)
14. Food Processor bowl (HL1659)
15. Blender jar with fruit filter (HL1654, HL1659)
16. a) Lid with feeding tube b) Juice collector
17. Gear unit – To reduce the speed (HL1659)
18. Feeding tube (HL1659)
19. Pusher (HL1659)
20. Tool holder to fix food processor blades (HL1659)
21. Adjustable slicing disc - 7 level slicing blade (HL1659)
22. Chopping or mincing blade with protective cover (HL1659)
23. Kneading blade (HL1659)
24. 2 size grating inserts – Fine and medium (HL1659)
25. Pusher (HL1654)
26. Feeding tube (HL1654)
27. Sieve (HL1654)
28. Pulp container (HL1654)

### 3.0 Product features

**Intelli Control:** (HLI 651, HLI 659) This Intelli Control/Timer comes with an Intelli Lock feedback that provides safety for the entire appliance. Intelli Shutoff, ensures that once you set the timer, it will complete the operation and automatically close down, even in your absence.

This function also enables you to select the Auto or Manual mode. (Fig. 1)

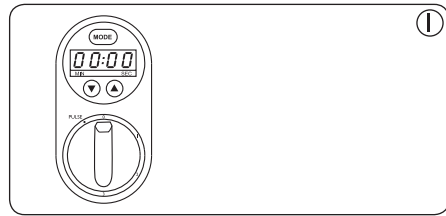

**Intelli Arm:** The Intelli Arm with Intelli Lock gives you the freedom to move, while your appliance is still working. It also acts like a safety mechanism and avoids spillage of ingredients. (Fig. 2)

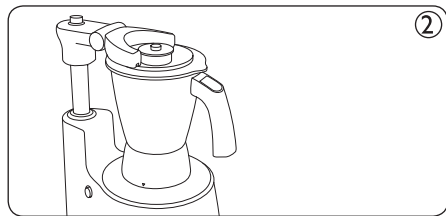

While an appliance is not in use, you can fold down the arm. This arm can also be rotated anticlockwise only for ease of fixing accessories.

**Big chute:** (HLI 654) This juicer has an extra large feeding tube, which means that you do not have to pre cut or chop the fruit or vegetables before hand. (Fig. 3)

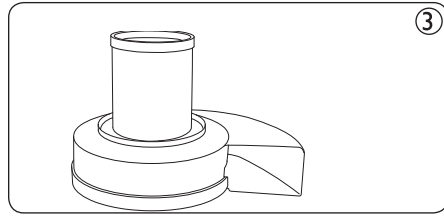

**Super Vacuugrip:** This unique grip ensures that the appliance stays fixed in its position, while it is being used. It provides you complete peace of mind and liberty to do other tasks. (Fig. 4)

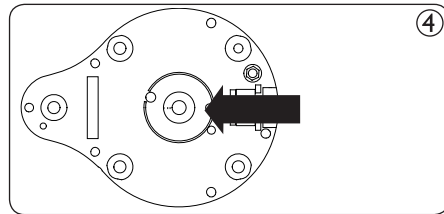

**Super Silent 750W motor:** It comes with a Super Silent Motor, with 750W and ensures that everything gets well grounded, with minimal noise. (Fig. 5)

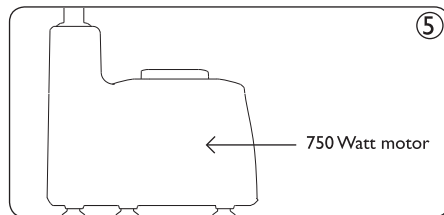

**Super Grind:** It has reverse Quadra Flow jars along with lift and grind blades that ensure that grinding is done, just the way you want it. (Fig. 6)

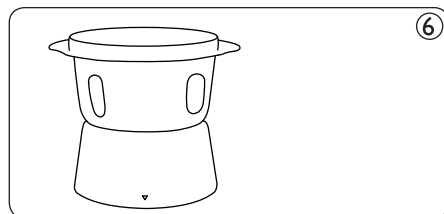

### 4.0 Before first use

We suggest that you thoroughly clean the parts that come in contact with food, before using the appliance for the first time. (Fig. 7)

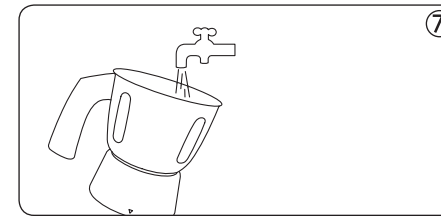

### 5.0 Preparing for use

- Let the hot ingredients cool down, before putting them in the jars (Fig. 8)

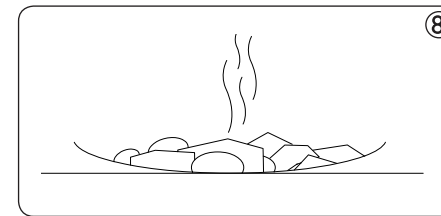

- Cut large ingredients into pieces of approximately 2 cm. before processing them (Fig. 9)

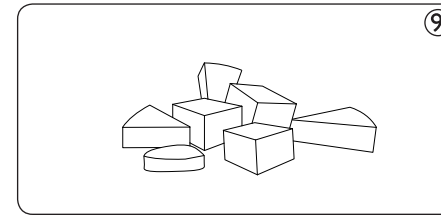

- Assemble the appliance properly, before putting the plug into the socket

### 6.0 Using the appliance

#### 6.1 Mixer grinder without timer (HL 1650)

Follow these simple steps to use the appliance easily:

1. Connect the main plug to the wall socket (Fig. 10)

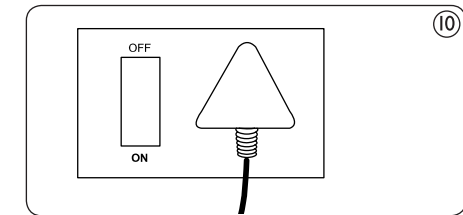

2. Fix the jar on the motor unit, with the help of arrow on the jar collar and motor unit (Fig. 11)

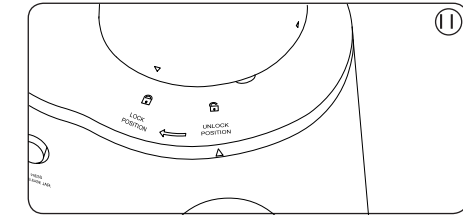

3. Switch on the main supply (Fig. 12)

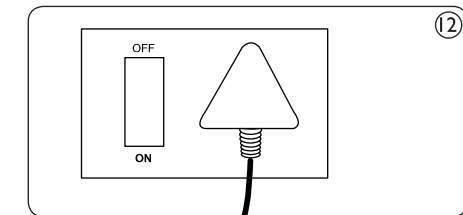

4. A neon lamp will light up to indicate the power supply is on (Fig. 13)

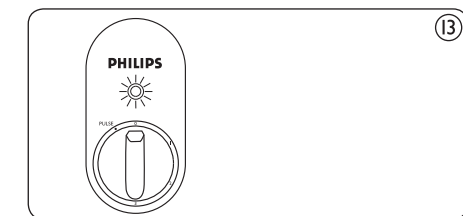

5. While fixing the arm on the jar, ensure that the groove in arm, matches with the circular ring on lid (Fig. 14)

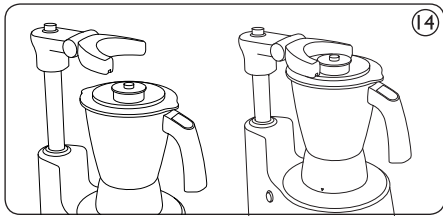

6. Turn the speed selector to the required position. Select the speed to suit the recipe (Fig. 15)

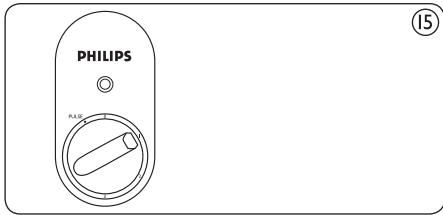

7. After operation, turn selector knob to 'Off' position (Fig. 16)

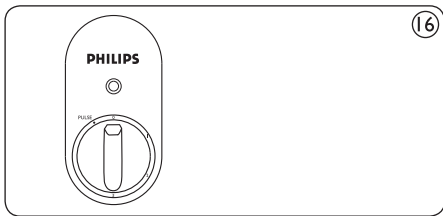

8. For pulse, turn speed selector knob anticlockwise from '0' position gently

9. Pull the arm in upward direction. Press the button to move the arm upwards (Fig. 17)

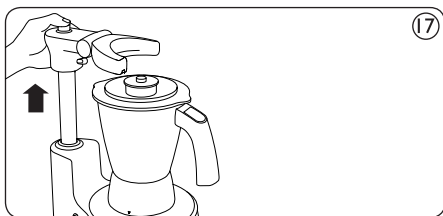

10. Finally press the button to unlock the jar (Fig. 18)

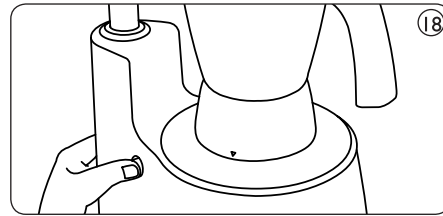

## 6.2 Mixer grinder with timer (HL 1651)

1. Connect the main plug to the wall socket (Fig. 19)

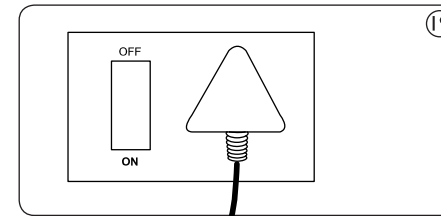

2. Switch on the main supply  
3. LED display will show --- indicating the power supply is on (Fig. 20)

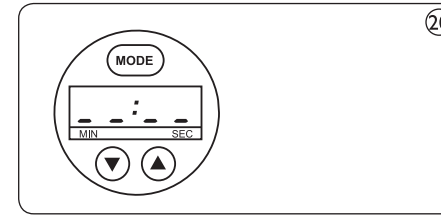

4. Fix the jar on the motor unit, with the help of the arrow on the jar collar and motor unit. The LED display will change to 00:-- (Fig. 21)

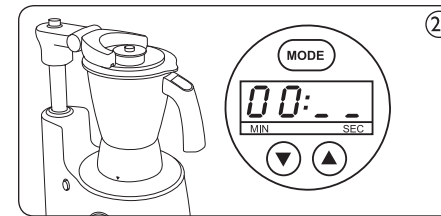

5. Fill the jar with the ingredients and put the lid (Fig. 22)

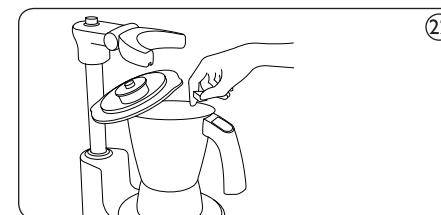

6. Fix the arm on the jar. The LED display will change to 00:00. This indicates that the appliance is ready to use (Fig. 23)

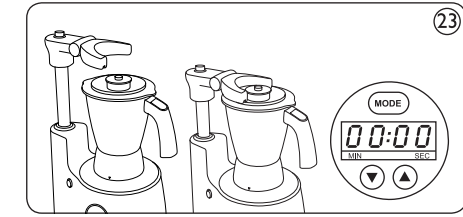

7. Default mode of the operation is 'Auto.' To go on to the Manual mode, press the mode button. The LED display will now change (Fig. 24)

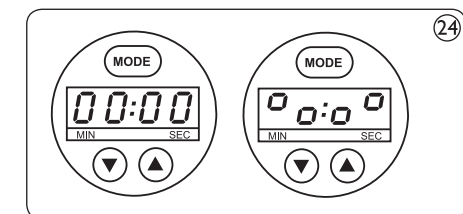

8. Set the time using Up and Down arrows. Maximum time that can be set is 30 minutes (Fig. 25)

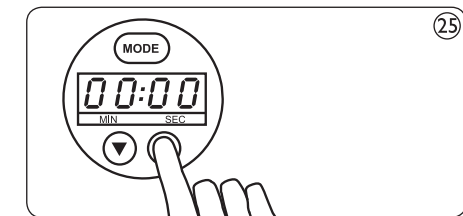

Note: The appliance will auto shutoff after 5 minutes (Auto mode) and 3.5 minutes (Manual mode) of continuous operations, to avoid any unforeseen situation. In case, the appliance doesn't start within 5 minutes after setting the time OR stops in between, and is not restarted within 5 minutes, the display will reset to 00:00

9. Turn the speed selector knob to the required position. Select the speed to suit the recipe (Fig. 26)

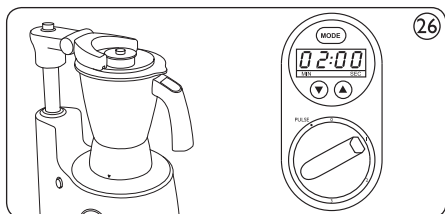

10. After operation, the appliance will stop on its own  
 11 Turn speed selector knob to 'Off' position (Fig. 27)

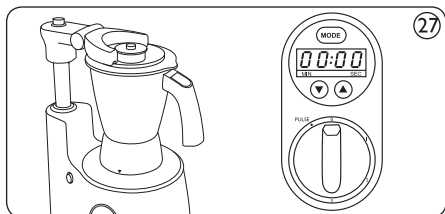

12. Press the button above the arm, to pull it in upward direction (Fig. 28)

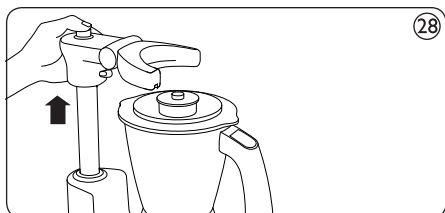

13. Press the button to unlock the jar (Fig. 29)

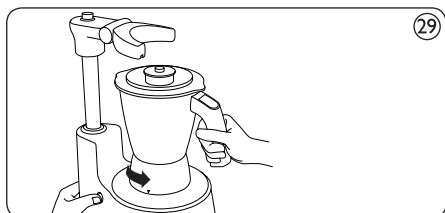

### 6.3 Juicer Mixer Grinder (HL 1654)

1. Connect the mains plug to the mains socket (Fig. 30)

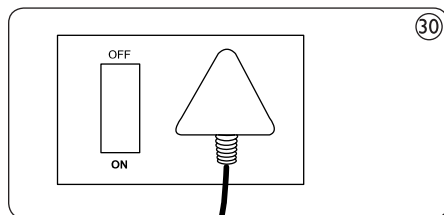

2. Switch on the mains supply  
 3. A neon lamp will light up to indicate the power supply is on (Fig. 31)

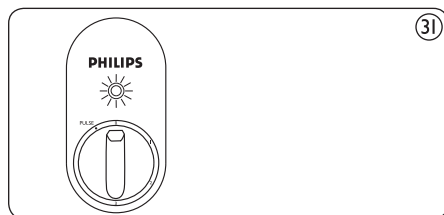

4. Fix the juice collector into the appliance and then turn it clockwise until you hear a click sound (Fig. 32)

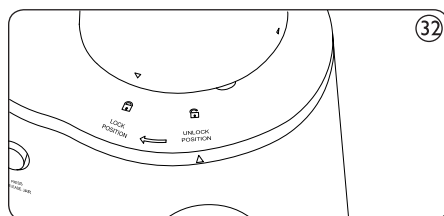

5. Place the pulp container into the appliance by tilting it forward slightly. Insert the top end first and then push the bottom end. While you are preparing the juice, you can empty the pulp container by switching the appliance off and carefully removing the pulp container

Note: Reassemble the empty pulp container before you continue juicing

6. Put the filter in the juice collector. Make sure the filter is fitted securely onto the driving shaft

Always check the sieve before use. If you detect any cracks or damage do not use the appliance and contact the nearest Philips service centre or take the appliance to your dealer (Fig. 33)

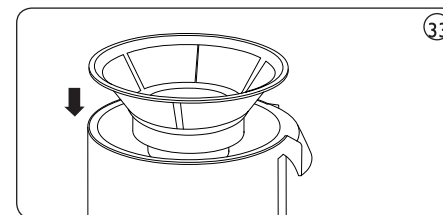

7. Hold the lid over sieve and lower it into position  
 8. Fix the arm on the lid till you hear a click (Fig. 34)

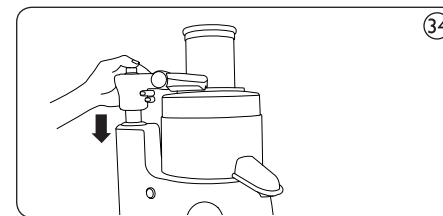

9. Turn speed knob to position 1 or 2 (Fig. 35)

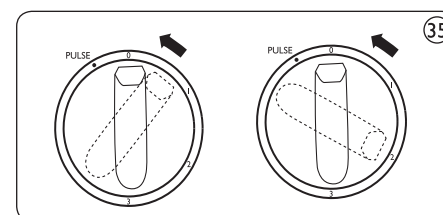

- Note : While juicing, appliance will not work in speed knob position 3  
 10. Place the container under the spout (Fig. 36)

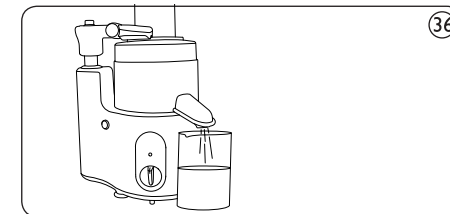

11. Put the fruit in the feeding tube and gently slide the pusher into the feeding tube by aligning the groove in the pusher with the small protrusion on the inside of the feeding tube (Fig. 37)

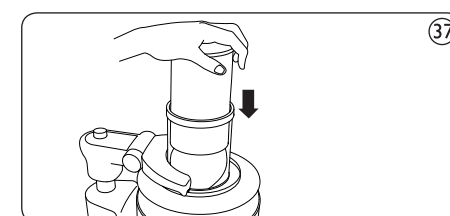

- Do not exert too much pressure on the pusher, as this could affect the quality of the end result and could even cause the filter to come to a halt. Never insert your fingers or an object into the feeding tube  
 12. Turn speed selector knob to 'Off' position and wait until the filter has stopped rotating. Remove the pusher (Fig. 38)

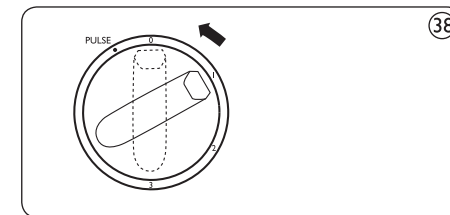

13. Press the button above the arm, to pull it in upward direction

## 6.4 Food processor (HL 1659)

1. Connect the main plug to the wall socket
2. Switch on the main supply (Fig.39)

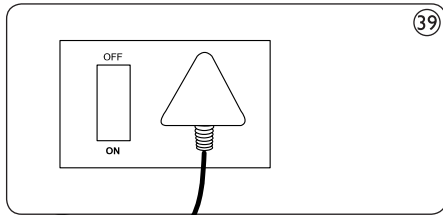

3. LED display will show ---:-- indicating the power supply is on (Fig. 40)

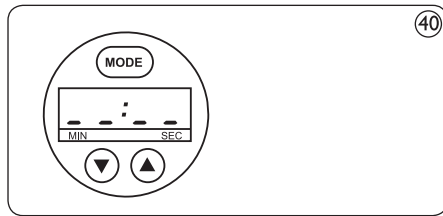

4. Fix the gear box of the food processor and then turn it clockwise until you hear a click. The LED display will change to 00:-- (Fig.41)

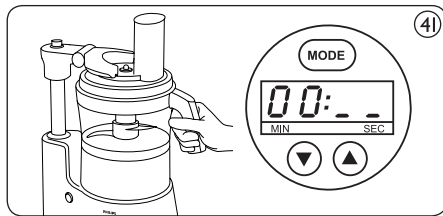

5. Put the bowl, followed by tool holder along with the required food processor blade and then place the lid on the bowl. Then fit the arm on the lid until you hear a click. The LED display will change to 00:00 This is an indication that the appliance is ready to use (Fig.42)

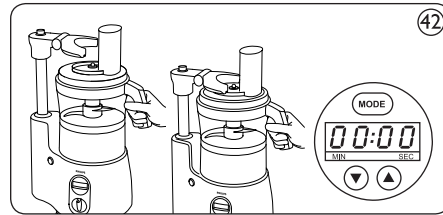

6. Default mode of the operation is 'Auto.' To go on to the Manual mode, press the mode button. The LED display will now change (Fig. 43)

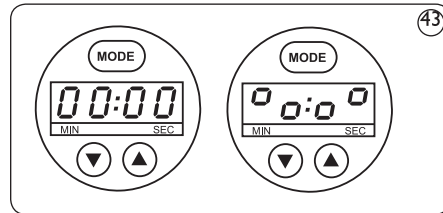

7. Set the time using Up and Down arrows. Maximum time that can be set is 30 minutes (Fig. 44)

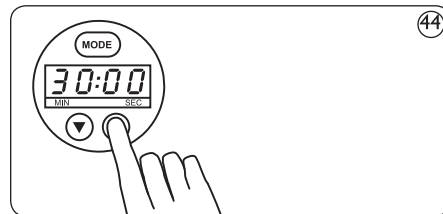

- Note: The appliance will auto shutoff after 5 minutes (Auto mode) and 3.5 minutes (Manual mode) of continuous operations, to avoid any unforeseen situation. In case, the appliance doesn't start within 5 minutes after setting the time OR stops inbetween, and is not restarted within 5 minutes, the display will reset to 00:00
8. Turn the speed selector knob to the required position. Select speed 1 for food processing application (Fig. 45)

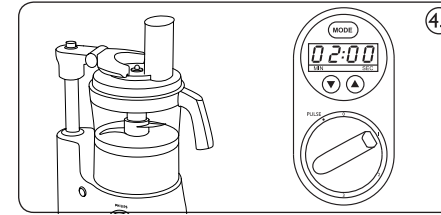

9. After operation, appliance will stop on its own
10. Turn speed selector knob to 'Off' position (Fig. 46)

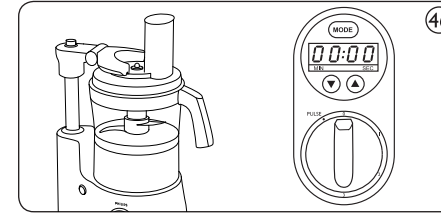

11. Press the button above the arm, to pull it in upward direction (Fig. 47)

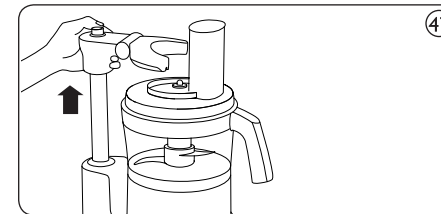

12. To use the metal blade, remove the protective covering from the blade (Fig. 48)

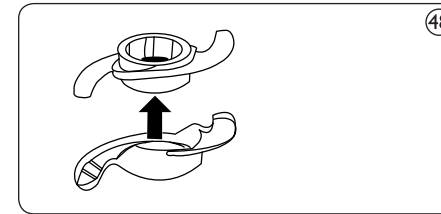

- Note: The cutting edges of the blade are very sharp. Avoid touching them.

13. Use the feed tube to add liquid and/or solid ingredients. Pre-cut large pieces of food into pieces of approximately 3x3x3 cms. (Fig. 49)

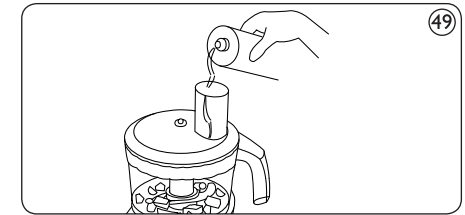

14. Use the pusher to push solid ingredients through the feed tube. Fill the feed tube evenly for best results (Fig. 50)

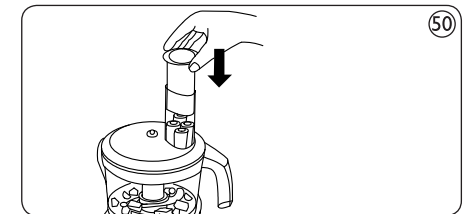

15. You can also use the pusher to close the feed tube in order to prevent ingredients from escaping through the feed tube (Fig.51)

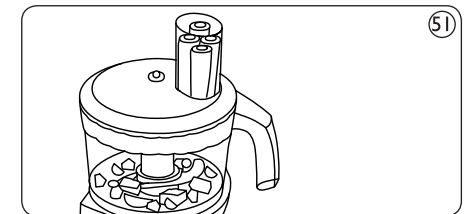

16. Never process hard ingredients like ice cubes with the inserts

17. To use the grating insert, put the selected insert in the insert holder before you place it onto the tool holder. Put the insert holder onto the tool holder that stands in the bowl (Fig. 52)

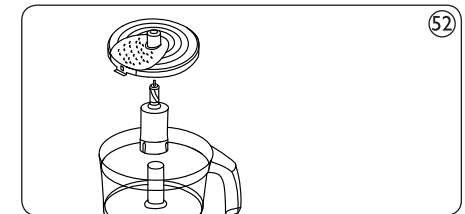



18. To remove the inserts from the insert holder, take the insert holder in your hands with its back pointing towards you. Push the edges of the insert with your thumbs to make the insert fall out of the holder. Cutting edges are sharp. Avoid touching them.

19. The adjustable slicing disc allows you to cut ingredients to any thickness you like. Twist the holder on the base of the disc to get the required thickness. Be careful, as the cutting edges of blade are very sharp (Fig. 53)

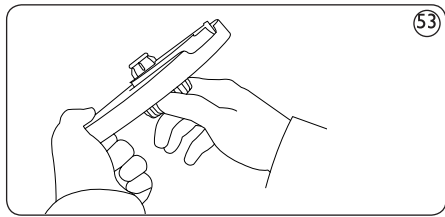

#### Built in safety lock:

- The appliance is provided with safety system. It ensures that the appliance will not start until any accessory is properly fixed, i.e. the lid is placed and the arm is holding the lid properly (Fig. 54)

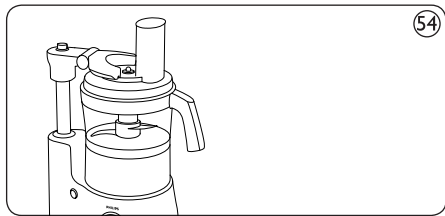

- While the motor is running, if the arm is lifted or an accessory is unlocked, the appliance will stop working automatically

## 7.0 Tips

### Handy tips for effective use:

- The lid of the wet and blender jar has a cap. By opening this cap, you can check the content to add water etc. Hence there is no need to open the lid (Fig. 55)

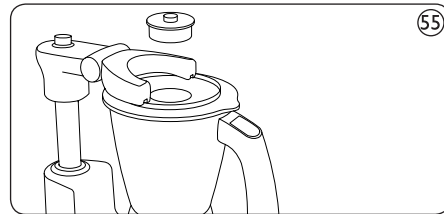

- Don't remove the arm while the application is still on, as this will result in Auto shut off. The LED will show (Time remaining) 02:AE (Fig. 56)

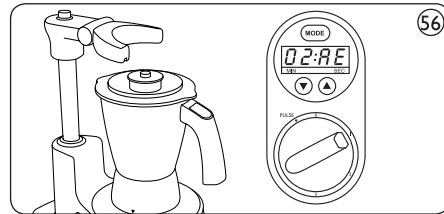

- Don't unlock the jar while the application is still on, as this will result in Auto shut off. The LED will show JE:02 (Time remaining) (Fig. 57)

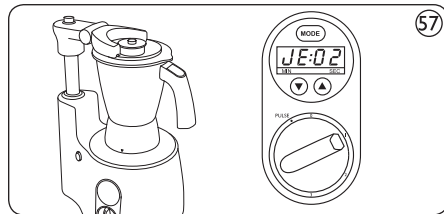

- If both, arm and jar are removed during the operation, the LED will show JE:AE (Fig. 58)

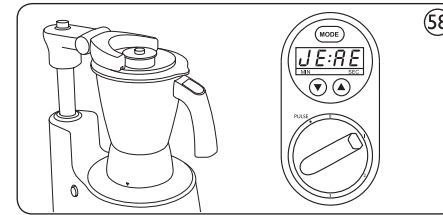

- After the arm is placed again and/or jar is locked again, remaining time is displayed. To restart the operation, bring back speed selector knob to '0' position and then turn it clockwise to the required speed position (Fig. 59)

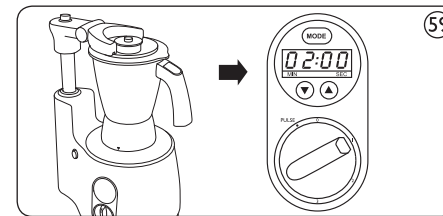

- In order to avoid motor burning due to overloading, this appliance is fitted with power shut off mechanism. So, if it sometimes stops due to overloading, the red knob at the bottom will come out by itself. This function warns you about the overloading of your appliance. Simply switch off the appliance in such a case. Remove the excess load from the jar. Now wait for 2-3 minutes. Then press the red knob at the bottom of the appliance and start the appliance. The appliance will start working again (Fig. 60)

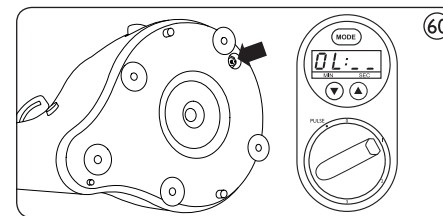

- All applications carried out in the food processing bowl, should be done at 'Speed 1' (Fig. 61)

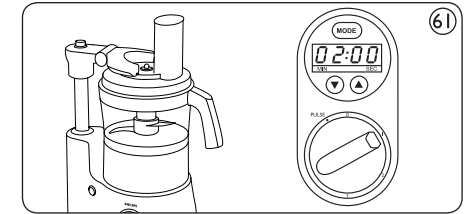

- During the operations, if the appliance is switched off, the remaining set time will stay in the memory of the appliance (Not more than 5 minutes). This ensures that the operation is completed by the set time only (Fig. 62)

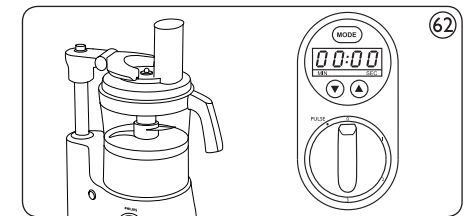

- If there is a power failure, the appliance will come to default setup
- In between the operation, if the set time needs to be cancelled, bring the speed selector switch to '0' position and then press the mode button twice. (Pressing mode button only once will bring the appliance to manual mode) follow the steps to set the new timings (Fig. 63)

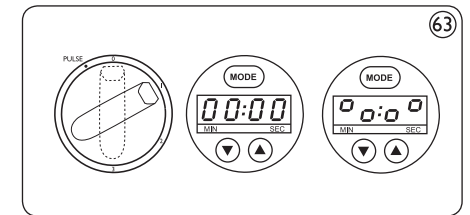

- In between the operation, if set time needs to be changed, bring the speed selector switch to '0' position and press Up and Down arrows (Fig. 64)

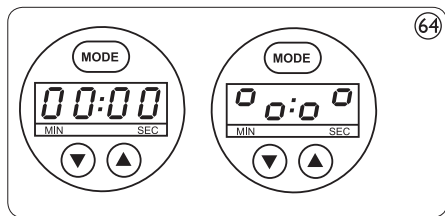

- If you want to chop onions, stop the appliance after four pulses to prevent them from becoming too finely chopped
- Do not let the appliance run too long, when you are chopping (Hard) cheese. The cheese will become too hot, will start to melt and will then turn lumpy
- Do not use the blade to chop very hard ingredients like coffee beans, turmeric, nutmeg and ice cubes, as this may cause the blade to get blunt (Fig. 65)

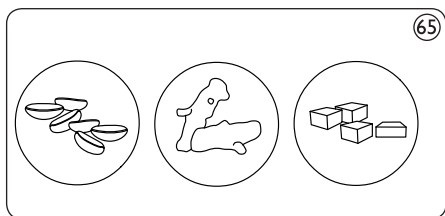

- Always use speed I for food processing. If food sticks to the blade or to the inside of the bowl : (Fig. 66)

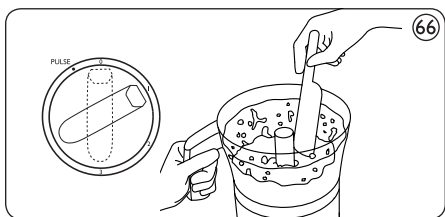

- Turn the appliance off
  - Remove the lid from the bowl
  - Remove the ingredients from the blade or from the wall of the bowl with a spatula
- For effectiveness of vacuum pad: Before every use, pull 'lever to release vacuum' and then push the appliance down. In this position, release the lever (Fig. 67)

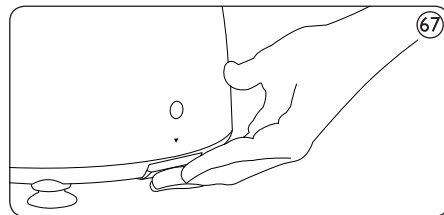

- Never try to turn the speed selector knob forcefully anticlockwise after pulse position and clockwise, after '3' position. This will damage the knob (Fig. 68)

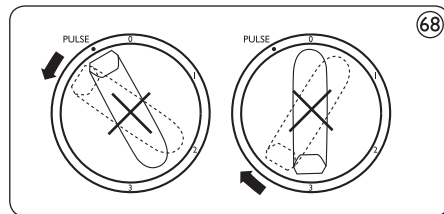

- Use fresh fruits and vegetables as they contain more juice. Pineapples, beetroots, celery stalks, apples, cucumbers, carrots, spinach, melons, tomatoes, pomegranates, oranges and grapes are particularly suitable for processing in the juicer extractor (Fig. 69)



- You don't have to remove thin peels or skins. Only thick peels, e.g. those of oranges, pineapples and uncooked beetroots need to be removed. Also remove the white pith and seeds of citrus fruits because it has a bitter taste
- When preparing apple juice, remember that the thickness of juice depends on the kind of apple you are using. The juicier the apple, thinner the juice. Choose a kind of apple that produces type of juice you prefer
- Apple juice turns brown very quickly. You can slow down this process by adding a few drops of lemon juice (Fig. 70)

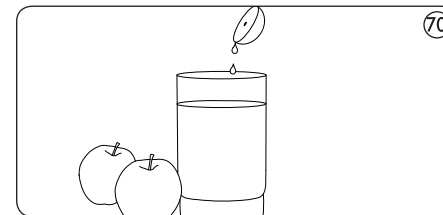

- Fruits that contain starch such as bananas, papaya, avocados, figs, guava and mangoes are not suitable for processing in the juicer extractor. Use a food processor, blender or bar blender to process these fruits (Fig. 71)

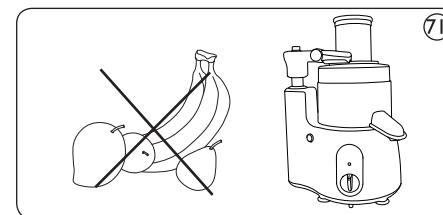

- Leaves and leaf stalks of e.g. lettuce can also be processed in the juicer extractor (Fig. 72)

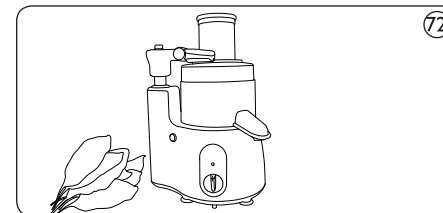

- Drink the juice immediately after you have extracted it. If it is exposed to air for some time, the juice will lose its taste and nutritional value
- To extract the maximum amount of juice, always press the pusher down slowly
- The juicer is not suitable for processing very hard and/or fibrous/starchy fruits or vegetables such as sugarcane, amla (Emblica officinalis) (Fig. 73)

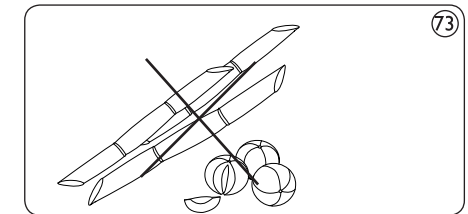

## 8.0 Cleaning

- Always unplug the appliance before you remove the accessories or clean the motor unit
- The appliance is easier to clean immediately after use (Fig. 74)

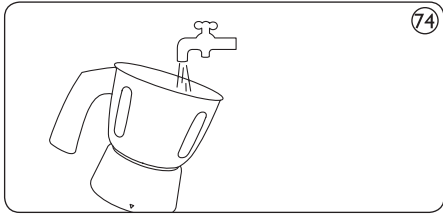

- Remove the main plug from the wall socket (Fig. 75)

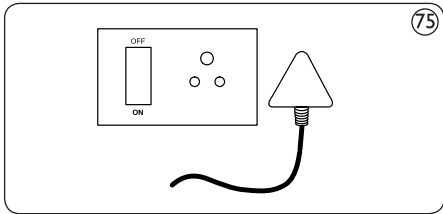

- Do not immerse the motor unit in water (Fig. 76)

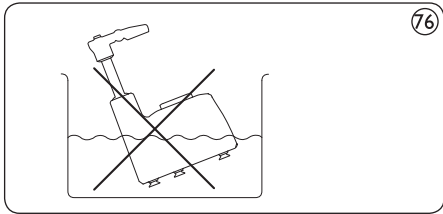

- Clean the basic unit with damp cloth only (Fig. 77)

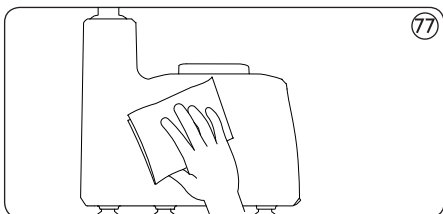

- Do not use abrasive cleaning agents, scourers, acetone, alcohol etc. to clean the appliance (Fig. 78)

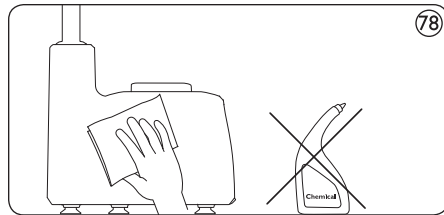

- Disassemble the other parts after each use and wash them in soapy water (Fig. 79)

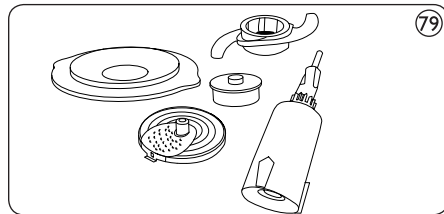

- Then rinse with clean water and dry thoroughly (Fig. 80)

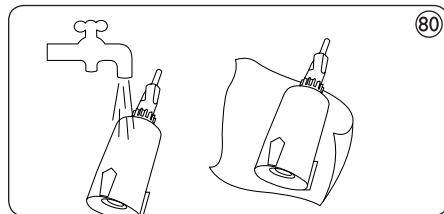

- The bowl, the lid of the bowl, the pusher and the accessories (Except for the blender jar) can also be cleaned in a dishwasher
- Clean the metal blade, the blade unit of the blender and the inserts very carefully. Their cutting edges are very sharp!
- Make sure that the cutting edges of the blades and the inserts do not come into contact with hard objects. This could cause them to become blunt
- Remove the used parts from the motor unit. Disassemble the appliance in the following order: Remove pulp container;

remove pusher; remove the arm and remove the lid (Fig. 81)

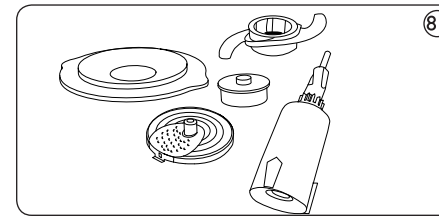

- Remove the juice collector together with the sieve
- Clean sieve with the cleaning brush in warm water with some washing-up liquid and rinse them under the tap (Fig. 82)

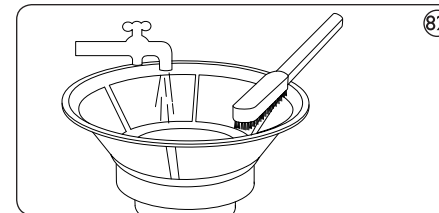









- You can quickly and easily pre-clean jars and Food Processor bowl using PULSE position. Simply add water and washing up liquid to the dirty bowl or jar and secure lid followed by Arm. Then turn speed knob to PULSE Position and hold it until jar or bowl is clean. When you pre-clean bowl or jar this way, make sure the blade or kneading accessory is assembled

Model : HLI650/HLI651/ HLI654/HLI659  
Voltage : 230V 50Hz  
Wattage : 750W  
Normal load: Refer standard Recipes

Standard Recipes:(Quantity and Time Schedule)

S.No.	Recipe	Quantity	Time	Load	Speed
1	Urad dal	200gms + 450ml water soaked for 8~10hours. Add 50ml water	90secs.	675W	High
2	Rice	250gms + 280ml water soaked for 8~10hours. Add 50ml water	120secs.	500W	High
3	Haldi	150gms roasted, cooled and pounded in to 1" pcs.	120secs.	450W	High
4	Wet masala	250gms onion+175gms tomato+green chili (3 nos.)	60secs.	350W	High
5	Milk shake	400ml milk+50gms ice cream(Optional)+40gms strawberry crush (Sugar as per taste)	60secs.	350W	Low
6	Sambar masala	105gms coriander seeds+20gms chana dal+20gms methi seeds+5gms red chilies.Roasted and cooled	60secs.	500W	High
7	Garam masala	75gms clove+75gms cinnamon+75gms black pepper+10gms masala cardamom, lightly roasted and cooled	90secs.	625W	High

Function	Accessory	Application	Application time	Speed
		Chopping, mincing	10 - 60secs.	Low
		Shredding, grating	10 - 60secs.	Low
		Slicing	10 - 60secs.	Low
		Kneading, mixing	60 - 180secs.	Low

**Important:**

- For Liquidizing/Blending/Juicing/Food processing use speed 1 only
- For wet/dry/chutney grinding, use speed 1 and speed 2 for 10~15 seconds only. Thereafter use speed 3 till you finish grinding.
- Recommended quantity for juicing. Maximum quantities of fruit that can be juiced in juicer at one go is 2Kg. Then clear the pulp chamber. Between juicing different fruits it is advisable to pour 100ml. water through sieve. This cleans the sieve and removes the taste of the previous juice
- Note - For obtaining maximum juice output and stable operation of juicer; the above listed quantity of fruit can be juiced without in-between cleaning of the appliance
- Note - Juicing can be continued after cleaning the juice collector; pulp container and filter for obtaining highest efficiency of the appliance