

**PHILIPS**

Pet air purifier

AC3681



# User manual

# Contents

<b>1</b>	<b>Important</b> .....	<b>2</b>
	Safety .....	2
	Electromagnetic fields (EMF) .....	4
	Recycling .....	4
<b>2</b>	<b>Your pet air purifier</b> .....	<b>5</b>
	Product overview .....	5
	Controls overview .....	6
<b>3</b>	<b>Getting started</b> .....	<b>7</b>
	Installing the filter .....	7
<b>4</b>	<b>Using the air purifier</b> .....	<b>9</b>
	Understanding the air quality light .....	9
	Turning on and off .....	9
	Changing the mode setting .....	10
	Setting the pet lock .....	11
	Automatic floating hair cleaning .....	11
<b>5</b>	<b>Cleaning and maintenance</b> .....	<b>13</b>
	Cleaning the body of the air purifier .....	13
	Cleaning the particle sensor .....	13
	Cleaning the filters .....	14
	Replacing the filter .....	15
	Filter reset .....	18
<b>6</b>	<b>Storage</b> .....	<b>18</b>
<b>7</b>	<b>Troubleshooting</b> .....	<b>19</b>
<b>8</b>	<b>Warranty and support</b> .....	<b>21</b>
	Order parts or accessories .....	21

# 1 Important

---

## Safety

Read this user manual carefully before you use the appliance, and save it for future reference.

## Danger

- Do not let any liquid or flammable detergent enter the appliance, to avoid electric shock and/or a fire hazard.
- Do not spray any flammable materials such as insecticides or fragrance around the appliance.

## Warning

- Check if the voltage indicated on the appliance corresponds to the local mains voltage before you connect the appliance.
- If the supply cord is damaged, you must have it replaced by Philips, a service center authorized by Philips, or similarly qualified persons in order to avoid a hazard.
- Do not use the appliance if the plug, the power cord, or the appliance itself is damaged.
- This appliance can be used by children aged from 8 years and above under supervision. This appliance can be used by persons with reduced physical, sensory or mental capabilities or lack of experience and knowledge if they have been given supervision or instruction concerning use of the appliance in a safe way and understand the hazards involved.
- Children shall not play with the appliance.
- Cleaning and user maintenance shall not be made by children without supervision.
- Do not block the air inlet and outlet, e.g. by placing items on the air outlet or in front of the air inlet.
- Make sure that foreign objects do not fall into the appliance through the air outlet.
- Please avoid reaching your fingers or pet's tail inside the gap of scraper, pet hair container or air inlet.
- Do not touch or shake the purifier when the automatic floating hair collection system is working.

- Please make sure the pet hair container is installed in the right position before turning on the purifier.
- Do not reach your fingers inside the pet hair container to protect yourself from getting stuck or hurt.

### Caution

- This appliance is not a substitute for proper ventilation, regular vacuum cleaning, or use of an extractor hood or fan while cooking.
- Always place and use the appliance on a dry, stable, level, and horizontal surface.
- Leave at least 30cm free space around the appliance and leave at least 30cm free space above the appliance.
- Do not sit or stand on the appliance. Do not place anything on top of the appliance.
- Do not place the appliance directly below an air conditioner to prevent condensation from dripping onto the appliance.
- Make sure that all the filters are correctly installed before turning the appliance on.
- Only use the original Philips filters specially intended for this appliance. Do not use any other filters.
- Combustion of the filter may cause irreversible human hazard and/or jeopardize other lives. Do not use the filter as fuel or for similar purpose.
- Avoid knocking against the appliance (the air inlet and outlet in particular) with hard objects.
- Do not insert your fingers or objects into the air outlet or the air inlet to prevent physical injury or malfunctioning of the appliance.
- Do not use this appliance when you have used indoor smoke-type insect repellents or in places with oily residues, burning incense, or chemical fumes.
- Do not use the appliance near gas appliances, heating devices or fireplaces. Always unplug the appliance when you want to move, clean appliance, replace the filter or carry out maintenance.

- The appliance is only intended for household use under normal operating conditions.
- Do not use the appliance in wet surroundings or in surroundings with high ambient temperatures, such as the bathroom, toilet, or kitchen.
- The appliance does not remove carbon monoxide (CO) or radon (Rn). It cannot be used as a safety device in case of accidents with combustion processes and hazardous chemicals.

---

## Electromagnetic fields (EMF)

This appliance complies with the applicable standards and regulations regarding exposure to electromagnetic fields.

---

## Recycling

Do not throw away the product with the normal household waste at the end of its life, but hand it in at an official collection point for recycling. By doing this, you help to preserve the environment.

Follow your country's rules for the separate collection of electrical and electronic products. Correct disposal helps prevent negative consequences for the environment and human health.

## 2 Your pet air purifier

Congratulations on your purchase, and welcome to Philips!

To fully benefit from the support that Philips offers, register your product at [www.philips.com/welcome](http://www.philips.com/welcome).

### Product overview

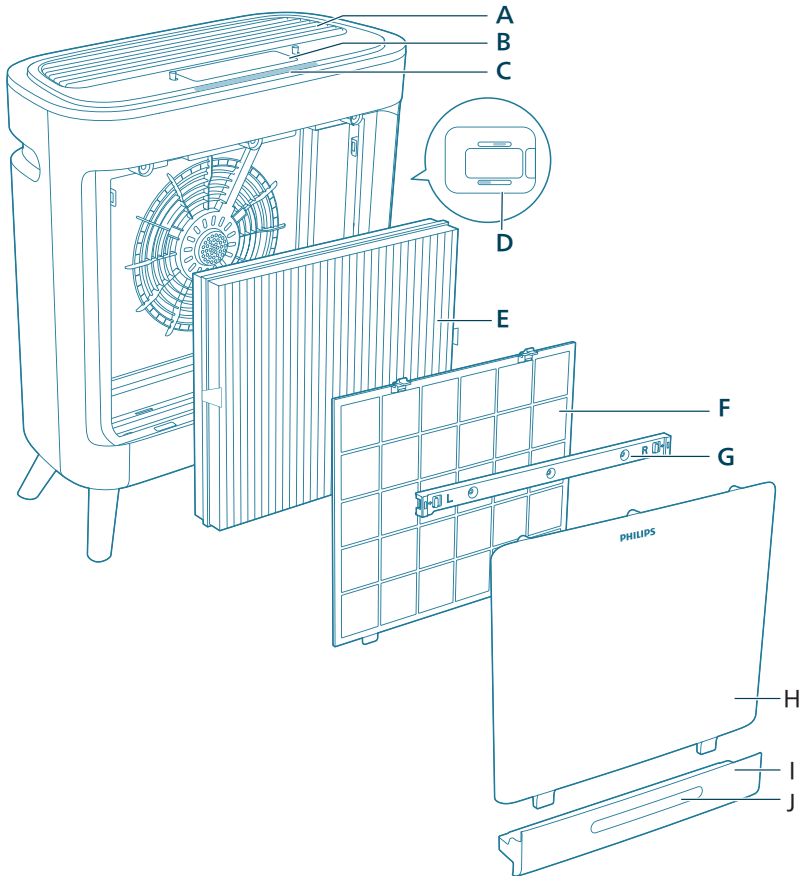





<b>A</b>	Air outlet	<b>F</b>	Pre-filter
<b>B</b>	Control panel	<b>G</b>	Floating hair scraper
<b>C</b>	Light stripe	<b>H</b>	Front cover
<b>D</b>	Air quality sensor	<b>I</b>	Pet hair container
<b>E</b>	Pet filter (FY3129)	<b>J</b>	Observation window









# Controls overview



## Control buttons

	Power on/off		Mode switch button/Filter reset button (long press 3 seconds)
	Automatic floating hair collection button		Fan speed switch button
	Pet lock		

## Display panel

	Filter replacement alert	<b>IAI</b>	Indoor Allergen index
<b>Gas</b>	Gas index		Pet lock indicator
	Auto mode		Sleep mode (lowest speed, all lights off)
	Pet turbo mode (highest speed)		Speed 1 (lower speed)
	Speed 2 (moderate speed)		Speed 3 (higher speed)

### Note:

- The display screen will automatically turn off after 30 seconds, touch any button to wake up the screen.
- When there is a change in the IAI and Gas index, the screen will automatically turn on and remain on until the reading becomes stable. Afterwards, the screen will turn off again after 30 seconds.

# 3 Getting started

## Installing the filter

Remove all packaging of the filter before first use.

**Note:** Make sure the air purifier is unplugged from the electrical outlet before installing the filter.

- 1 Open the front cover.

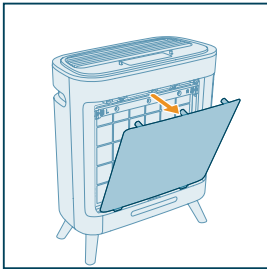

- 2 Push the buckle on both sides of the floating hair scraper and then pull the hair scraper outward to remove it.

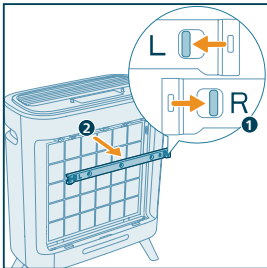

- 3 Press the clips located on the top of the pre-filter and gently pull it out from the appliance.

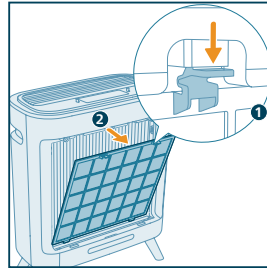

- 4 Remove the purification filter from the appliance by pulling out the white clips on both sides.

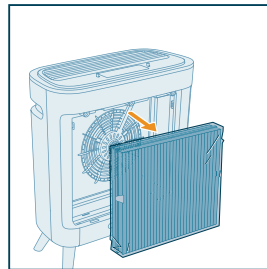

- 5 Remove all packaging materials of the purification filter.

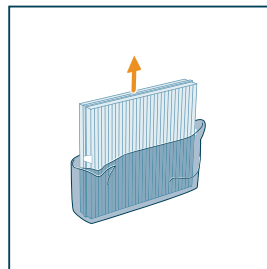



- 6 Put the pet filter back to the appliance, ensuring that the filter with two clips is facing outwards.

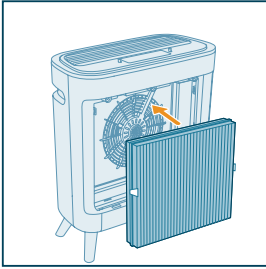

- 7 Put the pre-filter back to the appliance. Make sure you insert the pre-filter into the left and right holes at the bottom side. The two clips on the top of the filter make a "click" sound when installed properly.

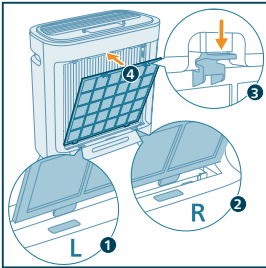

- 8 Install the floating hair scraper properly.

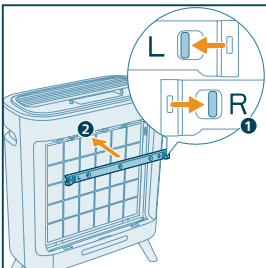

- 9 Reattach the front cover.

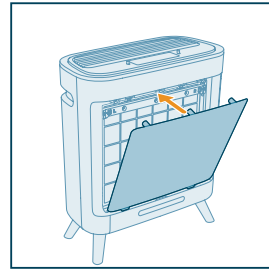

# 4 Using the air purifier

## Understanding the air quality light

The light strip automatically goes on when the pet air purifier is switched on.

After approximately 30 seconds, the screen displays the IAI and Gas readings.

### IAI

The professional-grade **AeraSense** sensor detects the level of indoor air allergen and with numerical feedback from 1 to 12 the potential risk level of indoor air allergens can be displayed. 1 indicates best air quality. Common allergens include airborne bacteria, tiny mold spores, pet allergens, and dust mite allergen particles.

IAI level	Air quality level
1-3	Good
4-6	Fair
7-9	Poor
10-12	Very poor

### Gas

With an advanced gas sensor, a display ranging from L1 to L4 shows the level change of potential harmful gases (incl. VOC, odor, etc.) detected. L1 indicates best air quality.

Gas level	Air quality level
L1	Good
L2	Fair
L3	Poor
L4	Very poor

## Turning on and off

### Note:

- For optimum purification performance, close doors and windows.
  - Avoid foreign objects (such as curtains) from falling into or obstructing the air inlet or air outlet.
- 1 Put the plug of the pet air purifier in the power socket.

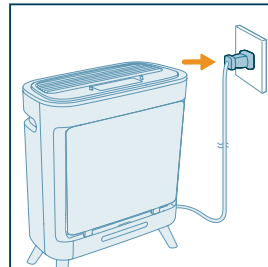

- 2 Push the power on/off toggle switch (⏻) downwards to turn on the purifier.
  - ↳ The purifier beeps. The white light stripe goes on.
  - ↳ The screen displays the IAI and Gas readings.

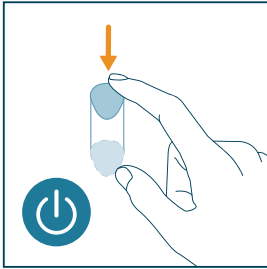

- 3 Push the power on/off toggle switch (⏻) downwards again to turn off the purifier.

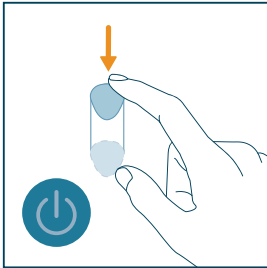

**Note:** If the air purifier stays connected to the electrical outlet after turning OFF, the air purifier will operate under the previous settings when turned ON again.

## Changing the mode setting

You can press the  button to select the Auto mode (A), the sleep mode (☾), or the pet turbo mode (🐾).

- **Auto mode:** The appliance automatically adjusts the fan speed in accordance with the ambient air quality.

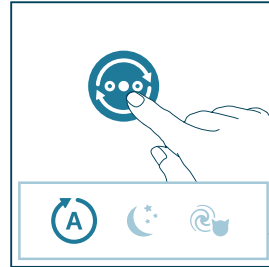

- **Sleep mode:** The appliance operates quietly at a low speed. After 3 seconds, the screen lights off.

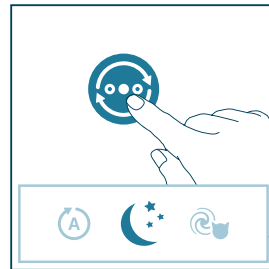

- **Pet turbo mode:** The appliance operates on the highest speed.

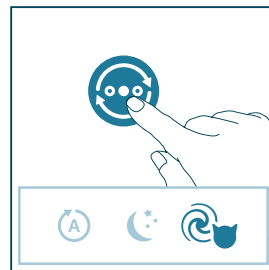

## Setting the pet lock

- 1 Push the pet lock toggle switch (🔒) downwards to activate the pet lock.
  - ↳ The 🔒 icon displays on the screen.
  - ↳ Other buttons are unresponsive.

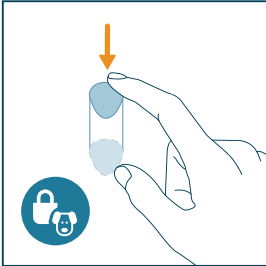

- 2 Push the pet lock toggle switch (🔒) downwards again to deactivate the pet lock.
  - ↳ The 🔒 icon disappears from the screen.

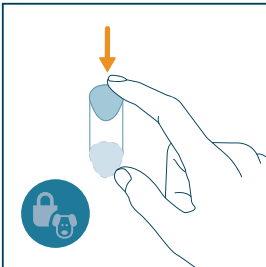

## Automatic floating hair cleaning

### Recommended frequency

Numbers of pets	Cleaning frequency
1 pet	Once every 1-2 weeks
2-3 pets	Once a week
>3 pets	Twice a week or more

There is an automatic floating hair cleaning count-down inside the purifier, when the plug is on the automatic count-down cleaning will be start at 360 hours after each floating hair cleaning. The automatic count-down cleaning will not operate if it's in sleep mode or dark environment is detected.

- 1 Press  the button to start the automatic floating hair collection system.
  - ↳ The light stripe on the top of the purifier blinks slowly.

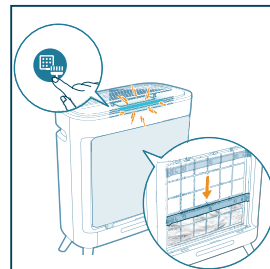

- 2 Pull out the pet hair container in a parallel direction.

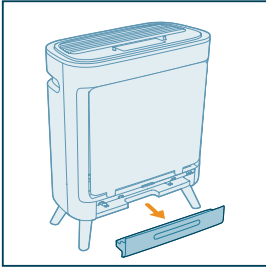

- 3 Transfer pet hair into the trash bin.

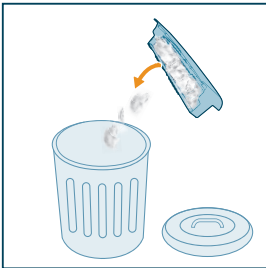

- 4 Put the pet hair container back to the appliance.

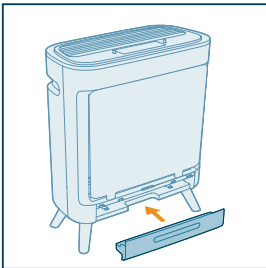

**Note:**

- The automatic floating hair collection system pauses when the front cover is opened. It resumes operation as soon as the front cover is securely closed.
- During the cleaning process, the fan speed will be automatically turned down and the mode cannot be changed until the cleaning process is finished.
- After the cleaning process is finished, the hair scraper resets to its origin position, and the white light stripe transitions from a blinking status to a steady, always on status.
- During the cleaning process, if the appliance is shut down or experiences a power outage, the cleaning process will be canceled. The hair scraper will reset automatically upon the next power-on.
- Please take out the pet hair container in a parallel direction. You can clean the container with clean cloth after pour out the waste. Please make sure the container is dry if you use wet cloth or water to clean it.
- We recommend people who are respiratory sensitive, not to clean the pet hair container by themselves or to take protective measures, such as mask and gloves.
- There is an automatic floating hair cleaning count-down inside the purifier, when the plug is on the automatic count-down cleaning will be start at 360 hours after each floating hair cleaning. The automatic count-down cleaning will not operate if it's in sleep mode or dark environment is detected.

# 5 Cleaning and maintenance

**Note:**

- Always unplug the appliance before you clean it.
- Never immerse the appliance in water or any other liquid.
- Never use abrasive, aggressive, or flammable cleaning agents such as bleach or alcohol to clean any part of the appliance.
- Never use any liquids (including water) to clean the pet filter.

## Cleaning the body of the air purifier

Regularly clean the inside and outside of the air purifier to prevent dust from collecting.

- Use a soft, dry cloth to clean both the interior and exterior of the air purifier and the air outlet.

## Cleaning the particle sensor

Clean the particle sensor every 2 months for optimal functioning of the appliance.

**Note:**

- If the air purifier is used in a dusty environment, it may need to be cleaned more often.
- If the humidity level in the room is very high, condensation may develop on the particle sensor and the air quality light may indicate a more poor air quality even though

the air quality is actually good. If this occurs, clean the particle sensor.

- 1 Switch off the air purifier and unplug from the power socket.

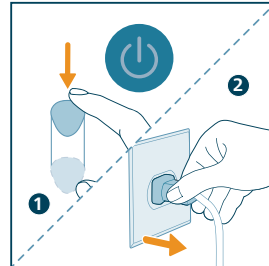

- 2 Open the air quality sensor cover.

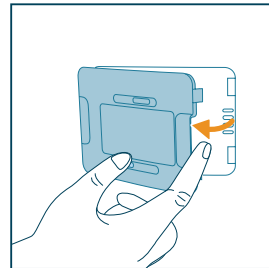

- 3 Clean the particle sensor with a damp cotton swab. Dry all parts thoroughly with a dry cotton swab.

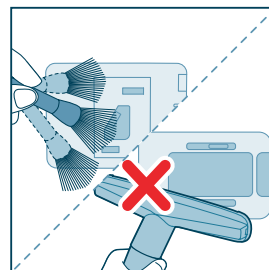

- 4 Close the air quality sensor.

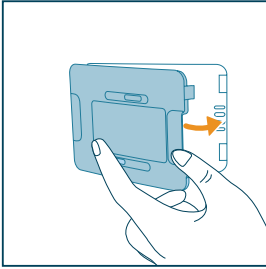

## Cleaning the filters

To ensure optimum performance, it is recommended to regularly clean both the pet filter and the pre-filter based on your current usage.

- 1 Switch off the appliance and unplug from the power socket

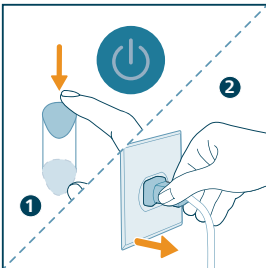

- 2 Use a cloth, or a vacuum cleaner to clean the pet filter and the pre-filter.

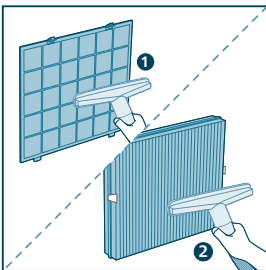

- 3 If the pre-filter is very dirty, use a soft brush to brush away the dust. Then wash the pre-filter under running tap water.

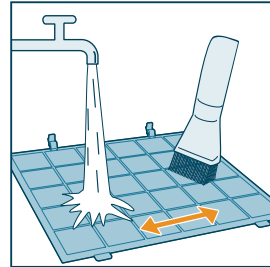

- 4 Allow the pre-filter to air dry thoroughly before placing back in the purifier.
- 5 Put the pre-filter back to the appliance. Make sure you insert the pre-filter into the left and right holes at the bottom side. The two clips on the top of the filter make a "click" sound when installed properly.

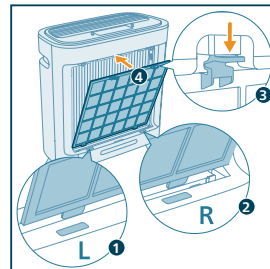

- 6 Wash your hands thoroughly after cleaning the filter.

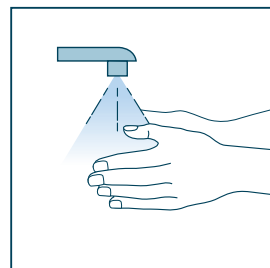

---

## Replacing the filter

---

### Understanding the healthy protection lock

This pet air purifier is equipped with a filter replacement indicator to make sure that the air purification filter is in optimal condition when the air purifier is operating. When the filter need to be replaced, the filter replacement alert  lights up red.

If the filter is not replaced in time, the air purifier will stop operating and automatically lock to protect the air quality in the room. Replace the filter as soon as possible.

---

### Replacing the pet filter

#### Note:

- The pet filter is not washable or reusable.
- Always turn off the purifier and unplug from the electrical outlet before replacing the pet filter.

When the filter replacement alert  lights up, replace the pet filter (FY3129).

- 1 Switch off the air purifier and unplug from the power socket.

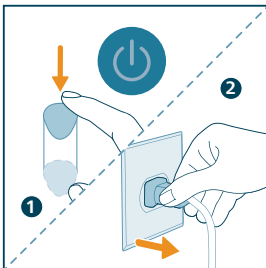

- 2 Open the front cover.

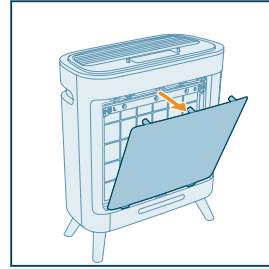

- 3 Push the buckle on both sides of the floating hair scraper and then pull the hair scraper outward to remove it.

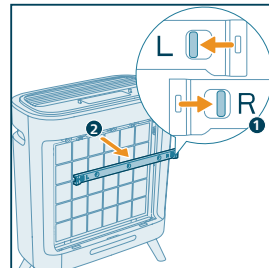

- 4 Press the clips located on the top of the pre-filter and gently pull it out from the appliance.

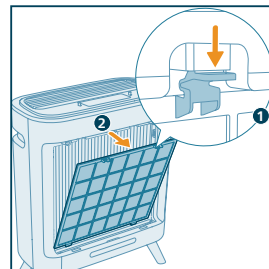



- 5 Remove the old pet filter from the appliance.

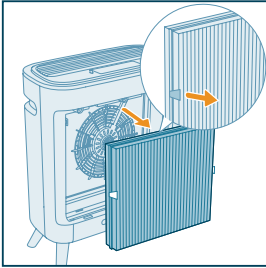

- 6 Remove all packaging materials of the new pet filter.

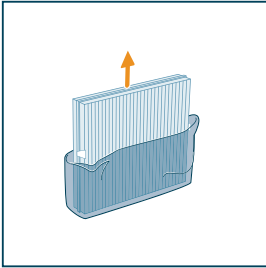

- 7 Put the new pet filter back to the appliance, ensuring that the filter with two clips is facing outwards.

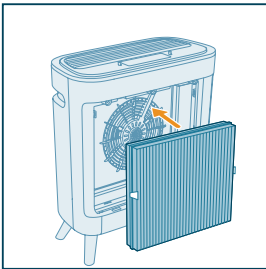

- 8 Put the pre-filter back to the appliance. Make sure you insert the pre-filter into the left and right holes at the bottom side. The two clips on the top of the filter make a "click" sound when installed properly.

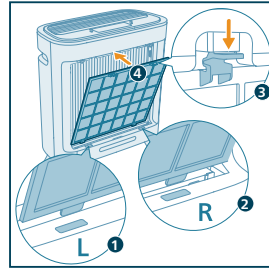

- 9 Install the floating hair scraper properly.

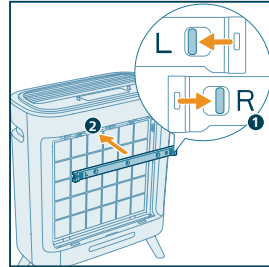

- 10 Reattach the front cover.

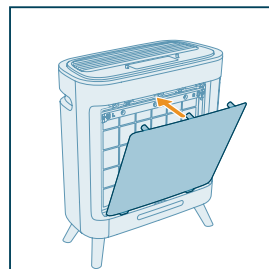

- 11** Put the plug of the appliance in the power socket.

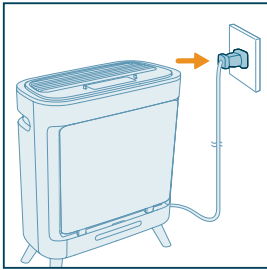

- 14** Wash your hands thoroughly after replacing the filter.

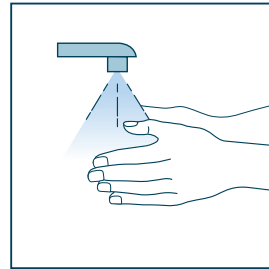

- 12** Push the power on/off toggle switch (  ) downwards to turn on the purifier.

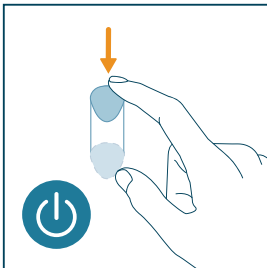

Note: Do not smell the filter as it has collected pollutants from the air.

- 13** Press and hold the  button for 3 seconds to reset the filter lifetime counter.

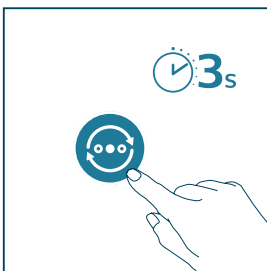

## Filter reset

You can replace the filter even before filter replacement alert (📄) displays on the screen. After replacing a filter, you need to reset the filter lifetime counter manually.

- 1 Push the power on/off toggle switch (⏻) downwards to turn off the purifier, and unplug the appliance.

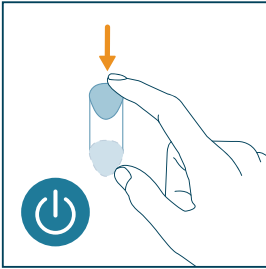

- 2 Make sure the appliance is completely unplugged, and then put the power plug in the power socket.

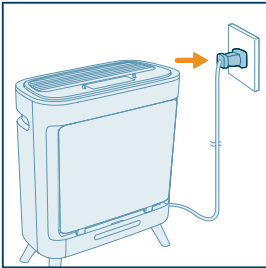

- 3 Within 15 seconds after power on, press and hold the ⌚ button for 3 seconds to reset the filter lifetime counter.

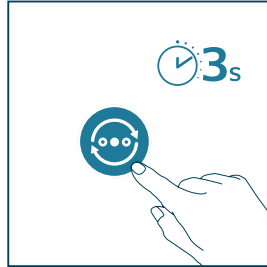

## 6 Storage



- 1 Turn off the air purifier and unplug from the power socket.
- 2 Clean the appliance, particle sensor and the surface of the filter (see chapter "Cleaning and maintenance").
- 3 Let all parts air dry thoroughly before storing.
- 4 Wrap the filters in air tight plastic bags.

- 5 Store the air purifier, filter in a cool, dry location.
- 6 Always thoroughly wash hands after handling the filter.

## 7 Troubleshooting

This chapter summarizes the most common problems you could encounter with the appliance. If you are unable to solve the problem with the information below, contact the Consumer Care Center in your country.

Problem	Possible solution
The appliance does not work properly.	<ul style="list-style-type: none"> <li>• Check if the front cover is properly installed. If not, for safety reason, the appliance will stop working.</li> <li>• The filter replacement alert is flashing but you have not replaced the corresponding filter. As a result, the appliance is now locked. In this case, replace the filter and reset the filter lifetime counter.</li> </ul>
The airflow that comes out of the air outlet is significantly weaker than before.	<ul style="list-style-type: none"> <li>• The surface of the filter is dirty. Clean the surface of the filter (see the chapter "Cleaning and maintenance").</li> </ul>
The air quality does not improve, even though the appliance has been operating for a long time.	<ul style="list-style-type: none"> <li>• Check if the packing material is removed from the filter.</li> <li>• Make sure that the filter (FY3129) is properly installed.</li> <li>• If you want to purify the Indoor pollution sources, switch to the pet turbo mode.</li> <li>• Room size is large or the outdoor air quality is poor. For optimum purification performance, please close the doors and windows when operating the air purifier.</li> <li>• For optimum purification performance, avoid to obstruct the appliance with objects in its vicinity.</li> <li>• For optimum purification performance, we strongly recommend following the instructions in the user manual to regularly clean or replace the filter.</li> </ul>

Problem	Possible solution
<p>The appliance produces a strange smell.</p>	<ul style="list-style-type: none"> <li>• The first few times you use the appliance, it may produce a plastic smell. This is normal. However, if the appliance produces a burnt smell even if removing filters, contact your Philips dealer or an authorized Philips service center. The filter may produce smell after being used for a while because of the absorption of indoor gases. It's recommended that you reactivate the filter by putting it in direct sunlight for repeated use. If odor still exists, replace the filter.</li> <li>• Neglecting to clean the pet hair container or pre-filter may result in the accumulation of hair or dust, which can lead to an unpleasant smell.</li> </ul>
<p>The appliance is extra loud.</p>	<ul style="list-style-type: none"> <li>• The appliance runs in pet turbo mode, it is normal.</li> <li>• In the Auto mode, if the appliance is too loud, maybe the appliance runs at high speed because air quality becomes worse. When using the appliance in a bedroom at night, choose the Sleep speed.</li> <li>• During the use of the automatic floating hair cleaning system, you may hear the sound of the scraper running. You have the flexibility to utilize this function at a suitable time or pause it whenever needed. Additionally, the system will not operate when in sleep mode, or in a dark environment.</li> <li>• If there is abnormal sound, contact the Consumer Care Center in your country.</li> <li>• If anything drops into air outlet, it may also cause abnormal loud sounds. Immediate turn off appliance, turn appliance upside down, to get foreign objectives out of appliance.</li> </ul>
<p>The appliance still indicates that I need to replace a filter, but I already did.</p>	<ul style="list-style-type: none"> <li>• Perhaps you did not reset the filter lifetime counter. Switch on the appliance. Then press and hold the  for 3 seconds until  disappears.</li> </ul>
<p>Error code "E1" displays on the screen.</p>	<ul style="list-style-type: none"> <li>• The motor has malfunctions. Improper installation can cause the temporary malfunctions. Please unplug the appliance and ensure the pre-filter is properly installed (see the chapter "Installing the filter"). If issue persists, please contact the Consume Care Center in your country.</li> </ul>

## 8 Warranty and support

Versuni offers a two-year warranty after purchase on this product. This warranty is not valid if a defect is due to incorrect use or poor maintenance. Our warranty does not affect your rights under law as a consumer. For more information or for invoking the warranty, please visit our website [www.philips.com/support](http://www.philips.com/support).

---

### Order parts or accessories

If you have to replace a part or want to purchase an additional part, go to your Philips dealer or visit [www.philips.com/support](http://www.philips.com/support).

If you have problems obtaining the parts, please contact the Philips Consumer Care Center in your country.





PHILIPS and the Philips Shield Emblem are registered trademarks of Koninklijke Philips N.V. and are used under license.

This product has been manufactured by and is sold under the responsibility of Versuni Holding B.V., and Versuni Holding B.V. is the warrantor in relation to this product.

2024 © Versuni Holding B.V.

AC3681\_HK\_UM\_v2.0 (25/04/2024)

