

Always there to help you
始终如一地为您提供帮助

HD2586
HD2587
HD2589

Register your product and get support at
请登录以下网址并得到相应的帮助
www.philips.com/welcome

Question?
有疑问?
Contact Philips
请联系飞利浦



EN	User manual	TH	คู่มือผู้ใช้
IN	Buku Petunjuk Pengguna	VI	Hướng dẫn sử dụng
KO	사용 설명서	ZH-CN	用户手册
MS-MY	Manual pengguna	ZH-HK	使用手冊

PHILIPS

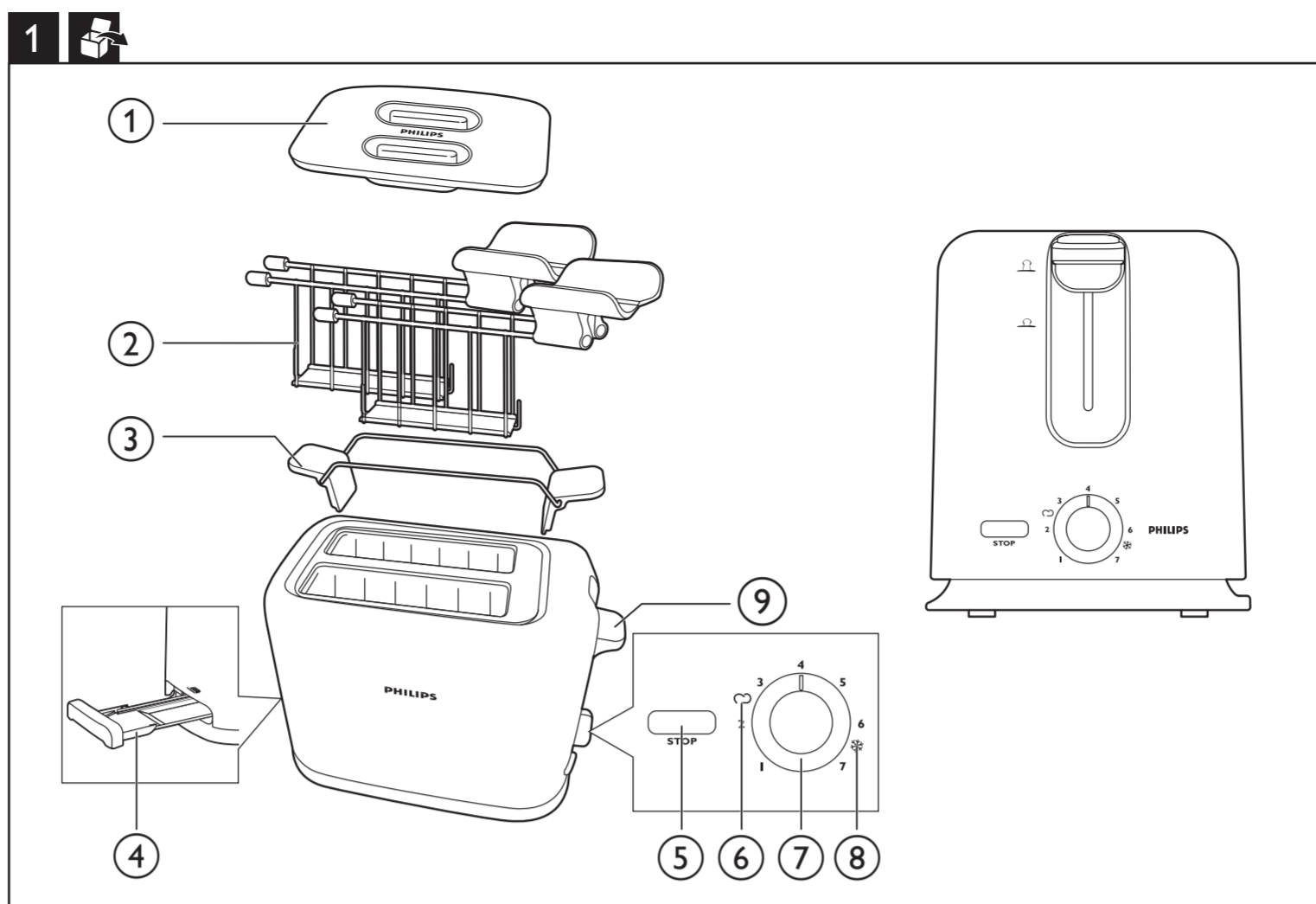

English

- 1 Dust cover (HD2586/HD2587 only)
- 2 Bread baskets with squeeze handle (HD2589 only)
- 3 Warming rack (HD2587 only)
- 4 Crumb tray
- 5 STOP button
- 6 Warming function (specific type only)
- 7 Browning control
- 8 Defrost function
- 9 Toasting lever

한국어

- 1 먼지 덮개 (HD2586/HD2587 모델만 해당)
- 2 스퀴즈 손잡이가 달린 빵 바구니 (HD2589 모델만 해당)
- 3 빵 데우기 받침대 (HD2587 모델만 해당)
- 4 빵 부스러기 받침대
- 5 중지 버튼
- 6 데우기 기능 (특정 모델만 해당)
- 7 굽기 조절
- 8 해동 기능
- 9 토스팅 레버

Indonesia

- 1 Pelindung debu (hanya HD2586/HD2587)
- 2 Keranjang roti dengan pegangan tekan (hanya HD2589)
- 3 Rak penghangat (HD2587 saja)
- 4 Baki serpihan
- 5 Tombol STOP
- 6 Fungsi penghangat (hanya tipe tertentu)
- 7 Kontrol kematangan
- 8 Fungsi pencair
- 9 Tuas pemanggang

Bahasa Melayu

- 1 Penutup debu (HD2586/HD2587 sahaja)
- 2 Bakul roti dengan pemegang tekan (HD2589 sahaja)
- 3 Rak pemanas (HD2587 sahaja)
- 4 Bekas serdak
- 5 Butang STOP
- 6 Fungsi pemanasan (jenis tertentu sahaja)
- 7 Alat kawalan pematangan
- 8 Fungsi nyahfros
- 9 Tuil pembakar

ภาษาไทย

- 1 ฝาครอบป้องกันฝุ่น (เฉพาะรุ่น HD2586/HD2587)
- 2 ตะแกรงขนมปังพร้อมที่จับบีบได้ (เฉพาะรุ่น HD2589)
- 3 ตะแกรงอุ่น (เฉพาะรุ่น HD2587)
- 4 ถาดรองเศษขนมปัง
- 5 ปุ่ม STOP (หยุด)
- 6 ฟังก์ชันอุ่นขนมปัง (เฉพาะบางรุ่นเท่านั้น)
- 7 ปุ่มควบคุมความเหลืองกรอบ
- 8 ฟังก์ชันละลายน้ำแข็ง
- 9 คันโยกสำหรับปิ้ง

Tiếng Việt

- 1 Nắp đậy (chỉ có ở kiểu HD2586/HD2587)
- 2 Giỏ đựng bánh mì có tay cầm bóp (chỉ có ở kiểu HD2589)
- 3 Vỉ hâm nóng (chỉ có ở kiểu HD2587)
- 4 Khay đựng mảnh vụn bánh mì
- 5 Nút STOP (Dừng)
- 6 Chức năng hâm nóng (chỉ có ở một vài kiểu cụ thể)
- 7 Điều khiển độ chín vàng
- 8 Chức năng rã đông
- 9 Cán nướng

简体中文

- 1 防尘罩 (仅限于 HD2586/HD2587)
- 2 面包烤篮 (具有挤压手柄) (仅限于 HD2589)
- 3 烘烤架 (仅限于 HD2587)
- 4 面包屑底盘
- 5 STOP 按钮
- 6 加热功能 (仅限于特定型号)
- 7 烘烤程度设置
- 8 解冻功能
- 9 烘烤杆

繁體中文

- 1 防塵蓋 (僅限 HD2586/HD2587)
- 2 備有擠壓手柄的 (僅限 HD2589)
- 3 溫熱架 (僅限 HD2587)
- 4 麵包屑載盤
- 5 停止按鈕
- 6 保溫功能 (僅限指定類型)
- 7 烘烤控制
- 8 解凍功能
- 9 烤麵包撥桿

技术规格如有变更，恕不另行通知
© 2014 Koninklijke Philips N.V.
保留所有权利



HD2586_HD2587_HD2589_ROW_UM_V2.0

3140 035 32812

