

map
Italian coffee

Caffitaly
system



BRAVISTA
Espresso
+

Crafted by

 **Saeco**

Saeco is a trademark of the Philips Group



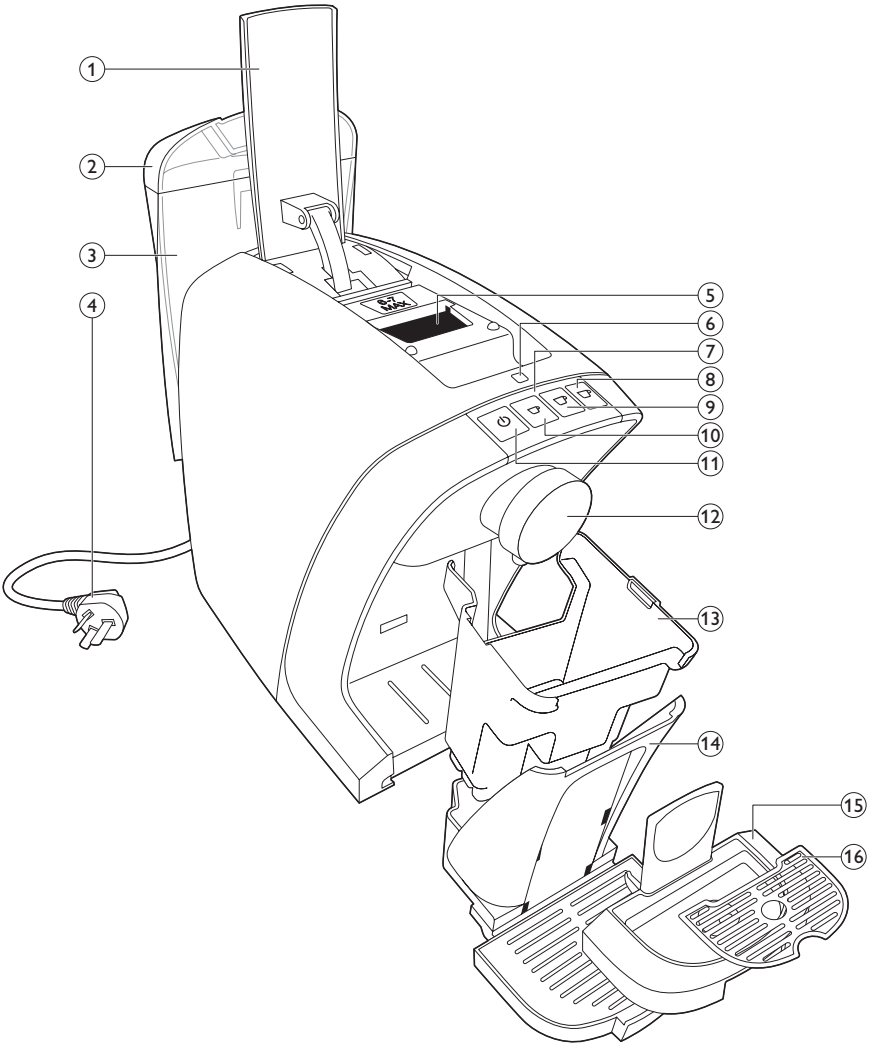

HD8602

ENGLISH 6

Table of contents

Introduction	6
General description	6
Important	7
Electromagnetic fields (EMF)	8
Before first use	8
Installing the machine	8
Preparing for use	9
Filling the water tank	9
Using the machine for the first time	9
Using the machine	10
Adjusting the drip tray height	10
Capsules	11
Brewing coffee	11
Adjusting the coffee quantity	13
Resetting the coffee quantities	13
Cleaning and maintenance	13
Cleaning the used capsule drawer and waste water drawer	14
Daily cleaning of the water tank	15
Weekly cleaning of the coffee circuit (priming)	15
Descaling the machine	16
Descaling procedure	16
Meaning of light signals	18
Accessories	19
Environment	19
Troubleshooting	19
Warranty	21

Introduction

Congratulations on buying the Bravista Espresso coffee capsule machine! This user manual applies to HD8602. The machine is suitable for preparing espresso, lungo and black coffee using the Caffitaly branded capsules. The machine can be used with a variety of cup sizes to dispense your different coffee varieties. In this user manual you find all the information you need to install, use and maintain your machine.

General description (Fig. 1)

- 1 Capsule compartment opening lever
- 2 Water tank lid
- 3 Water tank
- 4 Mains cord
- 5 Capsule compartment
- 6 Service indicator light (orange)
- 7 Control panel
- 8 Black coffee button (blue)
- 9 Lungo button (yellow)
- 10 Espresso button (white)
- 11 On/off button (green)
- 12 Coffee dispensing spout
- 13 Used capsule drawer
- 14 Waste water drawer
- 15 Adjustable and removable drip tray
- 16 Cup tray

Important

Read and follow the safety instructions carefully and only use the machine as described in this user manual to avoid accidental injury or damage due to improper use of the machine. Keep this user manual for future reference.

Danger

- Never immerse the machine in water or any other liquid.

Warning

- Check if the voltage indicated on the machine corresponds to the local mains voltage before you connect the machine.
- Connect the machine to an earthed wall socket.
- This machine can be used by children aged from 8 years and above and by persons with reduced physical, sensory or mental capabilities or lack of experience and knowledge if they have been given supervision or instruction concerning use of the appliance in a safe way and if they understand the hazards involved.
- Cleaning and maintenance shall not be made by children unless they are older than 8 and supervised.
- Children should be supervised to ensure that they do not play with the machine.
- Keep the machine and its cord out of the reach of children aged less than 8 years.
- Do not pour liquids on the mains cord connector.
- Do not use the machine if the plug, the mains cord or the machine itself is damaged.
- Do not touch hot surfaces. The surface of the heating element is subject to residual heat after use.
- Do not lift the machine by the lever that opens the capsule compartment. To move the machine, hold it by the outer housing.
- Never let the machine operate unattended.
- The machine is equipped with non-slip feet. Work surfaces often have varnished or plastic finishes and are treated with a variety of substances. Some of these products may contain substances that react adversely with the rubber feet and soften them.
- Remove the plug from the wall socket if the machine malfunctions, if you are not going to use the machine for a long time and before you clean the machine.
- Pull at the plug, not at the mains cord. Do not touch the plug with wet hands.
- If the mains cord is damaged, you must have it replaced by Saeco, a service centre authorised by Saeco or similarly qualified persons in order to avoid a hazard.
- Always return the machine to a service centre authorised by Saeco for examination or repair. Do not attempt to repair the machine yourself, otherwise your guarantee becomes invalid.
- Never insert your fingers into the capsule compartment.

Caution

- Always put the machine on a flat and stable surface. Keep it in an upright position (also during transport).
- Do not place the machine on a hotplate or directly next to a hot oven, heater or similar source of heat.
- Only use the original Caffitaly branded capsules. Neither use capsules from other manufactures, nor damaged or misshapen capsules, and never fill capsules or the machine with ground coffee or instant coffee, as this will damage the machine. In these cases, any necessary repairs due to damage are not covered by the guarantee.
- Descale the machine regularly.
- If you do not clean and descale the machine, you run the risk that the machine stops working and that your guarantee becomes invalid.
- Never fill the water tank with warm, hot or sparkling water; as this may cause damage to the water tank and the machine.
- Do not use aggressive cleaning agents, solvents or chemicals to clean the machine.
- Do not keep the machine at temperatures below 0°C. Water left in the heating system may freeze and cause damage.
- This machine is intended for normal household use only. It is not intended for use in environments such as staff kitchens, shops, offices, farms or other work environments. Nor is it intended to be used by clients in hotels, motels, bed and breakfasts and other residential environments.
- Always use fresh water when you use the machine. Empty the water tank if you are not going to use the machine for a long time.
- Always make sure that the drip tray and the used capsule drawer are inserted when you use the machine.

Electromagnetic fields (EMF)

This machine complies with all applicable standards and regulations regarding exposure to electromagnetic fields.

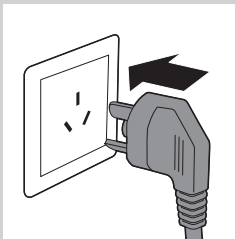
Before first use**Installing the machine**

- 1** Remove all packaging material from the machine.
- 2** Place the machine on a table or worktop away from the tap, the sink and heat sources.
- 3** Put the plug in the wall socket.

Preparing for use

Filling the water tank

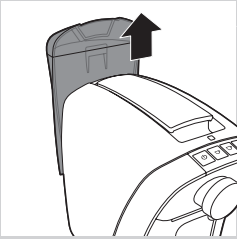

- 1 Remove the water tank from the machine.

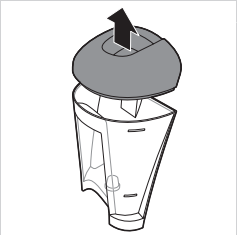

- 2 Remove the lid from the water tank. Rinse the water tank under the tap.



- 3 Fill the water tank with cold tap water up to the MAX indication.
- 4 Place the lid back onto the water tank.
- 5 Place the water tank back onto the machine.

Using the machine for the first time

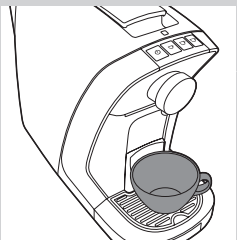

When you use the machine for the first time or if you have not used it for 2 weeks or longer, perform the following steps:

- 1 Place a cup under the coffee dispensing spout. Do not insert a capsule, but make sure that the lever is closed.

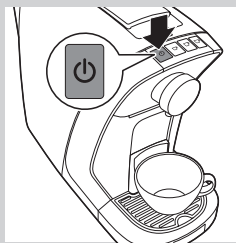

2 Press the on/off button (green).

► The on/off button flashes green slowly to indicate the machine is heating up. When the on/off button lights up green continuously, it is ready to perform the next step.

► The orange service indicator light flashes to indicate that no water has been pumped into the system yet.

3 Press the yellow lungo button. Water flows from the coffee dispensing spout.

Note: The machine stops brewing automatically once it has dispensed the preset coffee cup volume.

Note: If the cup is full before the machine stops dispensing, you can stop the brewing process by pressing the yellow lungo button again.

Note: When the internal circuit is empty, the machine produces a humming sound. When the machine dispenses water, it produces less loud humming sounds. This is normal.

4 Empty the cup and place it back under the coffee dispensing spout.

5 Repeat steps 3-5 until the water tank is empty.

Note: The orange service indicator light flashes to indicate that the water tank is empty.

6 Fill the water tank up to the MAX indication.

Note: The orange service indicator light stops flashing when you brew another beverage.

7 Empty the drip tray and waste water drawer. See chapter 'Cleaning and maintenance', section 'Cleaning the used capsule drawer and waste water drawer'.

The machine is now ready for use.

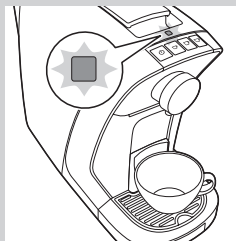

Using the machine

Adjusting the drip tray height

The machine can be used with a range of cup sizes. You can position the drip tray at two different heights or even remove to suit the size of your cup and the coffee variety you want to brew.

Note: When you use an espresso cup, put the drip tray in the highest position.

1 To remove the drip tray, grab it on both sides, tilt it upwards slightly and lift it off the machine.

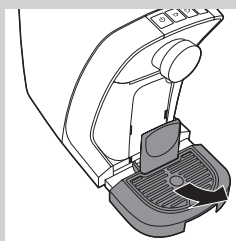

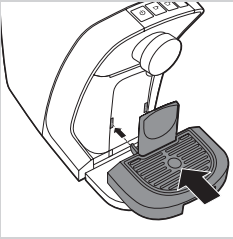

- 2** To attach the drip tray, insert the pins into the appropriate height slots and push the drip tray slightly inwards and downwards.

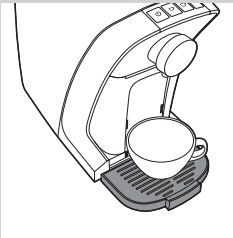

- 3** To obtain the greatest brewing height to suit very large cups, remove the drip tray and place the cup directly on the base of the machine.

Capsules

Only Caffitaly branded capsules are compatible with the Caffitaly system. Any other capsules will damage the machine and void the manufacturer warranty.

Brewing coffee



- 1** Press the on/off button (green). The on/off button flashes green to indicate the machine is heating up.
- 2** Choose a cup that suits the type of coffee you want to brew. If necessary, adjust the position of the drip tray. Place the cup under the dispensing spout.

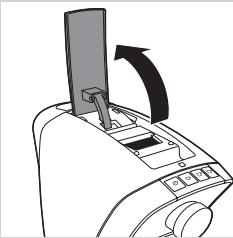

- 3** Lift the capsule compartment opening lever.

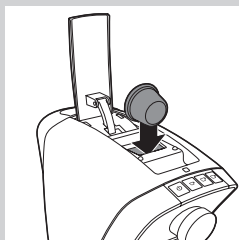

4 Insert a capsule.



5 Push the lever downwards to close the capsule compartment.

Note: If the compartment opening lever does not close easily, check if the capsule is inserted correctly and if the used capsule drawer is not full.

6 Press the desired coffee button:

- ▶ Espresso: press the white button
- ▶ Lungo: press the yellow button
- ▶ Black coffee: press the blue button

Note: For an optimal taste of black coffee, rinse the internal circuit before and after you brew a black coffee. See chapter 'Cleaning and maintenance', section 'Weekly cleaning of the coffee circuit (priming)'.

7 The machine stops brewing automatically once it has dispensed the preset coffee volume. To stop the brewing process, you can press the same coffee button once more.

Note: The machine brews at a certain speed and produces humming sounds during brewing. These speeds and sounds differ for the different coffee varieties. This is normal.

8 Lift the lever to remove the used capsule.

Note: The machine switches off automatically after 9 minutes of inactivity. Press the on/off button to switch the machine back on.

Note: After every coffee that the machine brews, a small amount of water flows into the waste water drawer. Empty the waste water drawer regularly.

Note: If the machine stops earlier during the brewing process and the service indicator light flashes slowly, the internal circuit of the machine is empty. Fill the water tank with water, do not insert a new capsule and press the button of selected coffee variety again to continue brewing. When the cup contains the desired amount of coffee, press the same button again to stop the brewing process.

Never insert your fingers or any other objects into the capsule compartment. Single-dose capsules brew a single coffee. Do not use capsules more than once. When you prepare an espresso or lungo, the machine performs a pre- brewing cycle. There is an audible pause in the brewing process between the pre-brewing and brewing cycles.

Adjusting the coffee quantity

Each capsule contains the optimal amount of ground coffee (8 grams) for one cup of espresso or lungo with an optimal flavour. You can adjust the amount of brewed coffee according to your taste and the size of your cup, mug or glass.

Each coffee variety button brews a preset amount of coffee.

▶ Espresso: approx. 40ml

▶ Lungo: approx. 125ml

▶ Black coffee: approx. 125ml

Note: This quantity can be reprogrammed according to your taste for each type of coffee. The minimum quantity that can be set is approximately 30ml and the maximum quantity that can be set is approximately 300ml.

For optimal extraction for an espresso capsule, a maximum pour length of 60 ml is recommended.

To program the quantity of espresso, lungo or black coffee:

- 1** Choose a cup that suits the type of coffee you want to brew. If necessary, adjust the position of the drip tray.
- 2** Place the cup under the coffee dispensing spout.
- 3** Insert a capsule and push the lever downwards to close the capsule compartment.
- 4** Press and hold the button of the desired coffee variety for 3 seconds until it starts to flash at brief intervals. Then release the button. The machine starts brewing coffee.
- 5** Press the same button again when the cup contains the desired amount of coffee.

Note: The selected coffee button has now been reprogrammed. The machine will dispense the reprogrammed amount of coffee every time you press this button.

Resetting the coffee quantities

To reset the coffee quantities to their factory settings:

- 1** Switch off the machine.
 - 2** Press and hold the on/off button (green) and the blue black coffee button for 5 seconds.
- ▶ All buttons flash twice.

Cleaning and maintenance

Regular cleaning and descaling prolongs the lifetime of your machine and ensures optimum quality and taste of your coffee.

Do not immerse the machine in water or any other liquid.

Never use scouring pads, abrasive cleaning agents or aggressive liquids to clean the machine.

Always unplug the machine and let it cool down before you clean it.

Use a soft, damp cloth to clean the machine.

Cleaning the used capsule drawer and waste water drawer

Clean the used capsule and waste water drawer after each 6-7 cups of coffee that the machine has brewed.

Check periodically if the used capsule drawer and waste water drawer are not full, to avoid damage and malfunctioning of the machine.

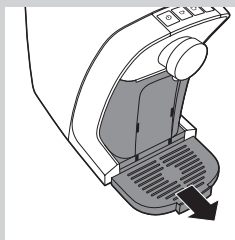

1 To remove the drip tray, grab it on both sides, tilt it upwards slightly and lift it off the machine.

2 Pull the used capsule drawer and the waste water drawer out of the machine.

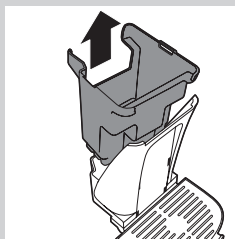

3 Take out the used capsule drawer by moving it backwards from the waste water drawer and pulling it up.

4 Empty the used capsule drawer.

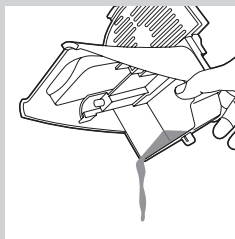

5 Empty the waste water drawer.

6 Empty the drip tray.

7 Rinse all parts under a warm tap. Dry all parts with a soft cloth.

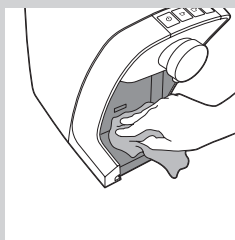

8 Wipe the inner compartment with a damp cloth and then with a dry cloth.

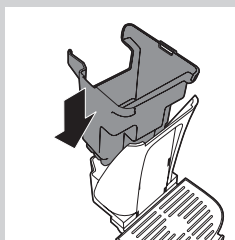

9 Reinsert the used capsule drawer into the waste water drawer.

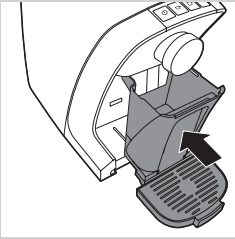

- 10** Insert the used capsule drawer into the machine until it clicks into position.

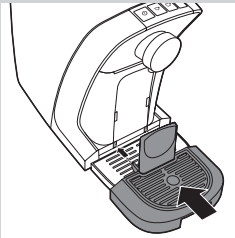

- 11** Place the drip tray back onto the machine.

Daily cleaning of the water tank

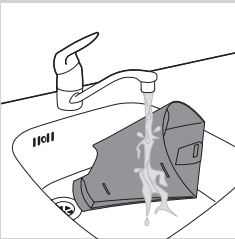

- Rinse the water tank under the tap every day. This prevents scale and other particles from clogging the filter at the bottom of the water tank.

Weekly cleaning of the coffee circuit (priming)

Clean the coffee circuit every week to ensure an optimum quality and taste of your coffee.

- 1** Place a cup under the coffee dispensing spout. See chapter 'Using the machine', section 'Adjusting the drip tray height'.
- 2** Lift the lever to open the capsule compartment. By opening the capsule compartment, the used capsule will be removed automatically, do not insert a new capsule.
- 3** Close the lever.
- 4** Press the yellow lungo button.
- 5** Empty the cup after the machine has finished dispensing water. The machine is now ready for use.

Descaling the machine

Scale builds up inside the machine during use. It is essential to descale the machine when the service indicator light illuminates continuously.

Only use the Saeco descaling solution to descale the machine. The Saeco descaling solution is designed to ensure optimal performance of the machine. You can buy the Saeco descaling solution (CA6700) online at www.mapcoffee.com.

Note: The use of other descaling products may cause damage to the machine and leave residues in the water.

Never drink the water with descaling mixture that you pour into the water tank or any water with residues that comes out of the machine during the descaling procedure.

Descaling procedure

The descaling procedure lasts 30 minutes and consists of a descaling and a rinsing cycle.

Note: Do not interrupt the descaling or rinsing cycle and do not switch off the machine. During the descaling cycle, the descaling solution will be dispensed from the coffee dispensing spout in intervals. During the rinsing cycle with fresh water, water flows out of the coffee dispensing spout.

- 1** Switch off the machine.
- 2** Make sure that there is no capsule in the capsule compartment and the capsule compartment opening lever is in closed position.
- 3** Remove and empty the water tank, drip tray, waste water drawer and used capsule drawer.
- 4** Pour the entire bottle of Saeco descaling solution (250ml) into the water tank.
- 5** Add water to the descaling solution in the water tank up to the MAX indication.
- 6** Insert the waste water drawer and used capsule drawer into the machine.

Note: Do not place the drip tray and metal cup tray into the machine.

- 7** Place a bowl with a minimum capacity of 1 litre under the coffee dispensing spout to collect the descaling solution.
- 8** Press the espresso button (white) and the lungo button (yellow) simultaneously for approximately 3 seconds until the orange service indicator light lights up.

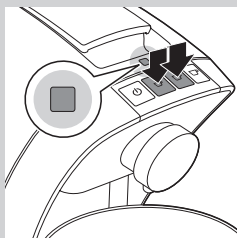

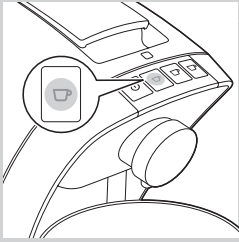

- 9** The espresso button lights up white continuously to indicate that the descaling mode is activated.

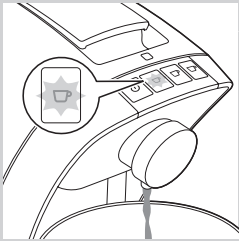

- 10** Press the espresso button (white) to start the descaling cycle.
 ▶ The machine dispenses the entire descaling solution at regular intervals through the coffee dispensing spout. The espresso button flashes white during the entire descaling cycle.

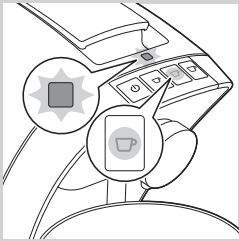

- 11** When the machine has dispensed all the descaling solution, the orange service indicator light flashes and the lungo button lights up yellow continuously.

- 12** Remove and empty the bowl and waste water drawer. Reinsert the waste water drawer and put the bowl back under the coffee dispensing spout.

- 13** Remove the water tank and rinse it under the tap. Fill the water tank with fresh tap water up to the MAX indication and place the water tank back onto the machine.

- 14** Press lungo button (yellow) to start the rinsing cycle.
 ▶ Water flows out of the coffee dispensing spout. The lungo button flashes yellow during the entire rinsing cycle.

- 15** When the rinsing cycle has finished, all buttons flash a few times and the machine switches off.

- 16** Remove the bowl and empty the water tank and waste water drawer.

- 17** Clean and dry the cup tray carefully. Fill the water tank with fresh tap water up to the MAX indication and place the water tank, drip tray and cup tray back onto the machine.

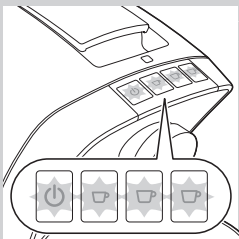

Note: If after the rinsing cycle the orange service indicator light continues to flash and the yellow lungo button lights up continuously, repeat steps 13-17 once more and make sure the water tank is filled up to the MAX indication.

Note: If you switch off the machine during the descaling or rinsing cycle by unplugging the mains cord, you need to finish the descaling procedure before you can brew coffee. Plug the mains cord back in. Press the on/off button (green) to switch on the machine. If the espresso button lights up white continuously, continue the descaling cycle by pressing the white espresso button and follow steps 10-17. When the yellow lungo button lights up continuously, continue the rinsing cycle by pressing on the yellow lungo button and follow steps 13-17.

The machine is now ready for use.

Note: The next time you switch on the machine after the descaling cycle, the orange service indicator light flashes to indicate the water tank is empty. Fill the water tank up to the MAX indication, insert a capsule, close the lever and press the desired coffee variety button. The orange service indicator light stops flashing and the machine will dispense the coffee.

Meaning of light signals

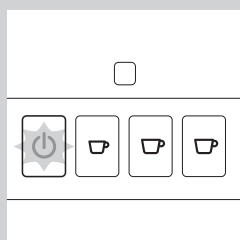

- The on/off button (green) flashes slowly. The machine is warming up.

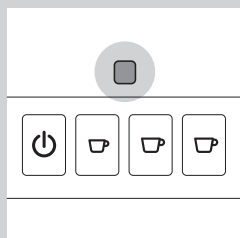

- The orange service indicator light lights up continuously. You have to descale the machine. Follow the instructions in chapter 'Descaling the machine'.

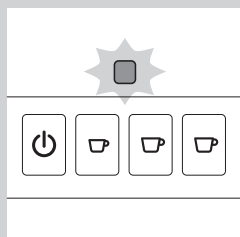

- The orange service indicator light flashes slowly. Fill the water tank with fresh water up to the MAX indication, make sure there is no capsule in the machine. Press the yellow lungo button. The internal water circuit is now filled with water and the service indicator light goes out.

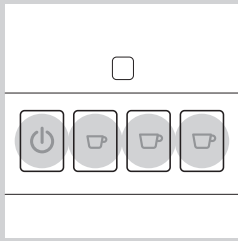

- All lights light up continuously. The machine is ready for use.

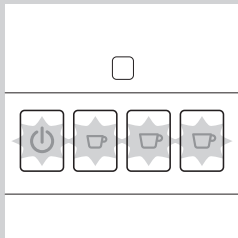

- All lights flash simultaneously. Contact our Consumer Care Centre on 1300 363 391 in Australia or 0800 658 224 in New Zealand.

Accessories

To purchase accessories for this machine please visit **www.mapcoffee.com**. If you are having difficulties to obtain accessories for your machine, please contact our Consumer Care Centre on 0800 726 713 in New Zealand.

Environment

Do not throw away the product with the normal household waste at the end of its life, but hand it in at an official collection point for recycling. By doing this, you help to preserve the environment.

Troubleshooting

This chapter summarises the most common problems you could encounter with the appliance. If you are unable to solve the problem with the information below contact our Consumer Care Centre on 0800 726 713 in New Zealand.

Problem	Possible cause	Solution
The machine does not switch on.	The machine is not connected to the mains.	Put the mains plug in an earthed wall socket. Contact the Consumer Care Centre.
The machine needs a long time to warm up.	The machine is clogged with scale.	Descale the machine (see chapter 'Descaling the machine')
The pump makes a lot of noise.	There is not enough water in the water tank.	Fill the water tank with fresh tap water up to the MAX indication.
	Water tank is not placed correctly.	Place the water tank correctly and push it downwards.
I cannot close the capsule compartment lever completely.	The used capsule drawer is full.	Empty the used capsule drawer and insert the capsule again.
	The capsule is not inserted correctly.	Insert the capsule again and check if it is inserted correctly.
	The capsule is stuck.	Open and close the lever a few times with moderate force to remove the capsule.
The lever does not open completely.	The used capsule drawer is full.	Empty the used capsule drawer.
The machine does not dispense coffee or only dispenses drops of coffee.	There is not enough water in the water tank.	Fill the water tank with fresh tap water up to the MAX indication.
	Scale has built up inside the machine.	Descale the machine (see chapter 'Descaling the machine').
The machine suddenly stops brewing coffee.	There is not enough water in the water tank.	Fill the water tank with fresh tap water up to the MAX indication. Press the button of selected coffee variety again to continue brewing. When the cup is full, press the same button again to stop the brewing process.
Coffee grounds end up in the cup of coffee.	A small amount of ground coffee will always end up on the bottom of the cup.	This is normal.
The service indicator light lights up continuously.	The machine is clogged with scale.	Descale the machine (see chapter 'Descaling the machine')
The service indicator light flashes slowly.	The internal water circuit is empty.	Fill the water tank with fresh tap water up to the MAX indication. Press the lungo button to fill the internal circuit.
Why do I find water in the waste water drawer?	The used capsule drawer and waste water drawer catch the residual water released after brewing coffee.	This is normal.

Problem	Possible cause	Solution
After the rinsing cycle, the orange service indicator light continues to flash and the yellow lungo button lights up continuously.	The internal circuit has not been rinsed sufficiently.	Repeat steps 13-17 in chapter 'Descaling the machine', section 'Descaling procedure' once more. Make sure the water tank is filled up to the MAX indication.

Warranty

IMPORTANT:

Please keep this warranty card together with your proof of purchase for use when claiming.

NEW ZEALAND
Jalmac Sales + Marketing Ltd.
Consumer Care: 0800 726 713
Website: www.mapcoffee.com

In this warranty:

We or **us** means Jalmac Sales + Marketing Ltd. and our contact details are set out at the end of this warranty;

You means the purchaser or the original end-user of the Goods;

Supplier means the authorised distributor or retailer of the Goods that sold you the Goods in New Zealand; and

Goods means the product or equipment which was accompanied by this warranty and purchased in New Zealand.

If you require assistance with the operation of the product, its features or specifications please call on 0800 726 713 in New Zealand.

New Zealand: Our Goods come with guarantees that cannot be excluded under the Consumer Guarantees Act 1993.

This guarantee applies in addition to the conditions and guarantees implied by that legislation.

Additional Warranty:

In addition to the rights and remedies that you have under the Consumer Guarantees Act of New Zealand or any other applicable law, we provide the following warranty against defects:

1. If, during the first **2 years** from their date of purchase from the Supplier (**Warranty Period**), the Goods prove defective by reason of improper workmanship or materials and none of your statutory rights or remedies apply, we will repair or replace the Goods without charge.
2. We do not have to repair or replace the Goods under this Additional Warranty if the Goods have been used for a commercial purpose; misused, improperly or inappropriately installed, operated or repaired; abused; damaged; or not maintained in accordance with the manufacturer's instructions.
3. Even when we do not have to repair or replace the Goods, we may decide to do so anyway. In some cases, we may decide to substitute the Goods with a similar alternative product of our choosing. All such decisions are at our absolute discretion.
4. All such repaired, replaced or substituted Goods continue to receive the benefit of this Additional Warranty for the time remaining on the original Warranty Period.
5. This Additional Warranty is limited to repair, replacement or substitution only. As far as the law permits, we will not be liable for any loss or damage caused to property or persons arising from any cause whatsoever.
6. In order to claim under this Additional Warranty you must telephone us on 0800 726 713 in New Zealand within the Warranty Period. You will be asked for details of the Goods, a description of the defect and your personal details. Upon accepting your claim, we shall assist you with either returning the Goods to the Supplier for replacement or to the most convenient Jalmac Sales and Marketing Service Centre for your Goods to be repaired.
 In some case we may require that you return to the Goods to us (at the address below) for repair, replacement or substitution.
 - * All returned Goods must be accompanied by satisfactory proof of purchase which clearly indicates the name and address of the Supplier; the date and place of purchase and identifies product. It is best to provide a legible and unmodified receipt or sales invoice.
 - * You must bear any expense for return of the Goods or otherwise associated with making your claim under this Additional Warranty.
7. This warranty is only valid and enforceable in New Zealand.

Contact us or the place of purchase for further details.

Jalmac Sales + Marketing Ltd.
 108 Izone Drive,
 Rolleston 7675
 Canterbury, New Zealand
 Consumer Care: 0800 726 713
 E-mail: admin@jalmacsales.com
 Website: www.mapcoffee.com

