

PHILIPS

HR3571
HR3573



- | | |
|-----------------------|-------------------------|
| EN User manual | IT Manuale utente |
| DA Brugervejledning | NL Gebruiksaanwijzing |
| DE Benutzerhandbuch | NO Brukerhåndbok |
| EL Εγχειρίδιο χρήσης | PT Manual do utilizador |
| ES Manual del usuario | SV Användarhandbok |
| FI Käyttöopas | TR Kullanım kılavuzu |
| FR Mode d'emploi | |



© 2021 Philips Domestic Appliances Holding B.V.
All rights reserved.
3000.048.3726.6 (23/07/2021)



1

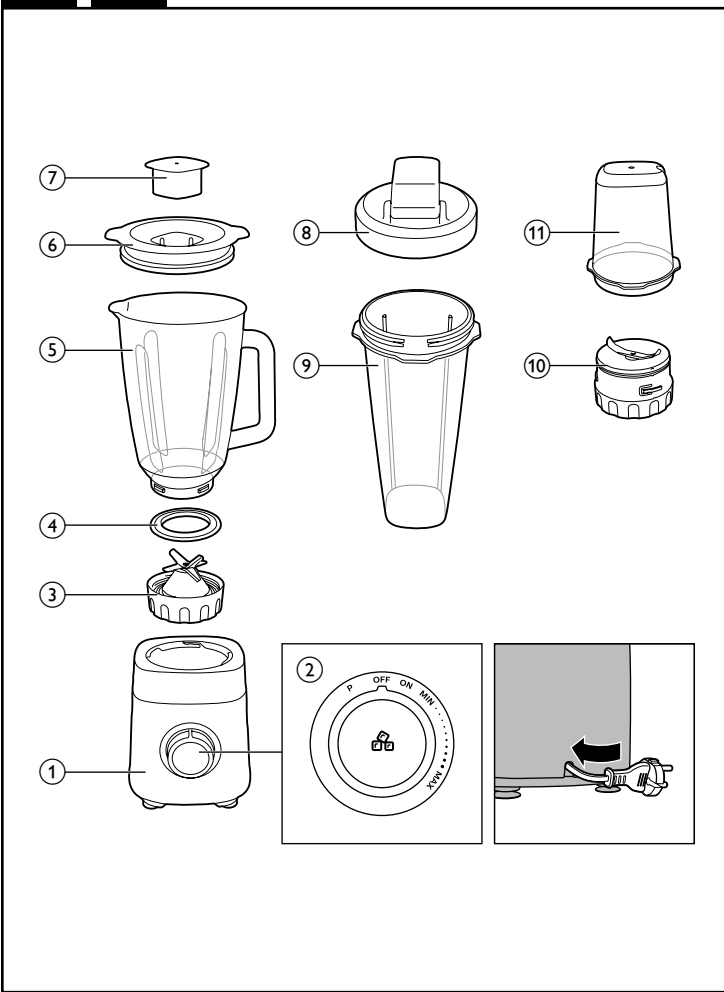

English

- Motor unit with control knob
 - Rotary knob and preset settings
 - MIN/MAX/ON: to turn on the blender and select a blending speed setting.
 - OFF: to turn off the blender.
 - : to crush ice.
 - P: to blend briefly and for easy clean.
 - Blender blade unit
 - Sealing ring
 - Blender jar
 - Lid of blender jar
 - Small covering lid
- Tumbler (HR3573 only)**
- Tumbler lid
 - Tumbler jar
- Mill (Available for some countries ONLY)**
- Mill blade unit
 - Mill jar

Dansk

- Motorenhed med kontrolknop
- Drejeknap og forudindstillinger
 - MIN/MAX/ON: Tænd for blendersen, og vælg en hastighedsindstilling.
 - OFF: Sluk for blendersen.
 - : for at knuse is.
 - P: for at knuse is.
- Blenderknive
- Tætningsring
- Blenderglas
- Låg til blenderglas
- Lille dæksel

Bæger (kun HR3573)

- Låg til beholder
 - Beholderglas
- Møllekværn (KUN tilgængelig i nogle lande)**
- Mølle-knivenhed
 - Beholder til møllekværn

Deutsch

- Motoreinheit mit Drehschalter
- Drehknopf und Voreinstellungen
 - MIN/MAX/ON: zum Einschalten des Mixers und zum Auswählen der Mixergeschwindigkeitsstufe.
 - OFF: zum Ausschalten des Mixers.
 - : zum Zerkleinern von Eis.
- Mixermessereinheit
- Dichtungsring
- Mixbehälter
- Deckel des Mixbehälters
- SDeckel für Mühle

Becher (nur HR3573)

- Deckel für Becher
 - Becherbehälter
- Mühle (NUR in einigen Ländern verfügbar)**
- Mühlmesserereinheit
 - Mühlbehälter

Ελληνικά

- Μοτέρ με διακόπτη ελέγχου
 - Περιστροφικός διακόπτης και προκαθορισμένες ρυθμίσεις
 - MIN/MAX/ON: Για να ενεργοποιήσετε το μπλέντερ και να επιλέξετε μια ρύθμιση ταχύτητας ανάμειξης.
 - OFF: Για να απενεργοποιήσετε το μπλέντερ.
 - : Για θρυμματισμό πάγου.
 - Λεπίδες μπλέντερ
 - Δακτύλιος σφράγισης
 - Κανάτα μπλέντερ
 - Καπάκι κανάτας μπλέντερ
 - Μικρό καπάκι κάλυψης
- Δοχείο (HR3573 μόνο)**
- Καπάκι δοχείου
 - Κανάτα δοχείου
- Μύλος (Διατίθεται MONO σε ορισμένες χώρες)**
- Λεπίδες μύλου
 - Κανάτα μύλου

Español

- Unidad motora con rueda de control
 - Control giratorio y ajustes predeterminados
 - MIN/MAX/ON: Para encender la batidora y seleccionar una posición de velocidad de batido.
 - OFF: Para apagar la batidora.
 - : Para picar hielo.
 - Unidad de cuchillas de la batidora
 - Junta
 - Jarra de batidora
 - Tapa de la jarra de la batidora
 - Tarapapeña
- Vaso portátil (solo modelo HR3573)**
- Tapa del vaso portátil
 - Jarra del vaso portátil
- Molinillo (Disponible SOLO en algunos países)**
- Unidad de cuchillas del molinillo
 - Jarra del molinillo

Suomi

- Runko ja ohjauksainike
 - Valintanappi ja esivalinta-asetukset
 - MIN/MAX/ON: tehosekoittimen käynnistämiseen ja sekoittimen nopeusasetuksen valintaan.
 - OFF: tehosekoittimen virran katkaisemiseen.
 - : jään murskaamiseen.
 - Tehosekoittimen teräyksikkö
 - Tiiviste
 - Sekoituskuhlo
 - Sekoituskuhlon kansi
 - Spieni suojakansi
- Juomalasi (vain HR3573)**
- Juomalasin kansi
 - Juomalasikannu
- Maustemylly (Saatavilla vain joissakin maissa)**
- Hienonnuososa
 - Maustemyllyn astia

Français

- Bloc moteur avec bouton de commande
 - Bouton rotatif et présélections
 - MIN/MAX/ON : pour allumer le blender et sélectionner une vitesse de mixage.
 - OFF: pour éteindre le blender.
 - : pour piler de la glace.
 - Ensemble lames du blender
 - Bague d'étanchéité
 - Blender
 - Couvercle du blender
 - Setit couvercle
- Gourde (HR3573 uniquement)**
- Couvercle du verre isotherme
 - Gourde isotherme
- Moulin (Disponible pour certains pays UNIQUEMENT)**
- Ensemble lames du moulin
 - Bol du moulin

Italiano

- Blocco motore con manopola di controllo
 - Manopola e impostazioni predefinite
 - MIN/MAX/ON: per accendere il frullatore e selezionare un'impostazione di velocità.
 - OFF: per spegnere il frullatore.
 - : per tritare il ghiaccio.
 - Gruppo lame frullatore
 - Anello di guarnizione
 - Vaso frullatore
 - Coperchio del vaso frullatore
 - Coperchio piccolo
- Bicchiere (solo HR3573)**
- Coperchio del bicchiere
 - Vaso del bicchiere

Tritatutto (Disponibile SOLO per alcuni paesi)

- Lama tritatutto
- Vaso tritatutto

Nederlands

- Motorunit met bedieningsknop
 - Draaiknop en voorgeprogrammeerde instellingen
 - MIN/MAX/ON: om de blender in te schakelen en te selecteren voor het mengen.
 - OFF: om de blender uit te schakelen.
 - : om ijs te vermalen.
 - Mesunit van blender
 - Afdichting
 - Blenderbeker
 - Deksel van blenderkan
 - SKlein dekseltje
- Tumbler (alleen HR3573)**
- Tumblerdeksel
 - Tumblerkan
- Maalmolen (ALLEEN voor sommige landen beschikbaar)**
- Mesunit van maalmolen
 - Maalmolenbeker

Norsk

- Motorenhet med bryter
 - Roterende bryter og forhåndsinnstillinger
 - MIN/MAX/ON: for å slå på hurtigmikseren og velge en hastighetsinnstilling for miksing.
 - OFF: for å slå av hurtigmikseren.
 - : for å knuse is.
 - Knivenhet for hurtigmikser
 - Gummipakring
 - Mikserkanne
 - Lokk til mikserkanne
 - Lokk for kvern
- Shakebeholder (kun HR3573)**
- Lokk for mikserkanne
 - Kolbe for mikserkanne
- Kvern (KUN tilgjengelig i enkelte land)**
- Knivenhet for kvern
 - Kvernbeholder

Português

- Motor com botão de controlo
 - Botão rotativo e predefinições
 - MIN/MAX/ON: para ligar a liquidificadora e seleccionar uma regulação de velocidade de liquidificação.
 - OFF: para desligar a liquidificadora.
 - : para picar gelo.
 - Lâmina da liquidificadora
 - Anel vedante
 - Copo misturador
 - Tampa do copo misturador
 - STampa pequena
- Copo para levar (apenas HR3573)**
- Tampa do copo para levar
 - Corpo do copo para levar
- Moinho (APENAS disponível em alguns países)**
- Lâminas do moinho
 - Copo do moinho

Svenska

- Motorenhet med kontrollvred
 - Vred och förinställningar
 - MIN/MAX/ON: för att slå på mixern och välj en mixerhastighet.
 - OFF: för att stänga av mixern.
 - : för att knusa is.
 - Knivenhet för mixer
 - Tätningring
 - Mixerbehållare
 - Lock till mixerbehållare
 - Litet lock
- Drickmugg (endast HR3573)**
- Lock till drickmugg
 - Drickmugg
- Kvorn (Tillgängligt ENDAST för vissa länder)**
- Knivenhet för kvorn
 - Kvornbägare

Drickmugg (endast HR3573)

- Lock till drickmugg
 - Drickmugg
- Kvorn (Tillgängligt ENDAST för vissa länder)**
- Knivenhet för kvorn
 - Kvornbägare

Türkçe

- Kontrol düğmesi motor ünitesi
 - Döner düğme ve ön ayarlar
 - MIN/MAX/ON (MIN/MAKS/AÇIK): Blenderi açmak ve bir karıştırma hızı ayarı seçmek için kullanılır.
 - OFF (KAPALI): Blenderi kapatmak için kullanılır.
 - : Buz kırma için kullanılır.
 - Blender bıçak ünitesi
 - Halka conta
 - Blender haznesi
 - Blender haznesinin kapağı
 - Küçük kapak
- Sürahi (yalnızca HR3573)**
- Sürahi kapağı
 - Sürahi haznesi

Öğütücü (YALNIZCA bazı ülkelerde mevcuttur)

- Öğütücü bıçağı ünitesi
- Öğütücü haznesi

5

		kg (MAX)		
		1500 ml	MAX	60 - 90 sec.
		1500 ml	MAX	60 - 90 sec.
		1500 ml	MAX	30 - 60 sec.
		6 x		1 min
		200 g	MAX	1 min
		300 ml		
		200 g	MAX	1 min
		250 ml		
		25 - 50 g	P	30 sec.
		5 - 25 g	P	30 sec.
		25 - 75 g	P	30 sec.
		20-40 g	P	10 sec.
		100 g	P	10 sec.
				2x2x2 cm

English

Before first use
Thoroughly clean the parts that will come in contact with food before you use the appliance for the first time (see chapter "Cleaning").

- Note**
- Do not exceed the maximum quantities and processing times indicated in Fig.5.
 - Do not operate the appliance for more than 60 seconds at a time when processing heavy loads and let it cool down to room temperature for next operation.
 - Do not attempt to process very thick recipes such as bread dough or mash potatoes.

Blender (Fig 2)

- The blender is intended for:
- Blending fluids, e.g. dairy products, sauces, fruit juices, soups, mixed drinks, shakes.
 - Mixing soft ingredients, e.g. pancake batter or mayonnaise.
 - Pureeing cooked ingredients.

- Note**
- Never overflow the blender jar above the maximum level indication (1.5 litres) to avoid spillage.

Pulse and ice crushing function

To process ingredients briefly (such as garlic), rotate the rotary knob to the P (PULSE) position.

To crush ice, press the ice crushing button. To stop, turn the rotary knob to the OFF position.

- Tip**
- To process ingredients very briefly, rotate the rotary knob to the P (PULSE) position several times.
 - To crush ice, press the ice crushing button. To stop, the ice crushing button again or turn the rotary knob to the OFF position.
 - Never use the pulse function longer than a few seconds at a time.

Tumbler (Fig 3)

Make your smoothies or shakes directly with the tumbler. Remove the blade unit and attach the lid of the tumbler. Then you can bring the tumbler out and enjoy directly.

- Note**
- Never overflow the tumbler jar above the maximum level indication to avoid spillage.
 - Never fill the tumbler jar with soft drinks to avoid spillage.

Cleaning (Fig 6)

Easily cleaning the blender jar: Follow the steps: 1 2 3 4.

Note: Make sure to rotate the rotary knob to P (Pulse) position a few times.

Motor overheat protection
This appliance is equipped with overheat protection. If the appliance overheats, it switches off automatically. Unplug the appliance and let it cool down for 30 minutes. Then put the mains plug back into the power outlet and switch on the appliance again. Please contact your Philips dealer or an authorized Philips service center if the overheat protection is activated too often.

Dansk

Før apparatet tages i brug

Sørg for at rengøre de dele, der kommer i berøring med mad, inden du bruger apparatet for første gang (se afsnittet "Rengøring").

- Bemærk**
- Undgå at overskride de angivne mængder og tilberedningstider angivet i Fig. 5.
 - Lad ikke apparatet køre i mere end 60 sekunder ad gangen, når du behandler større mængder, og lad det køle ned til stuetemperatur, før det bruges igen.
 - Forsøg ikke med mad, der har en meget tyk konsistens som f.eks. dej eller kartoffelmos.

Blender (Fig. 2)

- Blenderen er beregnet til:
- Blending af flydende ingredienser, f.eks. mejeriprodukter, sauce, frugtjuice, suppe, mixede drinks og shakes.

2

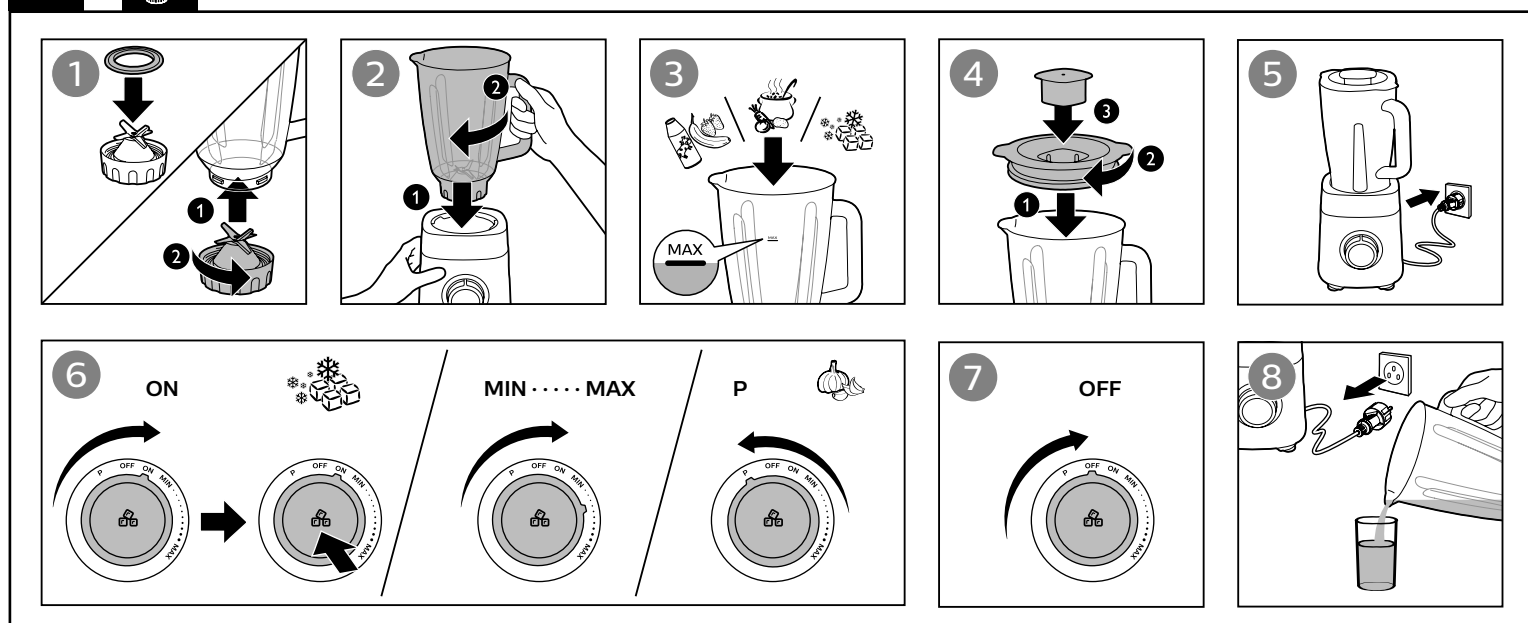

6

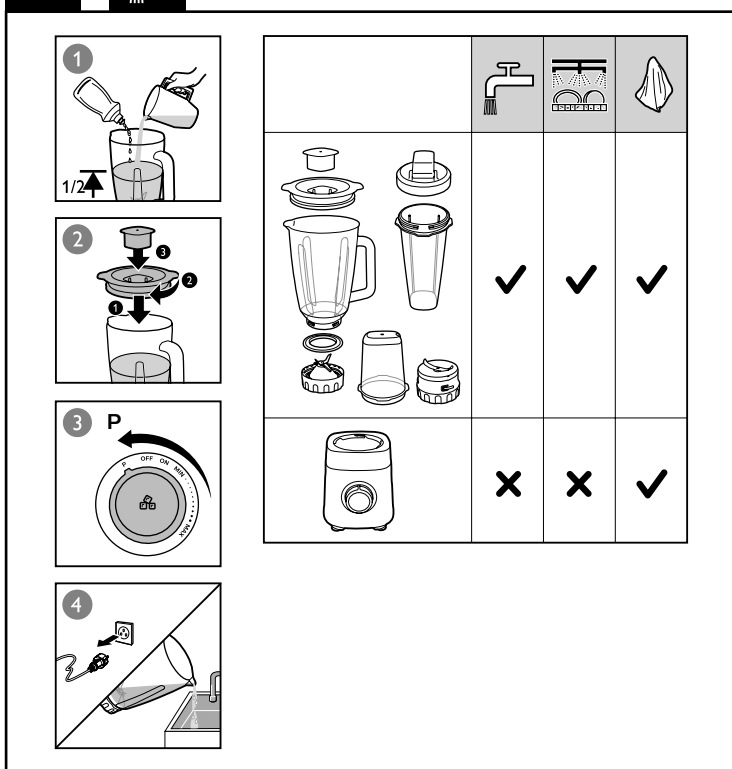

3

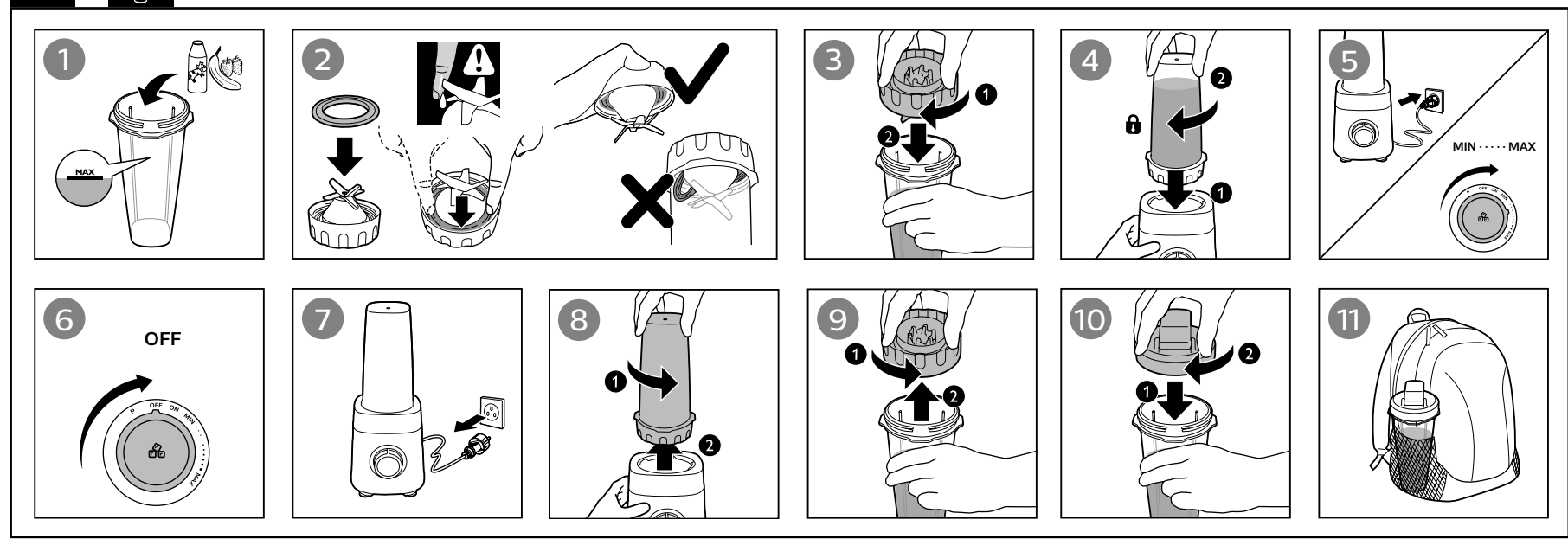

4

