

PHILIPS

HD2238



User manual



PHILIPS and the Philips Shield Emblem are registered trademarks of Koninklijke Philips N.V. and are used under license. This product has been manufactured by and is sold under the responsibility of Versuni Holding B.V., and Versuni Holding B.V. is the warrantor in relation to this product.

2023 © Versuni Holding B.V.

6608.000.0790.4 (27/04/2023)



English

1 Your All-in-one Multi Cooker

Congratulations on your purchase, and welcome to Philips!
To fully benefit from the support that Philips offers, register your product at www.philips.com/welcome.

2 Important

Safety

Read this user manual carefully before you use the appliance, and save it for future reference.

Danger

- The appliance must not be immersed.

Warning

- Check if the voltage indicated on the appliance corresponds to the local power voltage before you connect it.
- The appliance is intended to be used in household or similar applications such as:
 - staff kitchen areas in shops, offices, and other residential type environments;

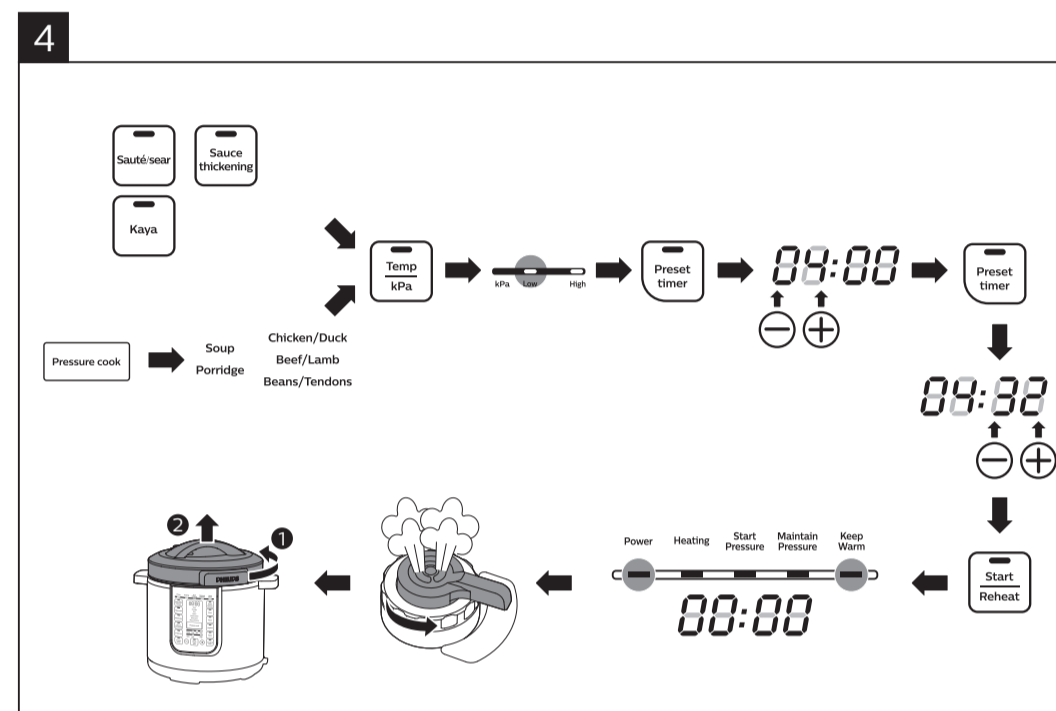
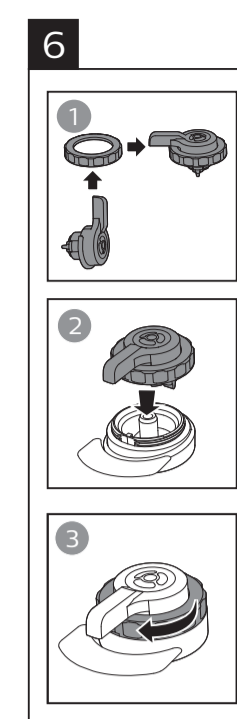
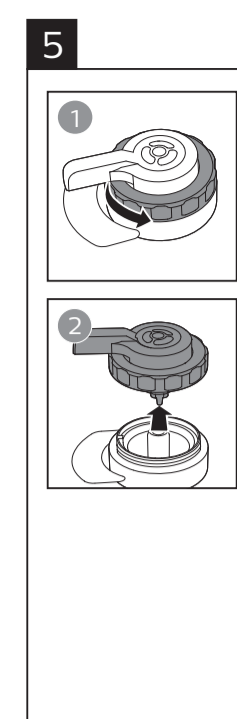
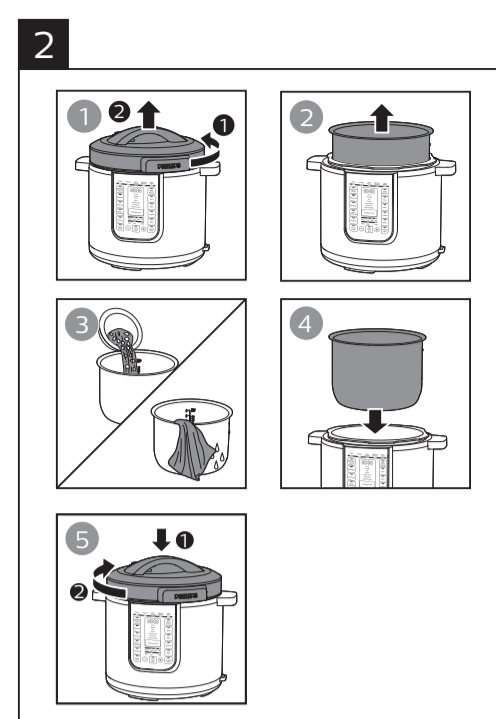
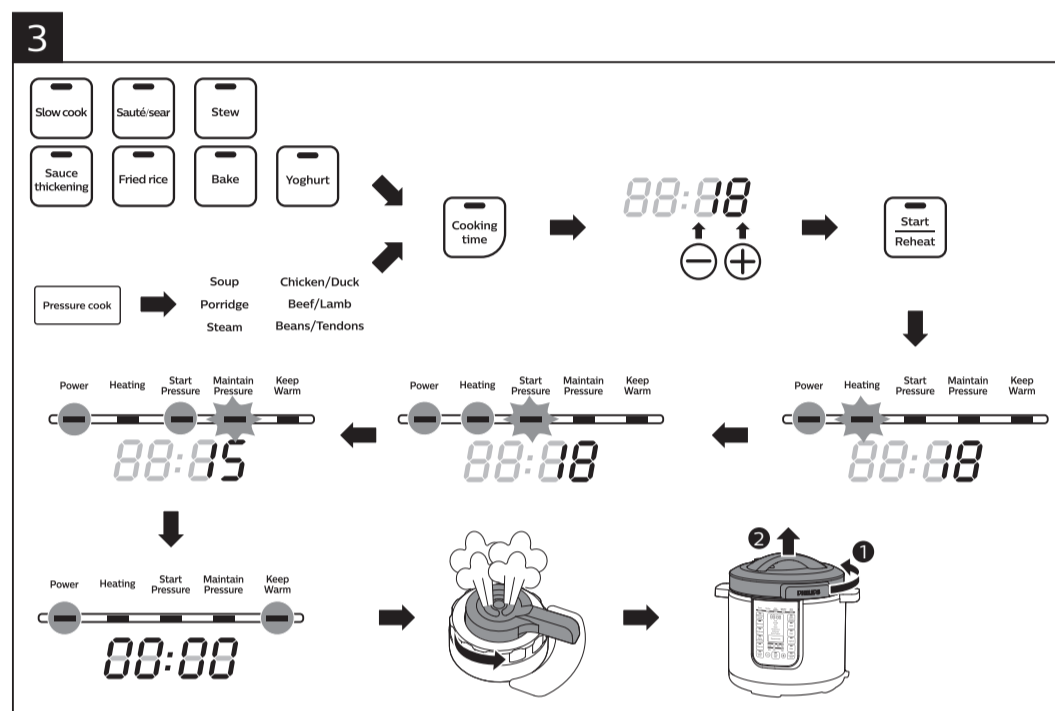
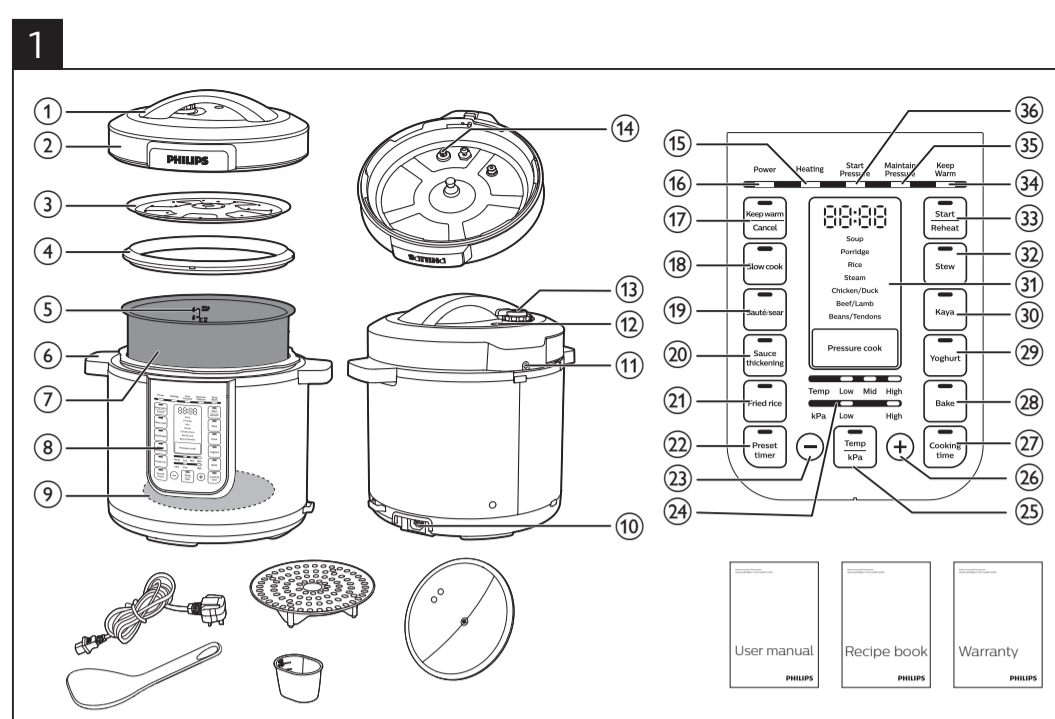

- farm houses;
- by clients in hotels, motels and other residential type environments;
- bed and breakfast type environments.
- This appliance is not intended for use by persons (including children) with reduced physical, sensory or mental capabilities, or lack of experience and knowledge, unless they have been given supervision or instruction concerning use of the appliance by a person responsible for their safety.
- Children should be supervised to ensure that they do not play with the appliance.

- If the power cord set is damaged, it must be replaced by a cord set available from the manufacturer.
- The appliance is not intended to be operated by means of an external timer or a separate remote-control system.
- The ducts in the pressure regulator allowing the escape of steam should be checked regularly to ensure that they are not blocked.
- The container must not be opened until the pressure has decreased sufficiently.
- Cleaning and user maintenance shall not be made by children.
- Keep the appliance and its cord out of reach of children.

- WARNING: Always follow the instructions and use the appliance properly to avoid potential injury.
- According to the instructions prescribed in this user manual, use a soft damp cloth to clean the surfaces in contact with food and make sure to remove all the food residues stuck to the appliance.
- WARNING: Make sure to avoid spillage on the power connector to avoid a potential hazard.
- Use clean and soft cloth to clean the surfaces in contact with food.
- Only connect the appliance to a grounded power outlet. Always make sure that the plug is inserted firmly into the power outlet.

- Do not use the appliance if the plug, the power cord, the inner pot, the sealing ring, or the main body is damaged.
- Do not let the power cord hang over the edge of the table or worktop on which the appliance stands.
- Make sure the heating element, the temperature sensor, and the outside of the inner pot are clean and dry before you put the plug in the power outlet.
- Do not plug in the appliance or turn the control knob with wet hands.
- Make sure the power socket is clean and dry before you plug in the appliance.

- Do not use the appliance if too much air or steam is leaking from under the top lid.
- When cooking soup or viscous liquid, do not release pressure by turning the pressure regulator to the steam vent position, otherwise liquid might spurt from the pressure regulator valve. Wait until the pressure is naturally released and the floater has dropped to open the top lid.

Caution

- CAUTION: Surface of the heating element is subject to residual heat after use.
- Never use any accessories or parts from other manufacturers or that Philips does not specifically recommend. If you use such accessories or parts, your guarantee becomes invalid.
- Do not expose the appliance to high temperatures, nor place it on a working or still hot stove or cooker.
- Do not expose the appliance to direct sunlight.
- Place the appliance on a stable, horizontal, and level surface.
- Do not use the handle on the top lid to move the appliance, use the side handles instead.
- When pressure is being released from the pressure regulator valve, hot steam or liquid will be ejected. Keep hands and face away from the steam vent.

