

PHILIPS

HD2145



User Manual



Contents

1 Important	4	4 Cleaning and Maintenance	21
Power failure backup function	7	Inner lid	21
Electromagnetic fields (EMF)	7	Steam valve	21
		Floater	22
		Pressure regulator	22
		Interior	23
		Exterior	23
		Accessories and inner pot	23
2 Your All-in-One cooker	8		
What's in the box	8	5 Recycling	24
Product overview	9		
Control panel overview	10	6 Guarantee and service	24
3 Using your All-in-One cooker	11	7 Specifications	24
Before first use	11		
Cooking program	12	8 Troubleshooting	25
Preparations before cooking	13		
Pressure cooking	14		
Adding ingredient	16		
Multi-cooking	17		
Sauce thickening	18		
Preset time for delayed cooking	19		
Setting up child lock	19		
Setting up My Favourite menu	20		

1 Important

Read this safety leaflet carefully before you use the appliance and save it for future reference.

Danger

- The appliance must not be immersed.

Warning

- This appliance is intended to be used in household and similar applications such as:
 - staff kitchen areas in shops, offices and other working environments;
 - farm houses;
 - by clients in hotels, motels and other residential type environments;
 - bed and breakfast type environments.
- This appliance is not intended for use by persons (including children) with reduced physical, sensory or mental capabilities, or lack of experience and knowledge, unless

they have been given supervision or instruction concerning use of the appliance by a person responsible for their safety.

- Children should be supervised to ensure that they do not play with the appliance.
- If the power cord set is damaged, it must be replaced by a cord set available from the manufacturer.
- The appliance is not intended to be operated by means of an external timer or a separate remote-control system.
- The ducts in the pressure regulator allowing the escape of steam should be checked regularly to ensure that they are not blocked.
- The container must not be opened until the pressure has decreased sufficiently.
- WARNING: Make sure to avoid spillage on the power connector to avoid a potential hazard.

- **WARNING:** Always follow the instructions and use the appliance properly to avoid potential injury.
- Use a clean and soft cloth to clean the surfaces in contact with food.
- Only connect the appliance to a grounded power outlet. Always make sure that the plug is inserted firmly into the power outlet.
- Do not use the appliance if the plug, the power cord, the inner pot, the sealing ring, or the main body is damaged.
- Do not let the power cord hang over the edge of the table or worktop on which the appliance stands.
- Make sure the heating element, the temperature sensor, and the outside of the inner pot are clean and dry before you put the plug in the power outlet.
- Do not plug in the appliance or turn the control knob with wet hands.

- Make sure the power socket is clean and dry before you plug in the appliance.
- Do not use the appliance if too much air or steam is leaking from under the top lid.

Caution

- **CAUTION:** Surface of the heating element is subject to residual heat after use.
- Never use any accessories or parts from other manufacturers or that Philips does not specifically recommend. If you use such accessories or parts, your guarantee becomes invalid.
- Do not expose the appliance to high temperatures, nor place it on a working or still hot stove or cooker.
- Do not expose the appliance to direct sunlight.
- Place the appliance on a stable, horizontal, and level surface.
- When pressure is being released from the

- pressure regulator valve, hot steam or liquid will be ejected. Keep hands and face away from the steam vent.
- Always put the inner pot in the appliance before you put the plug in the power outlet and switch it on.
 - Do not place the inner pot directly over an open fire to cook food.
 - Do not use the inner pot if it is deformed.
 - Make sure that the sealing ring is clean and in good condition.
 - The accessible surfaces may become hot when the appliance is operating. Take extra caution when touching the surfaces.
 - Beware of hot steam coming out of the floating valve and pressure regulator valve during cooking or when you open the lid. Keep hands and face away from the appliance to avoid the steam.
 - Do not lift and move the appliance while it is operating.
 - Do not exceed the maximum water level indicated in the inner pot to prevent overflow.
 - Do not place the cooking utensils inside the pot while cooking.
 - Only use the cooking utensils provided. Avoid using sharp utensils.
 - To avoid scratches, it is not recommended to cook ingredients with crustaceans, shellfish and meats with protruding bones. Remove the hard shells or excessive bone before cooking.
 - Do not place a magnetic substance on the lid. Do not use the appliance near a magnetic substance.
 - Always let the appliance cool down to room temperature before you clean or move it.
 - Always clean the appliance after use. The detachable inner lid, including its

components can be put into the dishwasher for clean, but other parts of the appliance can not be washed in the dishwasher.

- Always unplug the appliance if not used for a longer period.
- If the appliance is used improperly or for professional or semi-professional purposes, or if it is not used according to the instructions in this safety leaflet, the guarantee becomes invalid and Philips refuses liability for any damage caused.
- Visit www.philips.com/support to download the user manual.

Power failure backup function

This appliance has a backup function that reserves the status before a power failure.

- If the power failure occurs during a cooking process, and the power supply is resumed within 30 minutes, the countdown of the cooking time continues where it is left off.
- If the power failure occurs when the appliance is at preset mode, and the power supply is resumed within

30 minutes, the countdown of the preset time continues where it is left off.

- If the power supply is not resumed within 30 minutes, the appliance might not continue with the previous working process, but stay in standby mode.

Electromagnetic fields (EMF)

This Philips appliance complies with all applicable standards and regulations regarding exposure to electromagnetic fields.

2 Your All-in-One cooker

Congratulations on your purchase, and welcome to Philips!

To fully benefit from the support that Philips offers, register your product at www.Philips.com/welcome.

What's in the box

Main unit	Steaming plate
Inner Pot	Rice&Soup ladle
Measuring cup	Power cord
detachable inner lid	User manual
Recipe book	Warranty card

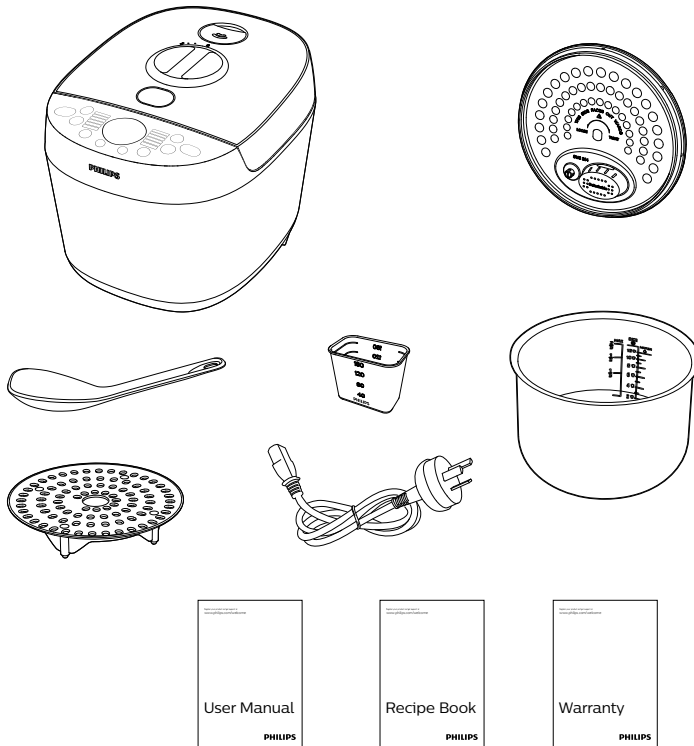

Product overview

①	Top lid	⑩	Water level indication
②	Sealing ring	⑪	Control panel
③	Detachable inner lid	⑫	Temperature controller
④	Cap nuts	⑬	Power socket
⑤	Safety valve	⑭	Lid open button
⑥	Anti-block cap	⑮	Lid lock/unlock handle
⑦	Fixing nut	⑯	Steam valve
⑧	Floating valve	⑰	Pressure regulator
⑨	Inner pot		

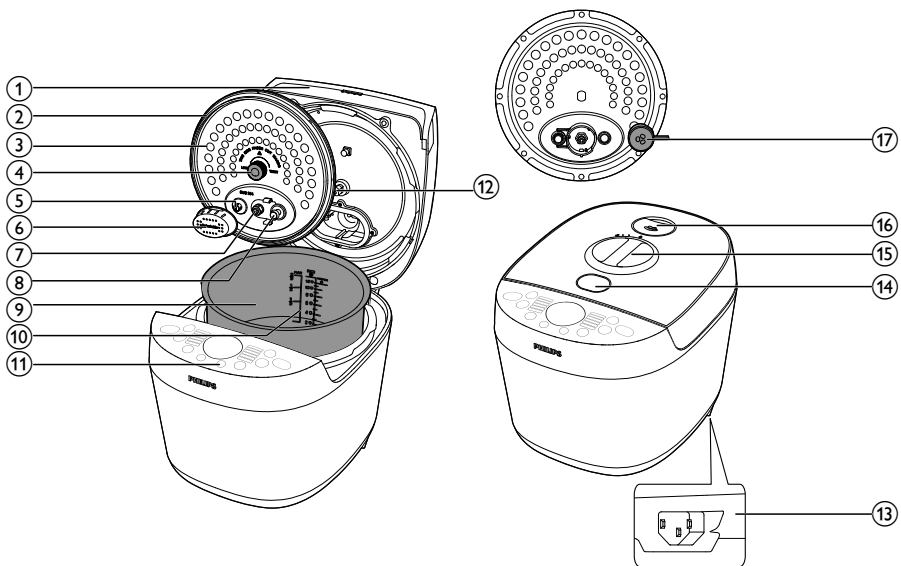

Control panel overview

18	Cooking process indicator	26	Pressure display
19	Sauce thickening button	27	Lid unlocked indicator
20	Keep warm/Cancel button	28	Pressure selection button
21	My favourite button	29	Reheat/child lock button
22	Timer/Delayed button	30	Start button
23	Lid locked indicator	31	Add ingredient button
24	Menu selection button	32	Display panel
25	My favourite indicator		

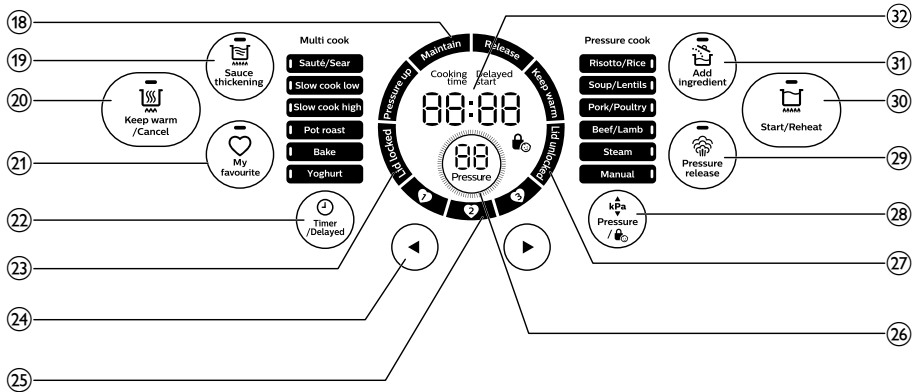

3 Using your All-in-One cooker

Before first use

- 1 Remove all packaging materials from the appliance.
- 2 Take out all the accessories from the inner pot.
- 3 Clean the parts of the All-in-One cooker thoroughly before using it for the first time (see chapter "Cleaning and Maintenance").



Note

- Make sure all parts are completely dry before you start using the All-in-One cooker.
- Make sure the inner pot is in proper contact with the heating element.

Cooking program

Multi-cooking programs

Cooking function	Cooking temperature	Default cooking time	Adjustable cooking time
Sauté/Sear*	150°C	2 minutes	2-59 minutes
Slow cook low	70°C	8 hours	2-12 hours
Slow cook high	90°C	6 hours	2-12 hours
Pot roast	90°C	6 hours	2-12 hours
Bake	126°C	45 minutes	40-59 minutes
Yoghurt	40°C	8 hours	6-12 hours
Reheat	105°C	10 minutes	\

*The preheat time of Sauté/Sear may take up to 5 minutes.

Pressure cooking programs

Cooking function	Default cooking time (minute)	Adjustable cooking time (minute)	Default pressure (kPa)	Adjustable pressure regulating range(kPa)
Risotto/Rice	14	\	30	\
Soup/Lentils	20	20-59	50	20-50
Pork/Poultry	15	12-59	40	20-70
Beef/Lamb	40	30-59	60	20-70
Steam**	8	3-20	10	\
Manual	5	2-59	20	20-70

**Steam will be released intermittently from the steam valve during cooking. This is to have optimal airflow and to ensure cooking result.

Note: When pressure starts to build up, the All-in-One cooker will automatically release cold air from the inner pot through the steam valve. This is to make sure sensor can accurately sense and control the temperature and pressure inside.

Note: Cooking pressure can be adjusted to reach your preferred texture. You may increase the cooking pressure to have an even more tender result, or decrease the cooking pressure if you find the texture to be too soft.

Preparations before cooking

! Warning

- Make sure that the steam valve is not blocked and the detachable inner lid is properly installed.

☰ Note

- Do not fill the inner pot with food and liquid less than the minimum of the water level indications, or more than the maximum of the water level indications.
- For food that expands (such as beans or dried foods) during cooking, do not fill the inner pot with more than 1/2 full of food and liquid.
- For rice cooking, follow the water level indications on the inside of the inner pot. You can adjust the water level for different types of rice and according to your own preference. Do not exceed the maximum quantities indicated on the inside of the inner pot.
- After the cooking process is started, you can press **Cancel/Warm** to terminate the current work, and the appliance goes to standby mode.

Perform the following preparations before cooking with the All-in-One cooker:

- 1 Turn the lid lock/unlock handle counter clockwise to  position.

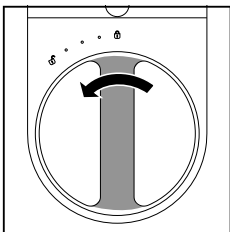

- 2 Press the lid open button to open the top lid.

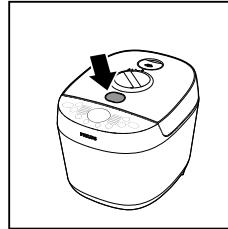

- 3 Take out the inner pot from the All-in-One cooker.

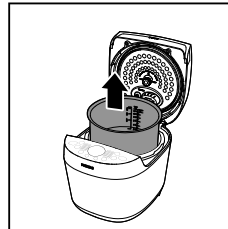

- 4 Put the pre-washed food in the inner pot, wipe the outside and bottom of the inner pot dry (fig 1) with soft cloth, then put it back into the All-in-One cooker (fig 2).

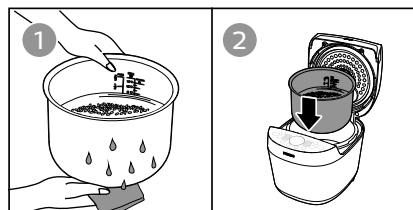

- 5 Turn the handle clockwise to lock the top lid.

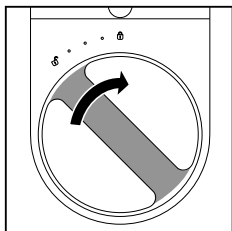

- 6 Put the plug into the power socket.

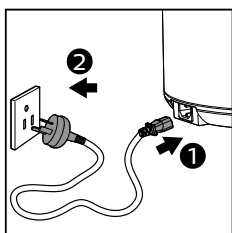

Note

- Make sure the outside of the inner pot is dry and clean, and that there is no foreign residue on the heating element.
- Make sure the inner pot is in proper contact with the heating element.

Pressure cooking

Risotto/Rice, Soup/Lentils, Pork/Poultry, Beef/Lamb, Steam and Manual are pressure cooking functions. About the information of the pressure cooking time and pressure regulating range, refer to Chapter "Functions Overview".

- 1 Follow the steps in "Preparations before cooking".

- 2 Tap ► to choose one of the pressure cooking functions.

- ↳ The chosen cooking function lights up, the default pressure keeping time and pressure are displayed on the screen.

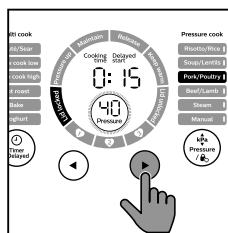

- 3 To set a different pressure keeping time, tap Timer/Delayed, Cooking time lights up.



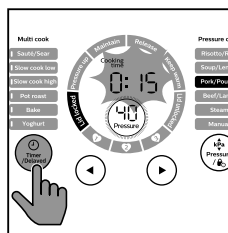

- ↳ The pressure keeping time blinks.

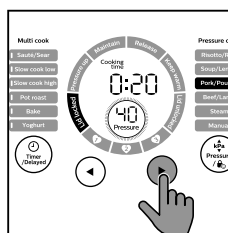

- 4 Tap ◀/▶ to set the cooking time. For the cooking time adjustable range, refer to Chapter "Cooking time regulating range".





Tips

- Tap  to adjust the time by hours, tap  to adjust the time by minutes. Tap and hold  /  to fast forward or fast backward time.
- The cooking time is not adjustable for **Risotto/Rice**.
- Tap **Keep warm/Cancel** button to cancel cooking time setting.

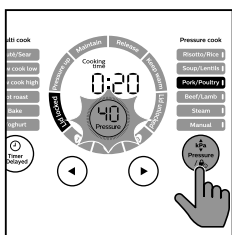
- 5 To set a different cooking pressure, tap **Pressure** button.
↳ The pressure blinks on the screen.



- 6 Tap  /  to choose the pressure you need.

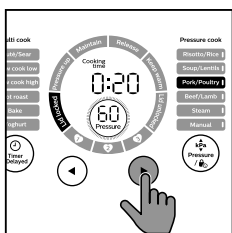

Note

- You may increase the cooking pressure to achieve an even more tender result according to your preference, while decrease the cooking pressure if you find the texture to be too soft.
- Only the pressure level for the following functions are adjustable: Soup/Lentils, Pork/Poultry, Beef/Lamb and Manual.
- Tap **Keep warm/Cancel** to cancel the pressure setting.

- 7 Tap and hold **Start/Reheat** for 3 seconds, the All-in-One cooker starts working in the selected mode.

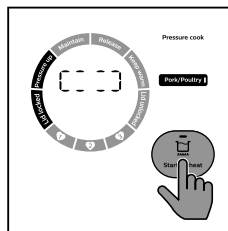

- 8 When the All-in-One cooker reaches the cooking pressure, the pressure keeping time starts countdown.
- 9 When the pressure keeping time has elapsed, The All-in-One cooker steps into "Release" stage, you can tap **Pressure release** button to quickly release the pressure, or wait until the cooker cools down naturally.

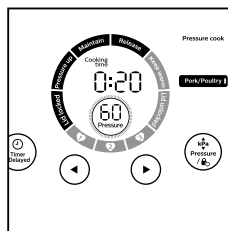

- 10 The All-in-One cooker automatically switches to keep warm mode after pressure is released completely. You can unlock and open the top lid.

Note

- You can tap the **Pressure release** button to quickly release the pressure.
- Wait until the All-in-One cooker cools down naturally to open the lid if you don't tap the **Pressure release** button.
- After the cooking process is finished, unplug the All-in-One cooker from the electrical outlet.

Adding ingredient

With this function, you can open the lid during pressure cooking process and add more ingredients.

Note

- The **Add ingredient** function is not available for the Risotto/Rice and Sauce thickening functions.

1 In standby mode, tap ◀/▶ to choose the function you need, and then tap **Add ingredient**.

- ↳ Tap and hold **Start/Reheat** for 3 seconds to start the cooking process. When the remaining cooking time is 10 minutes left, the current cooking process pauses, the All-in-One cooker beeps and starts to release pressure.

Note

- If the pressure cooking time is less than 10 minutes, you use this function by tapping **Add ingredient** directly during cooking process.

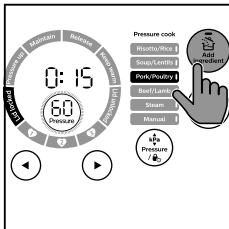

2 You can also tap **Add ingredient** anytime during pressure maintain process.

- ↳ The current cooking process pauses, the All-in-One cooker beeps and starts to release pressure.

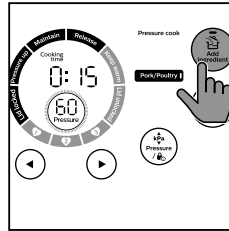

3 When pressure is released completely, the lid unlocked indicator on the cooking process indicator blinks and the All-in-One cooker beeps. You can open the top lid to add more ingredients you want.

4 Turn the handle clockwise to lock the top lid.

5 If you don't add the ingredients in two minutes, it will resume to the previous cooking process.

Multi-cooking

Saucè/Sear, Slow cook low, Slow cook high, Pot roast, Bake, Yoghurt and Reheat are multi-cooking functions.

- 1 Follow the steps in "Preparations before cooking".
- 2 Tap ◀ to choose the function you need.
 - ↳ The chosen cooking function lights up, the default cooking time is displayed on the screen.

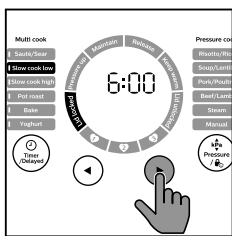

- 3 To set a different cooking time, tap Timer/Delay, Cooking time lights up.
 - ↳ The cooking time blinks.

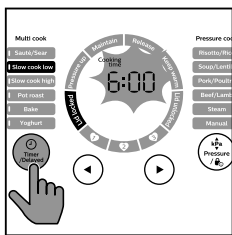

- 4 Tap ◀/▶ to set the cooking time. For the cooking time regulating range, refer to Chapter "Cooking time regulating range".

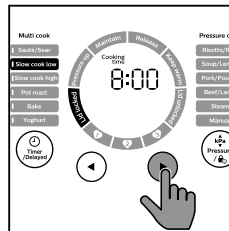

Note

- Cooking time will start to count down once internal temperature reaches cooking temperature as outlined in "Cooking time regulating range".
- There is preheat time for **Sauté/Sear** mode (up to 5 minutes). Insert your food once the **"Maintain"** status is reached on the working status ring and the timer starts to count down. Inserting food before the correct status is reached will slow down the process.
- Tap ◀ to adjust the time by hours, tap ▶ to adjust the time by minutes.

- 5 Tap and hold **Start/Reheat** for 3 seconds, the All-in-One cooker starts working in the selected mode.

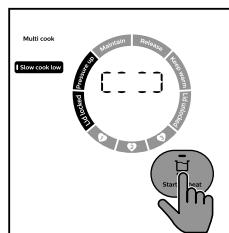

6 When the All-in One cooker reaches the cooking temperature, the cooking time starts countdown.

7 When the cooking time has elapsed, the All-in-One cooker automatically switches to keep warm mode.

↳ The Keep warm indicator on the working status ring lights up.

8 Tap **Start/Reheat** in standby mode, the All-in-One cooker will operate in reheat mode.

≡ Note

- When using the reheat function, close and lock the lid, if the pressure builds up, the cooker will automatically release steam during cooking.

Sauce thickening

≡ Note

- The Sauce thickening function applies to all cooking functions, you can use it in standby mode or keep warm mode.
- The default time is 8 minutes, you can set the time from 5 to 15 minutes.
- When the Sauce thickening function is working, tap Keep warm/Cancel to cancel.
- When using this function, keep the lid open.

1 Tap Sauce thickening button.
↳ The default cooking time is displayed.

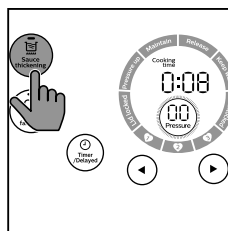

2 Tap Timer and tap ◀/▶ to set the time.

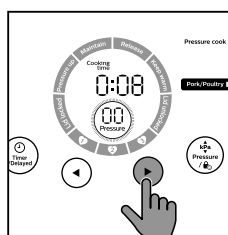

≡ Note

- When the All-in-One cooker is in warm-keeping mode, tap **Sauce thickening**, the function starts immediately.
- When the All-in-One cooker is in standby mode, firstly tap **Sauce thickening**, and then tap **Start/Reheat** for 3 seconds, the function starts immediately.

Preset time for delayed cooking

Note

- The preset timer is not available only in **Sauté/Sear, Sauce thickening** and **Reheat**.

- Follow the steps of pressure cooking or multi-cooking, choose the cooking function you need.
- Tap **Timer/Delayed** twice, the **Delay start** indicator lights up.

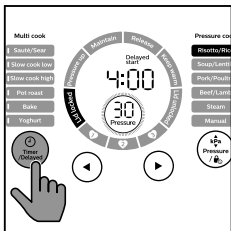

- Tap ◀/▶ to set time. Tap ◀ to adjust the time by hours, tap ▶ to adjust the time by minutes.

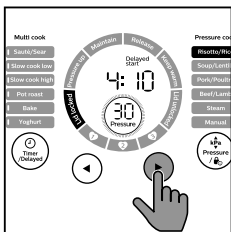

- Tap **Start/Reheat** for 3 seconds to confirm the preset time.
 - When preset time is elapsed, the All-in-One cooker starts working in the selected cooking mode automatically.

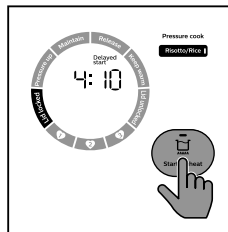

Setting up child lock

To protect your child from using the appliance, or to avoid unexpected operations during cooking, you can set up the child lock function.

- Tap and hold  for 3 seconds activate child lock.

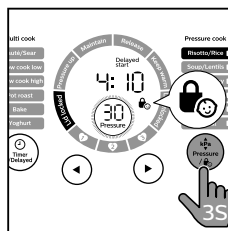

- The other buttons are not responsive.
- Tap and hold  for 3 seconds again to deactivate child lock.

Setting up My Favourite menu

You can set any three menus as "My Favourite". Before you make any changes to the setting, the default menus are "1-Risotto/Rice", "2-Soup/Lentils" and "3-Steam".

If you need to change the menu in "My Favourite", for instance to change "Soup/Lentils" to "Beef/Lamb", follow the steps below.

- 1 Tap **My Favourite** repeatedly until **2** is selected.

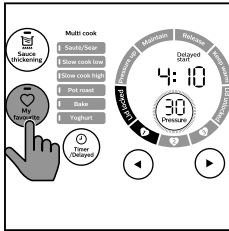

- 2 Tap **◀/▶** to select Beef/Lamb.

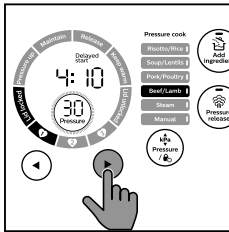

Note

- Refer to "Set the cooking time" and "Set the cooking pressure" if you need to customize the program. The new program will be saved in the "My Favourite" menu.
- If you want to save your own favourite menus, 1) first, press any No. from **1**, **2** or **3**. 2) second, select the menu you preferred from the menu list. 3) third, adjust your preferred cooking time and pressure. 4) then press and hold "My Favourite" button to save it.

- 3 Touch and hold **My Favourite** for 3 seconds, the **Soup/Lentils** will be replaced by **Beef/Lamb**.

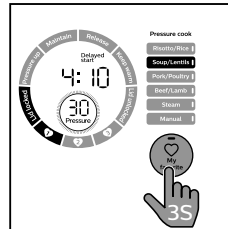

- 4 Follow steps 1-3 to change My favourite **2** or **3**.
- 5 After changing the menu, tap My Favourite once or more times to select my favourite **1**, **2** or **3** and then tap and hold Start/Reheat button to quickly access my favourite menu.

4 Cleaning and Maintenance

Note

- Unplug the All-in-One cooker before starting to clean it.
- Wait until the All-in-One cooker has cooled down sufficiently before cleaning it.

Inner lid

- Unscrew the screw around the temperature controller counter clockwise.

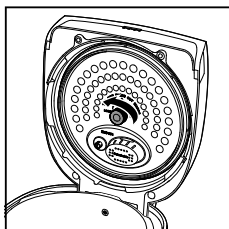

- Hold the detachable inner lid and pull it outwards to remove it from the top lid for cleaning.
- Soak in hot water and clean with sponge, or put in the dishwasher.

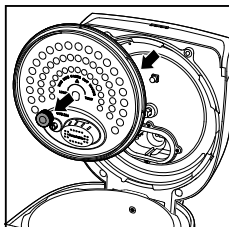

- Hold the anti-block cap and pull it outwards to remove it from the detachable inner lid for cleaning.

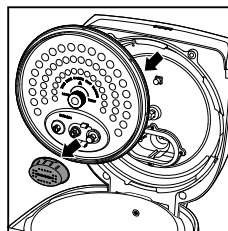

- To assemble the detachable inner lid, fully attach it to the top lid, and then screw the nut around the temperature controller clockwise.

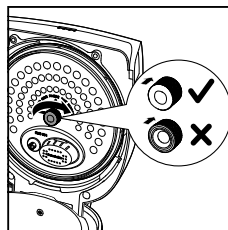

Note

- Always follow the right direction when assembling the nut.

Steam valve

- Press the recess of the steam valve and remove it from the top lid for cleaning.

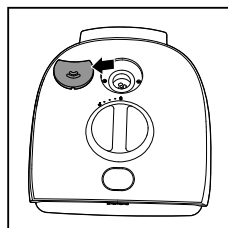

Floater

- Hold the rubber ring around the floater, and pull outwards to remove it from the top lid. Clean it regularly with water and make sure there's no food residue sticking to it, otherwise you may encounter difficulty to open the lid.

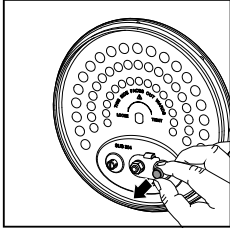

- To assemble the floater, put the thin end of the floater into the hole on the lid (fig. ①), and assemble the rubber ring around the floater (fig. ②).

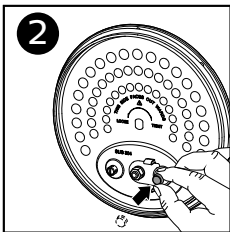
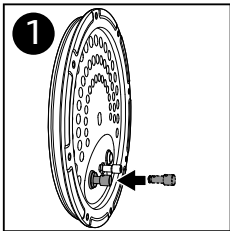

- You can also add water to the pot and start the steam function to help with the cleaning.

Pressure regulator

- Hold the handle of pressure regulator and pull it out gently. Rinse it under tap water to remove food residues inside, or use a toothpick.

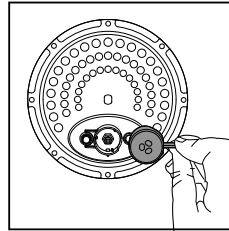

- Hold the right handle of pressure regulator and assemble it back to the inner lid.

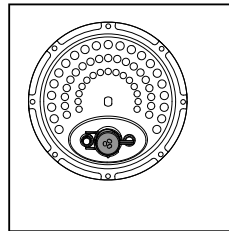

Interior

Inside of the outer lid and the main body and the heating element:

- Wipe with damp cloth.
- Make sure to remove all the food residues stuck to the All-in-One cooker.



Note

- Do not remove the sealing ring by force, it will leak if not fully assembled.

Exterior

Surface of the outer lid and outside of the main body:

- Wipe with a cloth damped with soap water.
- Only use soft and dry cloth to wipe the control panel.

Accessories and inner pot

Soup ladle and inner pot.

- Soak in hot water and clean with sponge.

5 Recycling

Do not throw away the product with the normal household waste at the end of its life, but hand it in at an official collection point for recycling. By doing this, you help to preserve the environment.

Follow your country's rules for the separate collection of electrical and electronic products. Correct disposal helps prevent negative consequences for the environment and human health.

6 Guarantee and service

If you need service or information, or if you have a problem, visit the Philips website at www.philips.com or contact the Philips Customer Care Center in your country. You can find its phone number in the worldwide guarantee leaflet. If there is no Customer Care Center in your country, go to your local Philips dealer.

7 Specifications

Model	Rated power output	Rated capacity	Diameter
HD2145	910 - 1090W	6.0 L	22 cm







Note

- Unplug the All-in-One cooker if not used for a long time.

8 Troubleshooting

If you encounter problems when using this appliance, check the following points before requesting service. If you cannot solve the problem, contact the Philips Consumer Care Center in your country.

Problem	Solution
I have difficulties closing the top lid.	<ul style="list-style-type: none">• The inner lid is not well assembled. Make sure the inner lid is well assembled around the inside of the top lid.• If the handle is in  position, turn it counter clockwise to  position, press the top lid hard to make sure it's well covered, then turn the handle back to  position.
I have difficulties opening the top lid after the pressure is released.	<ul style="list-style-type: none">• Make sure the handle is in  position.• There could be food residue on the bottom of the floating valve. Do not force to open it which may cause burn. Wait for the appliance to cool down (around 30 minutes) then repeatedly turn the handle back and forth.
The food is not cooked.	<ul style="list-style-type: none">• Incorrect function or time was selected, increase cooking time or change cooking method.• Make sure that there is no foreign residue on the heating element and the outside of the inner pot before switching the All-in-One cooker on.• The heating element is damaged, or the inner pot is deformed. Take the cooker to your Philips dealer or a service center authorized by Philips.

Problem	Solution
<p>Air or steam leaks from the lid or the steam valve.</p>	<ul style="list-style-type: none"> • The inner lid is not well assembled. Make sure the inner lid is well assembled around the inside of the top lid. • There is food residue in the sealing ring. Make sure the sealing ring is clean. • There is food residue on the floater. Clean the floater. • There is food residue in the pressure regulator. Clean the pressure regulator. • The pressure regulator is not well assembled. Make sure it's well assembled. • The cap nut around the temperature controller is loose. Fasten the cap nut tightly with the appropriate tools. • The lid is not completely closed and locked. Make sure that the lid is completely fastened and locked in the right position.
<p>The displayed pressure is higher than 70kPa.</p>	<ul style="list-style-type: none"> • The appliance is heated by a heating plate. When it reaches a preset pressure, it will stop heating. During the pressure keeping process, the temperature of the heating plate is very high, and the residual heat will continue to increase the temperature of the inner pot, so the pressure will be higher than the preset value. • When there is small water (less than 2 marks) in the pot, if the preset pressure is reached, the residual heat of the heating plate will continue to heat the inner pot for a short time. If more water is added, the displayed pressure will decrease.

Problem	Solution
<p>E1, E2, E3, E8, E10, E11, or E16 displays on the screen.</p>	<ul style="list-style-type: none"> • The All-in-One cooker has malfunction. Take the appliance to a Philips dealer or a service center authorised by Philips.
<p>The above problems still exist.</p>	<ul style="list-style-type: none"> • The All-in-One cooker has encountered a malfunction. If this is the case, please: <ol style="list-style-type: none"> (1) Do-it-yourself service. Call your local service hotline and we may be able to give instructions and help you solve the problem with video. (2) Carry-in service. Carry your product into the Philips Service Care Center. (3) Onsite service. Contact us and we'll help you arrange a Philips-authorized repair for your product, at no additional charge.



© 2020 Koninklijke Philips N.V.
All rights reserved.

HD2145_UM_Aus_v4.0

