

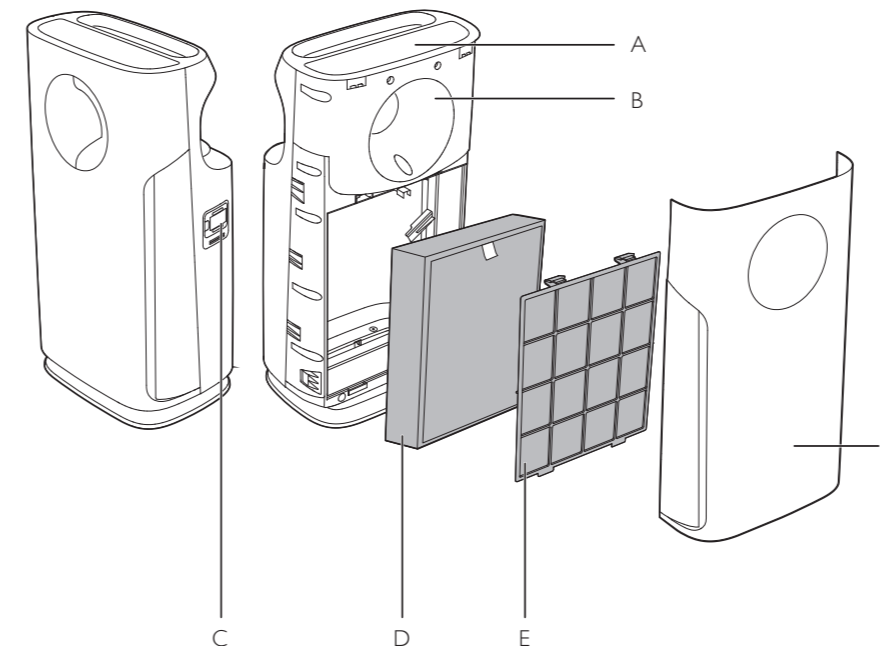

PHILIPS
AC3259



1



2

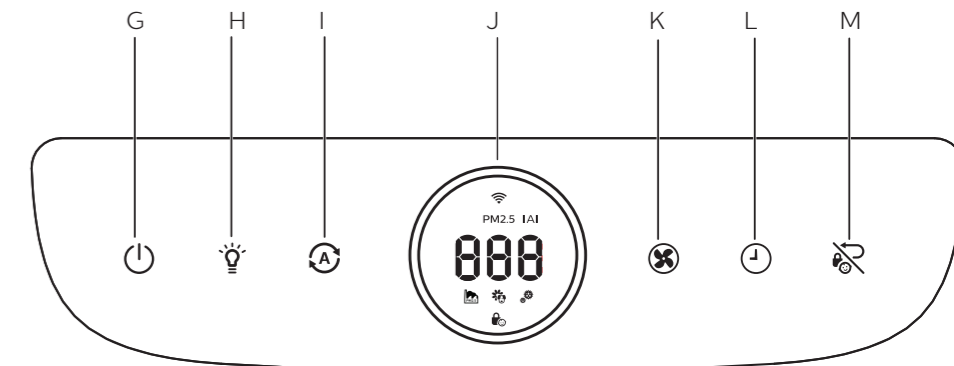

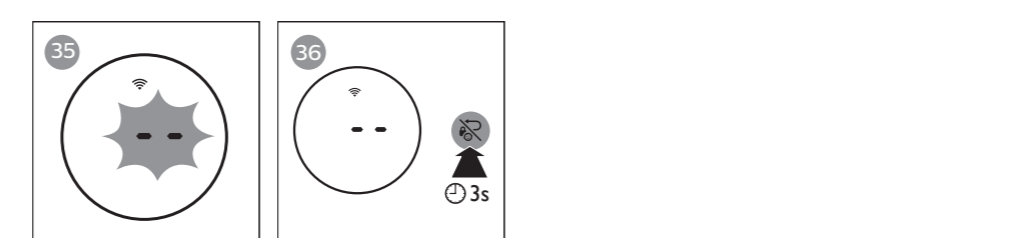
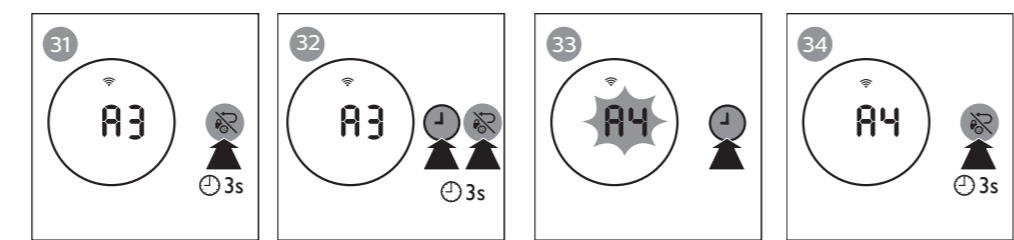
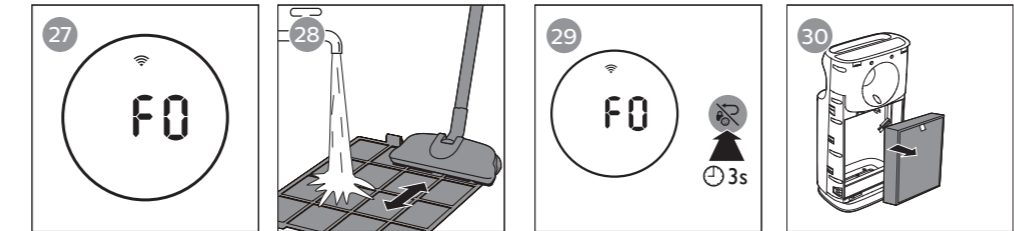
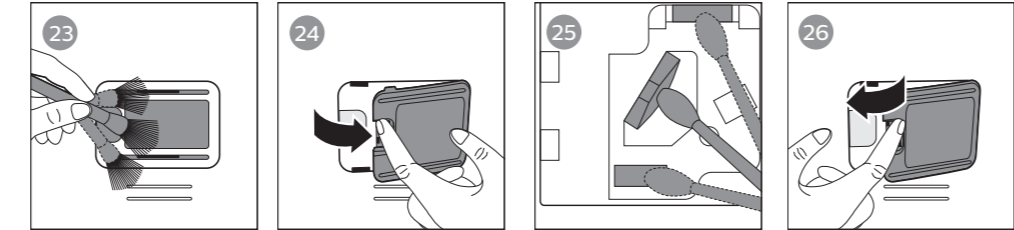
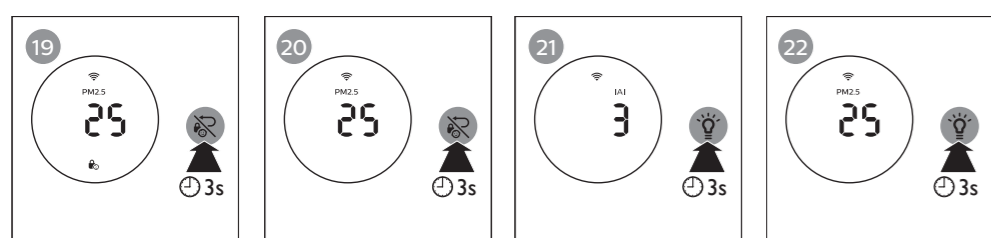
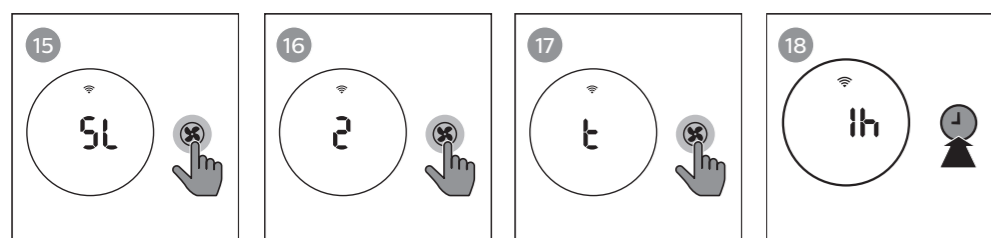
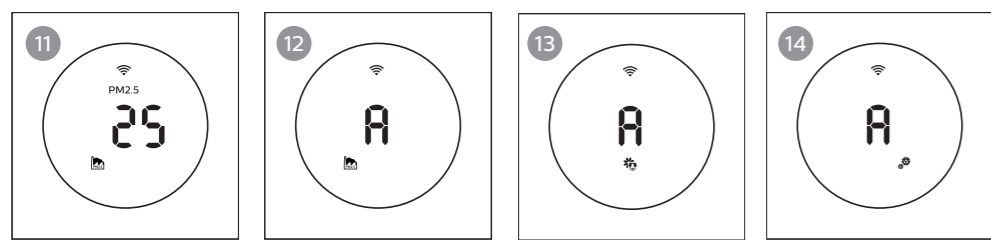
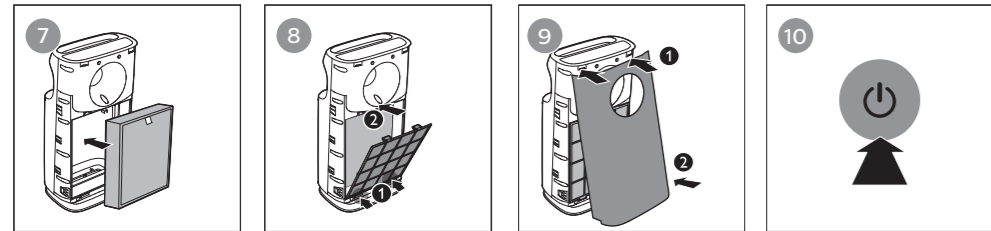
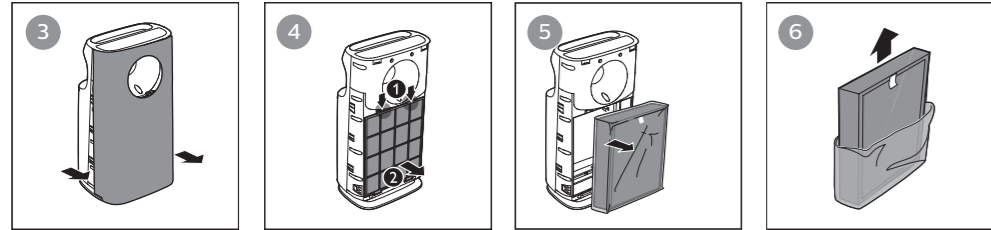

Contents

1 Important	2	6 Replacing the filter	11
Safety	2	Understanding the healthy air protect lock	11
2 Your air purifier	5	Replacing the filters	11
Product overview (fig.①)	5	Filter type change	12
Controls overview (fig.②)	5		
3 Getting started	5	7 Troubleshooting	13
Installing filters	5	8 Guarantee and service	16
Wi-Fi setup	6	Order parts or accessories	16
4 Using the appliance	7	9 Notices	16
Understanding the air quality light	7	Electromagnetic fields (EMF)	16
Switching on and off	7	Recycling	17
Changing the Auto mode setting	7	Software	17
Changing the fan speed	8		
Setting the timer	8		
Setting the child lock	8		
Using the light on/off function	9		
Switching the display mode	9		
5 Cleaning	9		
Cleaning schedule	9		
Cleaning the body of the appliance	9		
Cleaning the air quality sensor	10		
Cleaning the pre-filter	10		

Environmental friendly paper used. Thanks for your contribution to save trees.

1 Important

Safety

Read this user manual carefully before you use the appliance, and save it for future reference.

Danger

- Do not let water or any other liquid or flammable detergent enter the appliance to avoid electric shock and/or a fire hazard.
- Do not clean the appliance with water, any other liquid, or a (flammable) detergent to avoid electric shock and/or a fire hazard.
- Do not spray any flammable materials such as insecticides or fragrance around the appliance.

Warning

- Check if the voltage indicated on the appliance corresponds to the local power voltage before you connect the appliance.

- If the power cord is damaged, you must have it replaced by Philips, a service center authorized by Philips, or similarly qualified persons in order to avoid a hazard.
- Do not use the appliance if the plug, the power cord, or the appliance itself is damaged.
- This appliance can be used by children aged from 8 years and above and persons with reduced physical, sensory or mental capabilities or lack of experience and knowledge if they have been given supervision or instruction concerning use of the appliance in a safe way and understand the hazards involved. Child shall not play with the appliance. Cleaning and maintenance shall not be made by children without supervision.
- Do not block the air inlet and outlet, e.g. by placing items on the air outlet or in front of the air inlet.

- Make sure that foreign objects do not fall into the appliance through the air outlet.
- Standard WiFi interface based on 802.11b/g/n at 2.4 GHz with a maximum output power of 31.62 mW EIRP.

Caution

- This appliance is not a substitute for proper ventilation, regular vacuum cleaning, or use of an extractor hood or fan while cooking.
- If the power socket used to power the appliance has poor connections, the plug of the appliance becomes hot. Make sure that you plug the appliance into a properly connected power socket.
- Always place and use the appliance on a dry, stable, level, and horizontal surface.
- Leave at least 20cm free space behind and on both sides of the appliance and leave at least 30cm free space above the appliance.
- Do not place anything on top of the appliance.
- Do not sit or stand on the appliance. Sitting or standing on the appliance may lead to potential injury.
- Do not place the appliance directly below an air conditioner to prevent condensation from dripping onto the appliance.
- Make sure all filters are properly installed before you switch on the appliance.
- Only use the original Philips filters specially intended for this appliance. Do not use any other filters.
- Combustion of the filter may cause irreversible human hazard and/or jeopardize other lives. Do not use the filter as fuel or for similar purpose.
- Avoid knocking against the appliance (the air inlet and outlet in particular) with hard objects.

- Always lift or move the appliance by the handle on top of the appliance.
- Do not insert your fingers or objects into the air outlet or the air inlet to prevent physical injury or malfunctioning of the appliance.
- Do not use this appliance when you have used indoor smoke-type insect repellents or in places with oily residues, burning incense, or chemical fumes.
- Do not use the appliance near gas appliances, heating devices or fireplaces.
- Always unplug the appliance after use and before cleaning or carrying out other maintenance.
- Do not use the appliance in a room with major temperature changes, as this may cause condensation inside the appliance.
- To prevent interference, place the appliance at least 2 meters away from electrical appliances that use airborne radio waves such as TVs, radios, and radio-controlled clocks.
- The appliance is only intended for household use under normal operating conditions.
- Do not use the appliance in wet surroundings or in surroundings with high ambient temperatures, such as the bathroom, toilet, or kitchen.
- The appliance does not remove carbon monoxide (CO) or radon (Rn). It cannot be used as a safety device in case of accidents with combustion processes and hazardous chemicals.
- If you need to move the appliance, disconnect the appliance from the power supply first.
- Do not move the appliance by pulling its power cord.

2 Your air purifier

Congratulations on your purchase, and welcome to Philips!

To fully benefit from the support that Philips offers, register your product at www.philips.com/welcome.

Product overview (fig. ①)

- A Control panel
- B Air quality light
- C Air quality sensors
- D NanoProtect Pro S3 filter (FY3137)*
- E Pre-filter
- F Front panel

Controls overview (fig. ②)

- G On/Off button
- H Light on/off button
- I Auto mode button
- J Display screen
- K Fan speed button
- L Timer button
- M Reset/Child lock button

3 Getting started

Installing filters

Note

- Make sure the air purifier is unplugged from the electrical outlet before installing the filters.
- Make sure the side of the filter with the tag is pointing towards you.

- 1 Pull the bottom part of the front panel to remove it from the appliance (fig. ③).
- 2 Press the two clips down and pull the pre-filter towards you (fig. ④).
- 3 Remove all filters (fig. ⑤).
- 4 Remove all packaging materials of the air purification filters (fig. ⑥).
- 5 Put the unpacked air purification filters back into the appliance (fig. ⑦).
- 6 Put the pre-filter back into the appliance (fig. ⑧).

Note

- Make sure that the side with the two clips is pointing towards you, and that all hooks of the pre-filter are properly attached to the purifier.



- 7 To reattach the front panel, mount the panel onto the top of the appliance first (1). Then, gently push the panel against the body of the appliance (2) (fig. ⑨).
- 8 Wash your hands thoroughly after installing filters.

Wi-Fi setup

Setting up the Wi-Fi connection for the first time

- 1 Download and install the 'Air Matters' app from the **App Store** or **Google Play**.



- 2 Put the plug of the air purifier in the power socket and touch  to turn on the air purifier.
 - ↳ The Wi-Fi indicator  blinks orange for the first time.
- 3 Make sure that your mobile device is successfully connected to your Wi-Fi network.
- 4 Launch the 'Air Matters' app and follow the onscreen instructions to connect the air purifier to your network.
- 5 After the successful pairing and connection, the Wi-Fi indicator  will light up white. If pairing is not successful, consult the troubleshooting section, or the help section in the 'Air Matters' app for extensive and up-to-date troubleshooting tips.





Note

- This instruction is only valid when the air purifier is being set up for the first time. If the network has changed or the setup needs to be performed again, consult section "Setting up the Wi-Fi connection when the network has changed" on page 6.
- If you want to connect more than one air purifier to your smart device, you have to do this successively. Complete the set up of one air purifier before you turn on the other air purifier.
- Make sure that the distance between your mobile device and the air purifier is less than 10 m without any obstructions.
- This app supports the latest versions of Android and iOS. Please check www.philips.com/purifier-compatibility for the latest update of supported operating systems and devices.

Setting up the Wi-Fi connection when the network has changed

Note

- This applies when the default network to which your purifier is connected has changed.

- 1 Put the plug of the air purifier in the power socket and touch  to turn on the air purifier.
- 2 Touch  and  simultaneously for 3 seconds until you hear a beep.
 - ↳ The air purifier goes to pairing mode.
 - ↳ The Wi-Fi indicator  blinks orange.
- 3 Follow the steps 4-5 in "Setting up the Wi-Fi connection for the first time" section.



4 Using the appliance

Understanding the air quality light

PM2.5 level	Air quality light color	Air quality level
≤12	Blue	Good
13-35	Blue-Purple	Fair
36-55	Purple-Red	Poor
>55	Red	Very poor

The air quality light automatically goes on when the appliance is switched on, and lights up all colors in sequence. In a short time the air quality sensors select the color that corresponds to the ambient air quality.



Switching on and off

- Put the plug of the appliance in the power socket.
- Touch  to switch on the appliance (fig. 10).
 - ↳ The appliance operates under the auto mode by default.
 - ↳ After measuring the air quality for a short time, the air quality sensor automatically selects the color of the air quality light.
 - ↳ After measuring the particle matters in the air, the  icon and the PM2.5 level are displayed on the screen. (fig. 11).
- Touch and hold  for 3 seconds to switch off the appliance.

Note



- After the appliance is switched off by the on/off button , if the plug is still in the power socket, the appliance will operate under the previous settings when it is switched on again.

Changing the Auto mode setting

You can choose the Pollution mode () , the Allergen mode () and the Bacteria/Virus mode ().



Pollution mode

The specially designed pollution mode can effectively remove airborne pollutants such as PM2.5.

- Touch the Auto mode button  to select the Pollution mode (fig. 12).
 - ↳ Auto(A) and  display on the screen.



Allergen mode

The specially designed Allergen mode can effectively remove common allergens such as pollen and pet dander.



- Touch the Auto mode button  to select the Allergen mode (fig. 13).
 - ↳ Auto(A) and  display on the screen.

Bacteria/Virus mode

The specially designed Bacteria & Virus mode can effectively remove bacteria & viruses such as staphylococcus albus and H1N1.



- Touch the Auto mode button  to select the Bacteria & Virus mode (fig.14).
 - ↳ Auto(A) and  display on the screen.

Changing the fan speed

There are several fan speeds available. You can choose the sleep mode (), turbo mode() and speed 1, 2, or 3.

Sleep (SL)

In sleep mode, the appliance operates quietly under speed 1. One minute into the sleep mode, the power and light on/off indicators are dimmed, and all the other lights are off.



- Touch the fan speed button  to select the sleep mode () (fig.15).

Manual

- Touch the fan speed button  repeatedly to select the fan speed you need (fig.16).

Turbo (t)

In turbo mode, the appliance operates under the highest speed.

- Touch the fan speed button  to select the turbo mode () (fig.17).





Setting the timer

With the timer, you can let the appliance operate for a set number of hours. When the set time has elapsed, the appliance will automatically switch off.

- Touch the timer button  repeatedly to choose the number of hours you want the appliance to operate (fig.18).
 - ↳ The timer is available from 1 to 12 hours.



To deactivate the timer, touch the timer button  repeatedly until 0h displays on the screen.

Setting the child lock

- 1 Touch and hold the child lock button  for 3 seconds to activate child lock (fig.19).
 - ↳  displays on the screen.
 - ↳ When the child lock is on, all the other buttons are not responsive.
- 2 Touch and hold the child lock button  for 3 seconds again to deactivate child lock (fig.20).
 - ↳  disappears from the screen.

Using the light on/off function

With the light on/off button, you can switch on or off the air quality light, the display screen and the function indicators if needed.



- 1 Touch the light on/off button  once, the air quality light, the display screen and the function indicators will go off.
- 2 Touch the light on/off button  again, all lights will be on again.

Switching the display mode

The air purifier has two display modes: Indoor Allergen Index (IAI) display and PM2.5 display mode. When in IAI mode, the display shows a number between 1-12 to indicate the level of airborne allergens. In PM2.5 mode the display shows the particulate matter 2.5 concentration in the air in $\mu\text{g}/\text{m}^3$.

Note

- The air purifier operates in PM2.5 display mode by default.

- 1 Touch the light dimming button  for 3 seconds to switch to IAI display mode (fig. 21).
 - ↳ The actual IAI level displays on the screen.
- 2 Touch the light dimming button  for 3 seconds again to switch back to PM2.5 display mode (fig. 22).
 - ↳ The PM2.5 level displays on the screen.

5 Cleaning

Note

- Always unplug the appliance before cleaning.
- Never immerse the appliance in water or any other liquid.
- Never use abrasive, aggressive, or flammable cleaning agents such as bleach or alcohol to clean any part of the appliance.
- Only the pre-filter is washable. The air purification filter is not washable nor vacuum cleanable.

Cleaning schedule

Frequency	Cleaning method
When necessary	Wipe the surface of the appliance with a soft dry cloth
When F0 displays on the screen	Clean the pre-filter
Every two months	Clean the air quality sensors

Cleaning the body of the appliance

Regularly clean the inside and outside of the appliance to prevent dust from collecting.

- 1 Wipe away dust with a soft dry cloth from the body of the appliance.
- 2 Clean the air outlet with a soft dry cloth.

Cleaning the air quality sensor

Clean the air quality sensor every 2 months for optimal functioning of the purifier. Clean them more frequently if you use the purifier in a dusty environment.



Note

- When the humidity level in the room is very high, it is possible that condensation develops on the air quality sensor. As a result, the air quality light may indicate that the air quality is bad even though it is good. In this case you have to clean the air quality sensor or use one of the manual speed settings.

- 1 Clean the air quality sensor inlet and outlet with a soft brush (fig. 23).
- 2 Open the air quality sensor cover (fig. 24).
- 3 Clean the air quality sensor, the dust inlet and the dust outlet with a lightly moistened cotton swab (fig. 25).
- 4 Dry them with a dry cotton swab.
- 5 Reattach the air quality sensor cover (fig. 26).

Cleaning the pre-filter

Clean the pre-filter when **F0** is displayed on the screen (fig. 27).

- 1 Pull the bottom part of the front panel to remove it from the appliance (fig. 3).
- 2 Press the two clips down and pull the pre-filter towards you (fig. 4).
- 3 Wash the pre-filter under a running tap. If the pre-filter is very dirty, use a soft brush to brush away the dust (fig. 28).
- 4 Air dry the pre-filter.



Note

- Make sure that the pre-filter is completely dry. If it is still wet, bacteria may multiply in it and shorten the lifetime of the pre-filter.

- 5 Put the pre-filter back into the appliance (fig. 8).



Note

- Make sure that the side with the two clips is pointing towards you, and that all hooks of the pre-filter are properly attached to the purifier.

- 6 To reattach the front panel, mount the panel onto the top of the appliance first (1). Then, gently push the panel against the body of the appliance (2) (fig. 9).
- 7 Touch and hold the reset button  for 3 seconds to reset the pre-filter cleaning time (fig. 29).

6 Replacing the filter

Understanding the healthy air protect lock

This air purifier is equipped with a filter replacement indicator to make sure that the air purification filter is in optimal condition when the air purifier is operating. When the filters need to be replaced, the filter code displays on the screen (see **Filter alert chart**).

If the filters are not replaced in 14 days, the air purifier will stop operating and automatically lock to protect the air quality in the room. Replace the filters as soon as possible according to the filter code.

Replacing the filters

Note

- The air purification filters are not washable nor vacuum cleanable.
- Always turn off the air purifier and unplug from the electrical outlet before replacing the filters.
- Do not clean the filters with a vacuum cleaner.
- If the pre-filter is damaged, worn or broken, do not use. Visit www.philips.com/support or contact the Consumer Care Center in your country.

Filter alert chart

Filter alert light status	Follow this
A3 displays on the screen	Replace NanoProtect Pro S3 filter (FY3137)

- 1 Take out the used air filters according to the filter code displayed on the screen. Discard used filters (fig. 30).

Note





- Do not touch the pleated filter surface, or smell the filter as it has collected pollutants from the air.

- 2 Remove all packaging material of the new filters (fig. 6).
- 3 Place the new filters into the appliance (fig. 7).
- 4 Put the plug of the appliance in the wall outlet.
- 5 Touch and hold the reset button  for 3 seconds to reset the filter lifetime counter (fig. 31).

Note

- Wash your hands after changing the filters.

Filter type change

- 1 Touch  and  for 3 seconds to enter the filter type change mode (fig. 32).
 - ↳ Code (A3) of the NanoProtect filter Series 3 displays on the screen.
- 2 Touch  to select the filter code of the new filter you will use (fig. 33).
- 3 Touch and hold  for 3 seconds to confirm the filter code of the new filter (fig. 34).



Note



- After you have selected the filter code of the new filter using the  button, if you do not touch any other buttons in 10 seconds, the appliance will automatically confirm the filter code of the new filter.

- 4 "--" displays on the screen after the new filter code is confirmed (fig. 35).
 - ↳ If you do not have a second filter to use in the appliance, touch and hold  for 3 seconds to confirm and exit the filter type change mode (fig. 36).

7 Troubleshooting

This chapter summarizes the most common problems you could encounter with the appliance. If you are unable to solve the problem with the information below, contact the Consumer Care Center in your country.

Problem	Possible solution
The appliance does not work even though it is plugged in..	<ul style="list-style-type: none"> • Check if the front cover is properly installed. • The filter replacement code has been displaying on the screen but you have not replaced the corresponding filter yet. The appliance will be locked if you keep using the expired filter. In this case, replace the filter and reset the filter lifetime counter.
The appliance does not work even though it is switched on.	<ul style="list-style-type: none"> • Check if the packing materials for the filters are removed. • The appliance is working but the buttons are not responsive. Check if the child lock is on. • The filter replacement code has been on continuously but you have not replaced the corresponding filter, and the appliance is now locked. In this case, replace the filter and reset the filter lifetime counter.
The airflow that comes out of the air outlet is significantly weaker than before.	<ul style="list-style-type: none"> • The pre-filter is dirty. Clean the pre-filter (see chapter "Cleaning").
The air quality does not improve, even though the appliance has been operating for a long time.	<ul style="list-style-type: none"> • One of the filters has not been placed in the appliance. Make sure that all filters are properly installed in the following order, starting with the innermost filter: 1) NanoProtect Pro S3 filter (FY3137); 2) pre-filter • The air quality sensor is wet. The humidity level in your room is high and causes condensation. Make sure that the air quality sensor is clean and dry (see chapter "Cleaning").
The color of the air quality light always stays the same.	<ul style="list-style-type: none"> • The air quality sensor is dirty. Clean the air quality sensor (see chapter "Cleaning").

Problem	Possible solution
<p>The appliance produces a strange smell.</p>	<ul style="list-style-type: none"> • The filter may produce smell after being used for a while because of the absorption of indoor gases. It's recommended that you reactivate the filter by putting it in direct sunlight for repeated use. If odor still exists, replace the filter. • If the air purifier produces a burnt odor, switch OFF and unplug from the electrical outlet. Contact Consumer Care Center in your country.
<p>The appliance is extra loud.</p>	<ul style="list-style-type: none"> • If the appliance is too loud, you can change the fan speed to a lower fan speed level. When using the appliance in a bedroom at night, choose the sleep mode.
<p>The appliance still indicates that I need to replace a filter, but I already did.</p>	<ul style="list-style-type: none"> • Perhaps you did not reset the filter lifetime counter. Plug in the appliance, touch  to switch on the appliance, and touch and hold the reset button  for 3 seconds.
<p>Error codes "E1", or "E2" displays on the screen.</p>	<ul style="list-style-type: none"> • The appliance has malfunctions. Contact the Consumer Care Center in your country.
<p>Which App I should download?</p>	<ul style="list-style-type: none"> • Please download and install the 'Air Matters' app from the App Store or Google Play.

Problem	Possible solution
The Wi-Fi setup is not successful.	<ul style="list-style-type: none">• If the router your purifier is connected to is dual – band and currently it is not connecting to a 2.4GHz network, please switch to another band of the same router (2.4GHz) and try to pair your purifier again. 5GHz networks are not supported.• Web authentication networks are not supported.• Check if the purifier is within range of the Wi-Fi router. You can try to locate the air purifier closer to the Wi-Fi router.• Check if the network name is correct. The network name is case-sensitive.• Check if the Wi-Fi password is correct. The password is case-sensitive.• Retry the setup with the instructions in section ‘Set up the Wi-Fi connection when the network has changed’.• The Wi-Fi connectivity can be interrupted by electromagnetic or other interferences. Keep the appliance away from other electronic devices that may cause interferences.• Check if the mobile device is in airplane mode. Make sure to have the airplane mode deactivated when connecting to the Wi-Fi network.• Consult the help section in the App for extensive and up-to-date troubleshooting tips.

8 Guarantee and service

If you need information or if you have a problem, please visit the Philips website at www.philips.com or contact the Philips Consumer Care Center in your country (you find its phone number in the worldwide guarantee leaflet). If there is no Consumer Care Centre in your country, go to your local Philips dealer.

Order parts or accessories

If you have to replace a part or want to purchase an additional part, go to your Philips dealer or visit www.philips.com/support.

If you have problems obtaining the parts, please contact the Philips Consumer Care Center in your country (you can find its phone number in the worldwide guarantee leaflet).

9 Notices

Electromagnetic fields (EMF)

This Philips appliance complies with all applicable standards and regulations regarding exposure to electromagnetic fields.

Compliance with EMF

Koninklijke Philips N.V. manufactures and sells many products targeted at consumers, which, like any electronic apparatus, in general have the ability to emit and receive electromagnetic signals.

One of Philips' leading Business Principles is to take all necessary health and safety measures for our products, to comply with all applicable legal requirements and to stay well within the EMF standards applicable at the time of producing the products.

Philips is committed to develop, produce and market products that cause no adverse health effects. Philips confirms that if its products are handled properly for their intended use, they are safe to use according to scientific evidence available today.

Philips plays an active role in the development of international EMF and safety standards, enabling Philips to anticipate further developments in standardization for early integration in its products.

Recycling

Do not throw away the product with the normal household waste at the end of its life, but hand it in at an official collection point for recycling. By doing this, you help to preserve the environment.

Follow your country's rules for the separate collection of electrical and electronic products. Correct disposal helps prevent negative consequences for the environment and human health.

Software

App Store is a service mark of Apple Inc.

Google Play is a trademark of Google Inc.

This Philips appliance and Air Matters app applied multiple open source softwares, copies of open source software license text used in this product can be derived from website: www.philips.com/purifier-compatibility.



目錄

1 重要事項	20	7 疑難排解	29
安全	20		
2 您的空氣淨化器	22	8 保障及服務	31
產品簡介 (圖 ①)	22	訂購零件或配件	31
控制鍵概覽 (圖 ②)	22	9 注意	31
3 使用入門	22	電磁場 (EMF)	31
安裝過濾網	22	環保	31
Wi-Fi 設定	23	軟件	31
4 使用本產品	24		
瞭解空氣質素燈	24		
開機與關機	24		
更改自動模式設定	24		
改變風扇速度	25		
設定定時功能	25		
設定兒童安全鎖	25		
使用光源開啟/關閉功能	25		
切換顯示模式	25		
5 清潔	26		
清潔時間表	26		
清潔本產品機身	26		
清潔空氣質素感應器	26		
清潔預過濾網	27		
6 更換濾網	27		
了解清新空氣保護鎖	27		
更換過濾網	27		
濾網類型更改	28		

使用環保紙張。感謝您為保護森林作出的貢獻。

1 重要事項

安全

使用本產品前請先閱讀本用戶手冊，並保管以作將來參考。

危險事項

- 請勿讓水或任何液體或易燃清潔劑進入此產品，以避免觸電和/或火災的危險。
- 請勿用水或任何液體或（易燃）清潔劑清潔此產品，以避免觸電和/或火災的危險。
- 請勿在本產品周圍噴射殺蟲劑或芳香劑等易燃物品。

警告

- 在連接本產品前，請檢查產品註明的指示電壓與當地電源電壓是否對應。
- 如果電源軟線損壞，為避免危險，必須由製造廠或其維修部或類似的專職人員來更換。
- 若插頭、電線或產品本身已受損，請勿使用。
- 此產品可供八歲及以上兒童，體能、感官或心智能力低下人仕，或缺乏知識及經驗人仕使用，如該等人仕已就使用本產品給予監督或有關安全使用本產品的指導及明白本產品的使用所涉及的

危險。請勿讓孩童將本產品當成玩具。兒童不應於沒有監督情況下對產品進行清潔及維護。

- 請勿阻塞進氣口和排氣口，例如在排氣口上面或進氣口前面放置物件。
- 確保異物不會通過排氣口掉入裝置內部。
- 根據 2.4 GHz 802.11b/g/n，最大輸出功率 31.62 mW EIRP 的標準 WiFi 界面。

注意

- 本產品並不是適當通風設備、正規吸塵器或煮食時使用的抽油煙機或風扇的代替品。
- 若為本產品提供電力的電源插座沒有妥善連接，本產品的插頭便會發熱。請確保您已妥善連接電源插座。
- 在乾燥、穩定、平滑和水平表面上使用產品。
- 在本產品的後面和兩側至少留出 20 厘米的自由空間，本產品上方至少留出 30 厘米空間。
- 請勿在裝置上放置任何物品。
- 請勿坐或站立在裝置上。坐在或站立在裝置上可能會導致受傷。

- 請勿在冷氣機正下方放置產品，以避免冷凝滴水到產品上。
- 在開啟產品前，確保已正確安裝所有濾網。
- 僅使用專門針對本產品的原裝 Philips 濾網。請勿使用任何其他濾網。
- 燃燒過濾器可能造成無可挽救對人類的危害及/或危及他人生命。不要使用濾網作為燃料或類似用途。
- 避免以硬物碰撞產品 (尤其是產品的通風口和排氣口)。
- 請使用裝置頂部的手柄來提起或移動裝置。
- 請勿將您的手指或其他物件放入通風口或排氣口，以免造成身體傷害或產品故障。
- 若您使用室內煙型驅蚊劑，或該地方有油跡、香火或化學煙霧，請勿使用本產品。
- 請勿在煤氣用具、暖氣設備或壁爐旁邊使用本產品。
- 使用後及清潔或進行其他保養前，務必拔除本產品的插頭。
- 請勿在溫度變化較大的房間內使用本產品，這可能導致產品內產生冷凝物。
- 為了防止干擾，請與使用空中無線電波的電器如電視機、收音機及收音機鬧鐘距離 2 米的地方使用本產品。
- 本產品只適合一般操作環境下的家居使用。
- 請勿在洗手間或廚房等濕潤環境或高溫環境使用本產品。
- 本產品不會去除一氧化碳 (CO) 或氫 (Rn)。在發生燃燒過程和危險化學物質的事故中，不能將本產品作為安全裝置使用。
- 如果您需要移動本產品，請先拔除其電源供應。
- 不要拉扯電源線來移動裝置。

2 您的空氣淨化器

感謝您購買 Philips 產品，歡迎來到 Philips 世界！

要享受 Philips 為您提供的全面支援，請在以下網站 www.philips.com/welcome 註冊您的產品。

產品簡介 (圖 ①)

- A 控制面板
- B 空氣質素燈
- C 空氣質素感應器
- D NanoProtect Pro S3 濾網 (FY3137)*
- E 預過濾網
- F 前面板

控制鍵概覽 (圖 ②)

- G 開/關按鈕
- H 光源開/關按鈕
- I 自動模式按鈕
- J 顯示屏幕
- K 風扇速度按鈕
- L 定時功能按鈕
- M 重設/兒童安全鎖按鈕

3 使用入門

安裝過濾網

提示

- 安裝濾網前，請確保空氣淨化器已經從電源插座拔除。
- 確保濾網有標籤的一面是向著您。

- 1 拉出前面板的底部，將濾網從裝置中取出 (圖 ③)。
- 2 向下按兩個夾子，然後將預過濾網拉向自己 (圖 ④)。
- 3 移除所有濾網 (圖 ⑤)。
- 4 移除空氣淨化濾網的所有包裝物料 (圖 ⑥)。
- 5 將拆除包裝的空氣淨化濾網放回裝置中 (圖 ⑦)。
- 6 將預過濾網放回裝置中 (圖 ⑧)。

提示

- 確保有兩個夾的一邊正向著您，且所有預過濾網的鉤已妥善連接本產品。



- 7 要重新連接前面板塊，先將板塊固定於本產品頂部 (1)。然後輕輕將面板安裝於本產品的機身上 (2) (圖 ⑨)。
- 8 安裝濾網後，必須徹底洗淨雙手。

Wi-Fi 設定

首次設定 Wi-Fi 連線

- 1 從 App Store 或 Google Play 下載並安裝「在意空氣」應用程式。



- 2 將空氣淨化器的插頭插入電源插座，輕按  以啟動空氣淨化器。
 - ↳ Wi-Fi 指示燈  首次閃爍橙色燈光。
- 3 請確保流動裝置成功連接至 Wi-Fi 網絡。
- 4 啟動「在意空氣」應用程式，並根據畫面指示，將空氣淨化器連接至您的網絡。
- 5 成功配對並連接後，Wi-Fi 指示燈  便會閃爍白色燈光。如未能成功配對，請參閱疑難排解部分，或「在意空氣」應用程式中的說明部分，以獲取最新的詳細疑難排解貼士。





提示

- 本指示僅適用於首次設定空氣淨化器。如網絡有變或需要重新設定，請參閱第 23 頁的「網絡改變後設定 Wi-Fi 連線」部分。
- 如您要將多於一部空氣淨化器連接至智能裝置，您必須逐一連接。啟動另一部空氣淨化器前，請完成設定當前的空氣淨化器。
- 請確保流動裝置和空氣淨化器的距離在 10 米以內，而且沒有任何障礙物。
- 本應用程式支援最新版本的 Android 和 iOS。請查閱 www.philips.com/purifier-compatibility，以了解支援的作業系統和裝置的最新資料。

網絡改變後設定 Wi-Fi 連線

提示

- 本提示只在空氣淨化器已連接的預設網絡改變時適用。

- 1 將空氣淨化器的插頭插入電源插座，輕按  以啟動空氣淨化器。
- 2 同時按下  和  3 秒，直至聽到「嗶」聲為止。
 - ↳ 空氣淨化器進入配對模式。
 - ↳ Wi-Fi 指示燈  閃爍橙色燈光。
- 3 請按照「首次設定 Wi-Fi 連線」部分的步驟 4-5 操作。



4 使用本產品

瞭解空氣質素燈

PM2.5 水平	空氣質素指示燈的顏色	空氣質素水平
≤12	藍色	良好
13-35	藍紫色	一般
36-55	紫紅色	差
>55	紅色	非常差

開啟產品時，空氣質素燈將自動亮起，並順序顯示所有顏色。片刻之後，空氣質素感應器將選擇與環境空氣質素相符的顏色。



開機與關機

- 1 將產品的插頭插入電源插座。
- 2 點按  開啟裝置 (圖 10)。
 - ↳ 裝置默認以自動模式運行。
 - ↳ 快速測量空氣質素後，空氣質素感應器將自動選擇適當的空氣質素燈的顏色。
 - ↳ 測量空氣中的粒子質素後，螢幕上會顯示  圖示和 PM2.5 水平。(圖 11)。
- 3 按住  3 秒關閉產品。

提示



- 透過開/關按鈕關閉本產品後， 如果插頭仍插在電源插座中，則再次開啟本產品時，本產品將根據上一次的設定恢復工作。

更改自動模式設定

您可以選擇過濾污染模式 ()、過濾致敏原模式 () 及過濾細菌/病毒模式 ()。



過濾污染模式

特別設計的過濾污染模式可以有效消除空氣中的污染物，如 PM2.5。

- 點按自動模式按鈕 ，選擇過濾污染模式 (圖 12)。
 - ↳ Auto (自動) (A) 及  將會顯示在螢幕上。



過濾致敏原模式

特別設計的過濾致敏原模式能有效去除常見的過敏原，如花粉及寵物毛屑。

- 點按自動模式按鈕 ，選擇過濾致敏原模式 (圖 13)。
 - ↳ Auto (自動) (A) 及  將會顯示在螢幕上。

過濾細菌/病毒模式

特別設計的過濾細菌/病毒模式可以有效去除細菌和病毒，如表皮葡萄球菌和 H1N1 流感病毒。

- 點按自動模式按鈕 ，選擇過濾細菌/病毒模式 (圖 14)。
 - ↳ Auto (自動) (A) 及  將會顯示在螢幕上。

改變風扇速度

設有多個風扇速度 您可以選擇休眠模式（SL）、加速模式（t）及速度 1、2 或 3 的設定。

休眠模式 (SL)

在休眠模式中，產品會安靜地運行速度 1。進入睡眠模式一分鐘後，電源和開/關指示燈會變暗，其他所有燈都會熄滅。

- 按下風扇速度按鈕  以選擇休眠模式（SL）（圖 15）。

手動模式

- 重複按下風扇速度按鈕  以選擇您所需的風扇速度（圖 16）。

加速模式 (t)



在加速模式中，產品會以最高的速度運行。

- 按下風扇速度按鈕  以選擇加速模式（t）（圖 17）。





設定定時功能

透過定時功能，您可以讓本產品在設定時間內運作。設定時間過去之後，本產品便會自動關閉。

- 重複按定時按鈕  選擇本產品運作的小時數（圖 18）。
 - 定時功能的選擇為 1 至 12 小時。



要取消計時功能，重複按下定時按鈕 ，直至  顯示在螢幕上。

設定兒童安全鎖

- 按住兒童安全鎖按鈕  3 秒，以啟動兒童安全鎖（圖 19）。
 -  將會顯示在螢幕上。
 - 當兒童安全鎖處於開啟狀態時，所有其他按鈕均不響應。
- 再次按住兒童安全鎖按鈕  3 秒，關閉兒童安全鎖（圖 20）。
 -  將會從屏幕消失。

使用光源開啟/關閉功能

透過光源開啟/關閉按鈕，您可以開啟或關閉空氣質素燈、顯示畫面及功能指示燈。



- 輕按一下光源開啟/關閉按鈕 ，即可關閉空氣質素燈、顯示畫面及功能指示燈。
- 再次按下光源開啟/關閉按鈕 ，所有燈將會再次亮起。

切換顯示模式

空氣淨化器設有兩種顯示模式：室內致敏原指數（IAI）顯示和 PM2.5 顯示模式。室內致敏原指數模式以數字 1-12 顯示空氣中致敏原的水平。PM2.5 模式顯示空氣內的 PM2.5 懸浮微粒濃度（單位為 $\mu\text{g}/\text{m}^3$ ）。

提示

- 空氣淨化器默認以 PM2.5 顯示模式運行。

- 按下調暗燈光按鈕  3 秒，以切換至室內致敏原指數（IAI）顯示模式（圖 21）。
 - 螢幕顯示實際的室內致敏原指數。
- 再次按下調暗燈光按鈕  3 秒，以重新切換至 PM2.5 顯示模式（圖 22）。
 - 螢幕顯示 PM2.5 水平。

5 清潔

提示

- 每次清潔前請拔出裝置電源。
- 絕不將本產品侵入水中或任何其他液體中。
- 請勿使用磨蝕性、侵略性或易燃清潔劑（如漂白劑或酒精）清洗本產品的任何一部分。
- 只有預過濾網是可清洗的。請勿清洗空氣淨化器濾網，也切勿使用吸塵機清潔。

清潔時間表

頻率	清潔方法
必要時	用柔軟的乾布抹乾淨本產品表面
當 FO 顯示在螢幕上時	清洗預過濾網
每兩個月	清潔空氣質素感應器

清潔本產品機身

請定時清潔本產品的內外，以避免本體內積聚塵埃。

- 1 使用柔軟的乾布擦掉本體內的塵埃。
- 2 使用柔軟的乾布清潔排氣口。

清潔空氣質素感應器

每兩個月清潔空氣質素感應器，讓本產品發揮出最佳功能。若在多塵的地方使用本淨化器，請更頻密清潔。

提示

- 若房間內的濕度水平很高，空氣質素感應器上可能會凝結水滴。因此，即使空氣質素良好，空氣質素燈可能會顯示空氣質素為差。在此情況下，您必須清潔空氣質素感應器或使用其中一個手動設定。

- 1 使用柔軟毛刷清潔空氣質素感應器進氣口及排氣口（圖 23）。
- 2 打開空氣質素感應器護蓋（圖 24）。
- 3 使用稍為濕潤的棉花棒清潔空氣質素感應器和塵埃的出入口（圖 25）。
- 4 再以乾爽的棉花棒刷乾。
- 5 重新裝上空氣質量感應器護蓋（圖 26）。

清潔預過濾網

當螢幕顯示 FO 時，請清潔預過濾網（圖 27）。

- 1 拉出前面板的底部，將濾網從裝置中取出（圖 3）。
- 2 向下按兩個夾子，然後將預過濾網拉向自己（圖 4）。
- 3 以自來水清洗預過濾網。如果預過濾網內部十分骯髒，可用軟刷將塵埃刷走（圖 28）。
- 4 吹乾預過濾網

提示

- 請確保預過濾網完全乾透。如果預過濾網仍是濕的，細菌可能會滋生，縮短預過濾網的壽命。

- 5 將預過濾網放回本產品內（圖 8）。

提示

- 確保有兩個夾的一邊正向著您，且所有預過濾網的鉤已妥善連接本產品。

- 6 要重新連接前面板塊，先將板塊固定於本產品頂部 (1)。然後輕輕將面板安裝於本產品的機身上 (2)（圖 9）。
- 7 按住重設按鈕  3 秒以重新設定預過濾網清潔時間（圖 29）。

6 更換濾網

了解清新空氣保護鎖

空氣淨化器設有過濾網替換指示燈，以確保空氣淨化濾網在空氣淨化器運作時處於良好狀態。需要更換濾網時，螢幕會顯示濾網代碼（請參閱 濾網警示表）。

如果 14 天內不更換濾網，空氣淨化器將會停止運作並自動鎖上，以保障室內空氣質素。根據濾網代碼指示，盡快更換過濾網。

更換過濾網

提示

- 請勿清洗空氣淨化器濾網，也切勿使用吸塵機清潔。
- 更換濾網前，必須關閉空氣淨化器，並將其從電源插座拔除。
- 請勿以吸塵機清潔濾網。
- 請勿使用已損壞的預過濾網。請瀏覽 www.philips.com/support 或聯絡你所在國家/地區的客戶服務中心。

濾網警示表

過濾網警示燈狀態	按照此步驟進行操作
當 A3 顯示在螢幕上時	更換 NanoProtect Pro S3 濾網 (FY3137)

- 1 根據螢幕上顯示的濾網代碼，取出舊的空氣濾網。棄置舊的濾網（圖 30）。

提示





- 請勿觸摸折疊的過濾網表面，或去聞過濾網上的氣味，因為過濾網上聚集了空氣中的污染物。

- 2 拆去新過濾網上的所有包裝物料 (圖 6)。
- 3 將新濾網放入裝置 (圖 7)。
- 4 將裝置的插頭插入牆身插座。
- 5 按住重設按鈕 3 秒以重新設定濾網使用時間。(圖 31)。

提示

- 更換濾網後，必須洗手。

濾網類型更改

- 1 同時按下  及  3 秒，進入濾網類型更改模式 (圖 32)。
 - ↳ NanoProtect 濾網 Series 3 的代碼 (A3) 將會顯示在螢幕上。
- 2 按下  以選擇要使用的新濾網的濾網代碼 (圖 33)。
- 3 按住  3 秒以確定新濾網的濾網代碼 (圖 34)。



提示

- 使用  按鈕選擇新濾網的濾網代碼後，如果 10 秒內沒有按下其他任何按鈕，裝置將自動確認新濾網的濾網代碼。

- 4 確定新的濾網代碼後，螢幕便會顯示「--」(圖 35)。
 - ↳ 如裝置內沒有可用的第二個濾網，請按住  3 秒以確認並離開濾網類型更改模式 (圖 36)。

7 疑難排解

本章節總結一些您在本產品上最常見的問題。如果您按照以下資料仍未能解決問題，請聯絡您的國家的 Philips 顧客服務中心。

問題	可行解決方案
產品即使插上電源也沒有正常運作。	<ul style="list-style-type: none"> 請檢查前蓋是否已穩妥安裝好。 濾網替換代碼已經顯示在螢幕上，但您還沒有作出相應的濾網替換動作。如果你持續使用過期的濾網，裝置將會鎖上。在這情況，請更換該濾網並重設濾網使用時間。
產品即使啟動了也沒有正常運作。	<ul style="list-style-type: none"> 請檢查濾網的包裝物料是否已經移除。 產品正在運作，但按鈕無響應。請查看兒童安全鎖是否有開啟。 濾網替換代碼持續亮起，但你沒有作出相應的濾網替換動作，裝置已經鎖上。在這情況，請更換該濾網並重設濾網使用時間。
從排氣口排出的氣流比以前顯著減弱。	<ul style="list-style-type: none"> 預過濾網處於骯髒的狀態。清潔預過濾網（請查看「清潔」一章）。
即使本產品工作很久，空氣質素也沒有改善。	<ul style="list-style-type: none"> 本產品的一個濾網沒有得到更換。請確認所有過濾網均按正確次序裝上，由內至外為： <ol style="list-style-type: none"> 1) NanoProtect Pro S3 濾網 (FY3137)； 2) 預過濾網 空氣質量感測器變濕。您的房間濕度高，導致水分凝結。確保空氣質量感應器清潔和保持乾燥（請參閱「清潔」一章）。
空氣質素光環的顏色永遠保持同一顏色。	<ul style="list-style-type: none"> 空氣質量感測器處於骯髒的狀態。清潔空氣質素感應器（請參閱「清潔」一章）。
本產品發出一陣怪味。	<ul style="list-style-type: none"> 由於吸收了室內氣體，濾網使用一段時間後可能會產生氣味。建議您將濾網置於陽光下，然後再重新使用。如果仍有異味，請更換濾網。 如空氣淨化器產生燒焦的氣味，請「關閉」電源，並將插頭從電源插座拔出。請聯絡你所在國家/地區的客戶服務中心。
本產品噪音特別大。	<ul style="list-style-type: none"> 如果產品太吵，可調低風扇速度。如晚上在睡房使用裝置，選擇睡眠模式。
產品仍然指示我需要更換濾網，但是我已經更換。	<ul style="list-style-type: none"> 可能你沒有重置濾網的使用時間。插入產品插頭，按  按鈕開啟並按住重設按鈕  3 秒。

問題	可行解決方案
螢幕將會顯示「E1」或「E2」錯誤代碼。	<ul style="list-style-type: none"> 裝置發生故障。請聯絡你所在國家/地區的客戶服務中心。
我應該下載哪一個應用程式？	<ul style="list-style-type: none"> 請從 App Store 或 Google Play 下載並安裝「在意空氣」應用程式。
未能成功設定 Wi-Fi。	<ul style="list-style-type: none"> 如空氣淨化器連接至雙頻寬路由器，而現時並非連接至 2.4GHz 網絡，請切換至同一路由器的另一頻寬（2.4GHz），然後再嘗試配對空氣淨化器。裝置不支援 5GHz 網絡。 裝置不支援網上驗證網絡。 請檢查空氣淨化器是否在 Wi-Fi 路由器的有效範圍以內。您可以嘗試將空氣淨化器移近 Wi-Fi 路由器。 請檢查網絡名稱是否正確。網絡名稱有大小寫之分。 請檢查 Wi-Fi 密碼是否正確。密碼有大小寫之分。 根據「網絡改變後設定 Wi-Fi 連線」部分的指示，嘗試重新設定。 產品的 Wi-Fi 連接可能被電磁場或其他干擾中斷。將裝置遠離可能會造成干擾的其他電子設備。 請檢查流動裝置是否處於飛行模式。連接至 Wi-Fi 網絡時，請確保停用飛行模式。 請參閱應用程式中的說明部分，以獲取最新的詳細疑難排解貼士。

8 保障及服務

如果您需要資料或有疑問，請前往 Philips 網站 www.philips.com 或聯絡您的國家的 Philips 顧客服務中心（您會在全球保障小冊子上找到其電話號碼）。如果您的國家沒有顧客服務中心，請前往當地的 Philips 經銷商。

訂購零件或配件

如果您需要更換零件或想訂購額外配件，請前往您的 Philips 經銷商或瀏覽 www.philips.com/support。

如果您索取有關零件時遇上問題，請聯絡您的國家/地區 Philips 顧客服務中心（您可在全球保障小冊子上找到其電話號碼）。

9 注意

電磁場（EMF）

這款 Philips 產品符合一切有關電磁場暴露的適用安全標準及條例。

符合 EMF 標準

Koninklijke Philips N.V. 專為消費者製造及銷售許多產品（例如任何電器用品），而這些產品都能發出與接收電磁訊號。

Philips 貫徹執行的一項主要商業準則是對我們的產品採取所有必要的健康和安全措施，遵循一切可行的法律規定，並在產品生產期間嚴格遵守 EMF 標準。

Philips 致力於開發、生產及銷售對健康無害的產品。Philips 確認如果產品在目標用途中操作得當，根據當今權威科學論證，將不會存在任何安全隱患。

Philips 在開發國際 EMF 和安全標準中扮演著積極作用，有助其預見未來標準化的發展趨勢以便盡早融入至產品中。

環保

請勿在本產品使用壽命結束後當作一般家庭垃圾廢棄，應交給官方回收站作循環再用。這樣做有助保護環境。

請遵守您的國家/地區回收電器和電子產品的法則。正確處理廢棄產品有助避免對環境和人體造成負面影響。

軟件

App Store 是 Apple Inc. 的服務標誌

Google Play 是 Google Inc. 的商標

本 Philips 裝置及在意空氣應用程式使用多個開放源碼軟件，本產品使用的開放源碼軟件許可證文本可以由

www.philips.com/purifier-compatibility 網站取得。

