

PHILIPS

GC628, GC629



EN User manual

KO 사용 설명서

MS Manual pengguna

TH คู่มือผู้ใช้

VI Hướng dẫn sử dụng

SC 用户手册

TC 使用手冊

	3		22
	7		23
	8		25
	10		26
	13		28
	15		29
	18		29
	20		30
	20		55
	21		

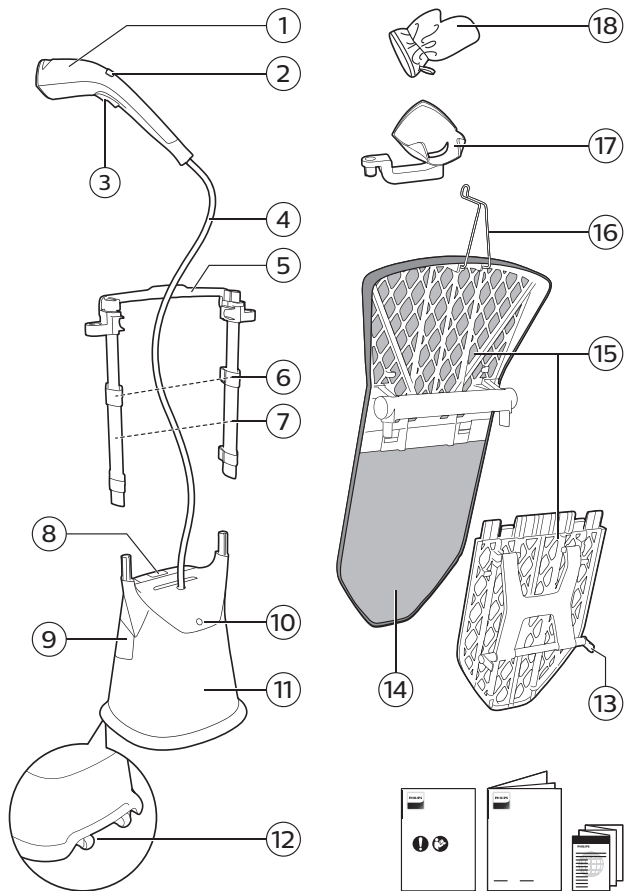

EN

- ① Steamer head
- ② Steam selection
- ③ Steam trigger
- ④ Steam supply hose
- ⑤ Board tilting lever
- ⑥ Pole lock clip
- ⑦ Poles
- ⑧ Water tank release lock
- ⑨ Water tank
- ⑩ Power button
- ⑪ Base
- ⑫ Wheels
- ⑬ Board lock
- ⑭ Board cover
- ⑮ Board
- ⑯ Hanger hook
- ⑰ Side docking
- ⑱ Glove

KO

- ① 스티머 헤드
- ② 스팀 선택
- ③ 스팀 버튼
- ④ 스팀호스
- ⑤ 다림판 기울기 레버
- ⑥ 폴 잠금 클립
- ⑦ 폴
- ⑧ 물탱크 잠금 장치
- ⑨ 물탱크
- ⑩ 전원 버튼
- ⑪ 받침대
- ⑫ 바퀴
- ⑬ 다림판 잠금
- ⑭ 다림판 덮개
- ⑮ 다림판
- ⑯ 옷걸이
- ⑰ 측면 도크
- ⑱ 장갑

MS

- | | |
|----------------------------|-----------------------|
| ① Kepala penstim | ⑩ Butang kuasa |
| ② Pilihan stim | ⑪ Tapak |
| ③ Picu stim | ⑫ Roda |
| ④ Hos bekalan stim | ⑬ Kunci papan |
| ⑤ Tuil pencondong papan | ⑭ Alas papan |
| ⑥ Klip pengunci dirian | ⑮ Papan |
| ⑦ Dirian | ⑯ Cangkuk penggantung |
| ⑧ Kunci pelepas tangki air | ⑰ Dok sisi |
| ⑨ Tangki air | ⑱ Sarung tangan |

TH

- | | |
|-----------------------------------|---------------------|
| ① หัวพ่นไอน้ำ | ⑩ ปุ่มเปิด/ปิด |
| ② การเลือกไอน้ำ | ⑪ ลู่วาน |
| ③ ปุ่มใช้พลังไอน้ำ | ⑫ ล้อ |
| ④ สายไอน้ำ | ⑬ ตัวล็อคโต๊ะรองรีด |
| ⑤ คันโยกปรับความเอียง | ⑭ ผ้ารองรีด |
| ⑥ คลิปล็อคเสา | ⑮ โต๊ะรองรีด |
| ⑦ เสา | ⑯ ตะขอที่แขวน |
| ⑧ ตัวล็อคการปล่อยน้ำออกจากแท่งค้ำ | ⑰ แท่นด้านข้าง |
| ⑨ แท่งค้ำน้ำ | ⑱ ถุงมือ |

VI

- | | |
|----------------------------|-----------------|
| ① Đầu bàn ủi hơi nước | ⑩ Nút nguồn |
| ② Núm chọn chế độ hơi nước | ⑪ Đê |
| ③ Núm bấm hơi phun | ⑫ Bánh xe |
| ④ Ống cấp hơi phun | ⑬ Khóa ván ủi |
| ⑤ Chốt lật nghiêng ván ủi | ⑭ Vỏ bọc ván ủi |
| ⑥ Kẹp khóa | ⑮ Ván ủi |
| ⑦ Trụ | ⑯ Móc treo |
| ⑧ Khóa tháo ngăn chứa nước | ⑰ Đê dụng bên |
| ⑨ Ngăn chứa nước | ⑱ Găng tay |

SC

- | | |
|----------|----------|
| ① 蒸汽喷头 | ⑩ 电源开关 |
| ② 蒸汽选择按键 | ⑪ 底座 |
| ③ 蒸汽开关 | ⑫ 滚轮 |
| ④ 蒸汽输送管 | ⑬ 熨衣板锁 |
| ⑤ 可倾斜杆 | ⑭ 熨衣板罩 |
| ⑥ 伸缩杆锁夹 | ⑮ 熨衣板 |
| ⑦ 伸缩杆 | ⑯ 衣架钩 |
| ⑧ 水箱按键 | ⑰ 侧面喷头支架 |
| ⑨ 水箱 | ⑱ 防烫手套 |

TC

- | | |
|-----------|--------|
| ① 蒸氣噴頭 | ⑩ 電源按鈕 |
| ② 蒸氣選擇 | ⑪ 底座 |
| ③ 蒸氣觸動器 | ⑫ 輪子 |
| ④ 蒸氣膠管 | ⑬ 熨燙板鎖 |
| ⑤ 熨燙板傾斜壓桿 | ⑭ 熨燙板套 |
| ⑥ 掛桿鎖固定夾 | ⑮ 熨燙板 |
| ⑦ 掛桿 | ⑯ 衣架掛鈎 |
| ⑧ 水箱釋放鎖 | ⑰ 側基座 |
| ⑨ 水箱 | ⑱ 手套 |

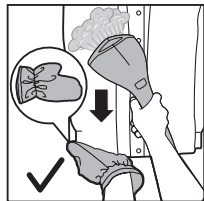
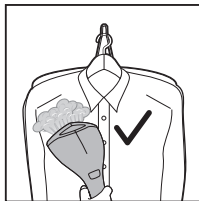
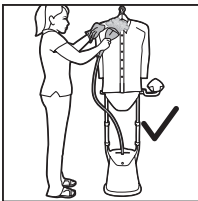
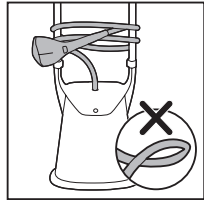
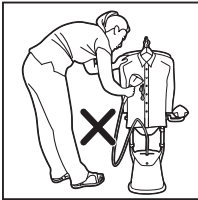
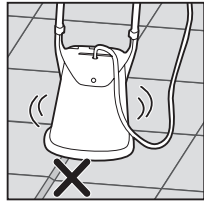
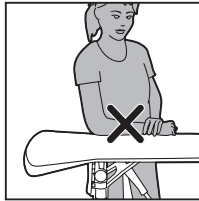
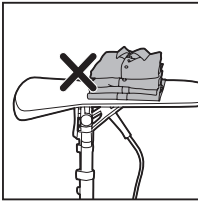
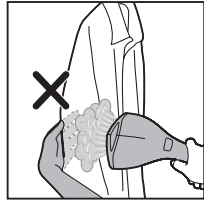

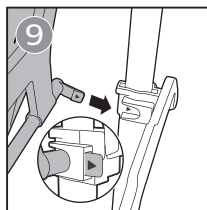
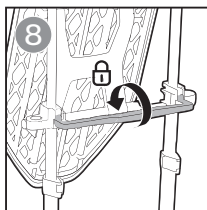
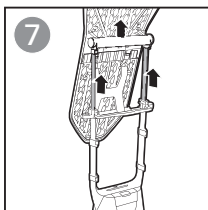
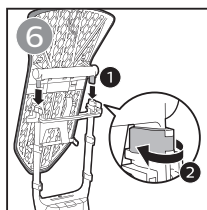
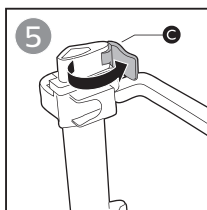
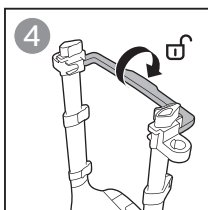
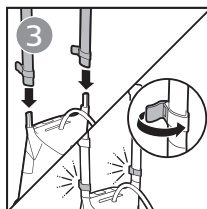
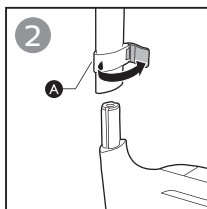
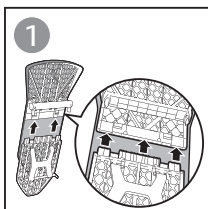
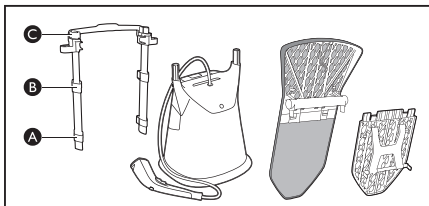

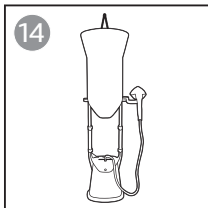
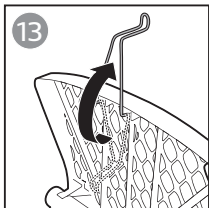
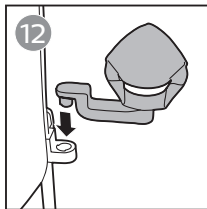
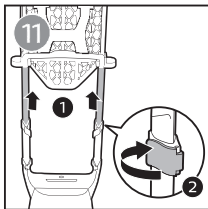
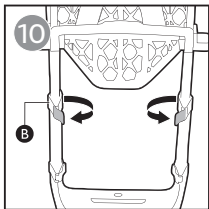

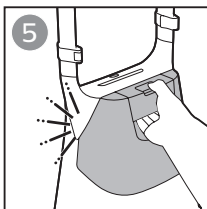
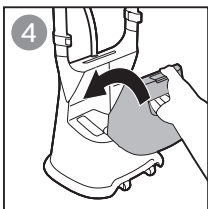
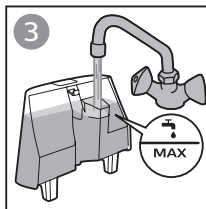
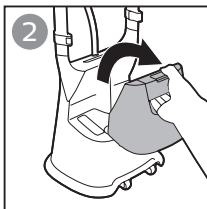
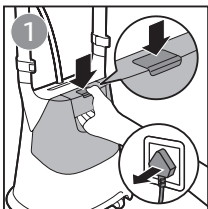
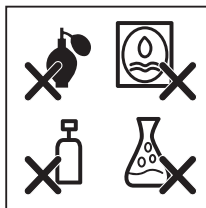
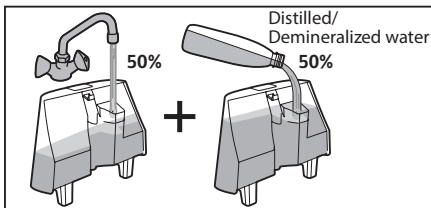

EN Type of water to use

The appliance is suitable to be used with tap water. However, if you live in an area with hard water, we recommend that you mix an equal amount of tap water with distilled or demineralized water. This will prevent fast scale build up and prolong the lifetime of the appliance.

Warning: Do not use perfumed water, water from the tumble dryer, vinegar, starch, descaling agents, ironing aids, chemically descaled water or other

chemicals, as they may cause water spitting, brown staining or damage to your appliance.

Note: Do not fill the water tank beyond the **MAX** indication.

KO 사용할 물의 종류

이 제품은 수도물을 사용하는 것이 적합합니다. 그러나 경수가 있는 지역에서 사는 경우 증류수 또는 탈염수를 같은 양의 수도물과 혼합하여 사용할 것을 권장합니다. 이렇게 하면 석회질이 빠르게 쌓이지 않고 제품의 수명이 연장됩니다.

경고: 향수, 회전식 건조기의 물, 식초, 풀, 석회질 제거제, 다림질 보조제, 이물질 제거용 화학 약품이나 기타 화학 용품을 넣지 마십시오. 물이 튀거나 갈색 얼룩이 생기거나 제품이 손상될 수 있습니다.

참고: 물탱크는 최대 수위량인 **MAX** 표시선 이상 채우지 마십시오.

MS Jenis air untuk digunakan

Perkakas sesuai untuk digunakan dengan air paip. Walau bagaimanapun, jika anda tinggal di kawasan dengan air liat, kami menasihatkan agar anda mencampurkan air paip dengan air suling atau air tanpa mineral dalam jumlah yang sama. Langkah ini akan menghalang pembentukan karat yang cepat dan memanjangkan hayat perkakas anda.

Amaran: Jangan gunakan air berwangian, air dari mesin pengering pakaian, cuka, kanji, agen penyahkerak, bahan bantu penyeterikaan, air dinyahkerak secara kimia atau bahan kimia lain, kerana ini boleh menyebabkan air berdetus, kesan kotoran berwarna perang atau kerosakan pada perkakas anda.

Nota: Jangan isi tangki air melebihi penanda **MAX**.

TH ชนิดของน้ำที่ใช้งาน

เครื่องเหมาะสำหรับใช้งานกับน้ำประปา อย่างไรก็ตามหากคุณอาศัยอยู่ในพื้นที่ที่น้ำกระด้างมาก เราขอแนะนำให้คุณผสมน้ำประปาในปริมาณที่เท่ากับน้ำกลั่นหรือน้ำปราศจากไอออน วิธีนี้จะช่วยป้องกันการเกิดตะกอนอย่างรวดเร็วและยืดอายุการใช้งานของเครื่อง

คำเตือน: ห้ามใช้น้ำหอม น้ำจากเครื่องอบผ้า น้ำส้มสายชู แป้ง น้ำยาขจัดคราบตะกอน ผลิตภัณฑ์สำหรับการรีดผ้า น้ำที่ขจัดคราบตะกอนด้วยวิธีการทางเคมี หรือสารเคมีอื่นๆ เนื่องจากอาจทำให้น้ำกระด้าง เกิดคราบสีน้ำตาล หรือทำให้เครื่องเสียหายได้

หมายเหตุ: ไม่ควรเติมน้ำในถังเกินระดับ **MAX** (สูงสุด) ที่ระบุ

VI Loại nước được sử dụng

Thiết bị thích hợp để sử dụng với nước máy. Tuy nhiên, nếu bạn sống ở khu vực có nước cứng, chúng tôi khuyên bạn nên hòa chung một lượng nước máy vừa đủ với nước cất hoặc nước đã khử khoáng. Việc này sẽ giúp ngăn tích tụ cặn nhanh và kéo dài tuổi thọ của thiết bị.

Cảnh báo: Không thêm nước hoa, nước từ máy sấy đảo, giấm, hồ vôi, chất làm sạch cặn, chất phụ trợ ùi, nước đã được tẩy sạch bằng hóa chất hoặc các hóa chất khác, do các chất này có thể gây tình trạng phun nước, ô vàng hoặc làm hỏng thiết bị của bạn.

Lưu ý: Không châm nước vào ngăn chứa nước vượt quá chỉ báo **MAX (Tối đa)**.

SC 所用水质类型

本产品可使用自来水。但如果您居住的区域水质硬，我们建议您将等量的自来水与蒸馏水或软化水混合使用。这样可以防止水垢快速积聚，并且可以延长产品的使用寿命。

警告：切勿使用香水、转筒式干燥机中的水、醋、淀粉、除垢剂、熨衣剂、化学除垢水或其他化学品，因为它们可能会导致喷水、留下褐色污垢或损坏产品。

注意：请勿让水位超过 **MAX (最多)** 水位标示。

TC 使用的水質

本產品適合搭配自來水使用。不過，如果您居住地區的水質偏硬，建議您將等量的自來水與蒸餾水或軟化水混合。如此可避免快速累積水垢，並延長產品的使用壽命。

警告：請勿使用香水、滾筒式烘乾機的水、醋、燙衣漿、除垢劑、燙燙添加劑、經化學除垢的水或其他化學物質，否則可能造成水噴濺溢漏、產生棕色汙漬或損壞產品。

備註：加水時不可超過水箱中的 **MAX** 刻度

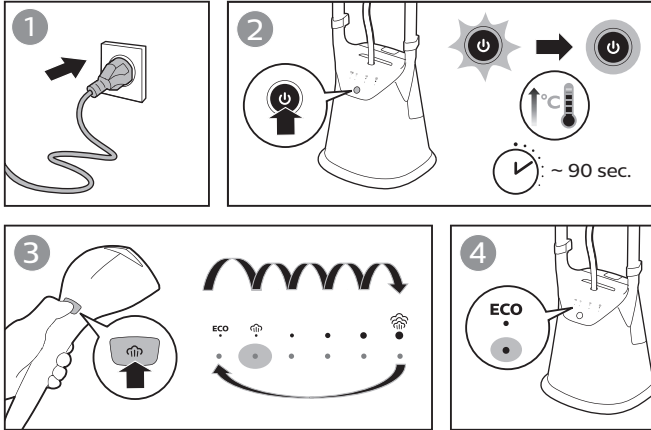

EN The power button flashes indicating that the appliance is heating up. When the appliance is ready for use after 90 seconds, the light turns steady.

By using the ECO mode (reduced amount of steam), you can save energy without compromising on the ironing result.

KO 전원 버튼의 불이 깜박이면 제품이 가열되고 있다는 의미입니다. 90초 후에 제품을 사용할 준비가 되면 불이 켜진 상태로 유지됩니다.

ECO모드(스팀 발생량 감소)를 사용하면 다리질 효과에는 영향을 미치지 않으면서 에너지를 절약할 수 있습니다.

- MS** Butang kuasa yang berkelip menandakan bahawa perkakas sedang dipanaskan. Apabila perkakas sedia untuk digunakan selepas 90 saat, lampu akan berhenti berkelip.
Dengan mod ECO (pengurangan jumlah stim), anda boleh menjimatkan tenaga tanpa mengurangkan hasil penyeterikaan.
- TH** ปุ่มเปิด/ปิดจะกระพริบเพื่อบ่งบอกว่าตอนนี้เครื่องกำลังร้อน เมื่อเครื่องพร้อมทำการใช้งานหลังจาก 90 วินาที ไฟจะติดค้าง
การใช้โหมด ECO (ลดปริมาณไอน้ำ) จะช่วยให้คุณประหยัดพลังงานโดยไม่ทำให้ผลลัพธ์การรีดผ้าด้อยลง
- VI** Đèn báo nút nguồn nhấp nháy cho biết thiết bị đang được làm nóng. Sau 90 giây, thiết bị đã sẵn sàng để sử dụng và đèn báo sẽ sáng liên tục.
Với chế độ tiết kiệm (giảm lượng hơi nước), bạn có thể tiết kiệm năng lượng mà không làm ảnh hưởng đến kết quả ủi.
- SC** 电源开关闪烁表示产品正在加热。当产品在 90 秒后准备就绪时，指示灯将持续亮起。
使用 ECO 环保节能模式（减少蒸汽量），可以节省能源而不影响熨烫效果。
- TC** 電源按鈕閃爍表示產品正在加熱。待 90 秒後產品可供使用時，指示燈會持續亮起。
使用 ECO 模式（蒸氣量會減少）可以節省能源，但仍然可獲得相近的熨燙效果。

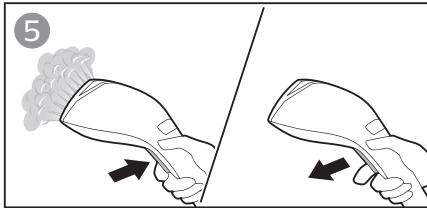

- EN** Press and hold the steam trigger to start steaming.
Release the steam trigger for steam stop.
- KO** 스팀을 시작하려면 스팀 버튼을 누른 채로 기다립니다.
스팀 버튼을 놓아 스팀 분사를 멈춥니다.
- MS** Tekan dan tahan picu stim untuk memulakan penstim.
Lepaskan picu stim untuk menghentikan stim.
- TH** กดปุ่มไ้พลังไอน้ำค้างไว้เพื่อเริ่มการรีดผ้า
ปล่อยปุ่มไ้พลังไอน้ำเพื่อหยุดปล่อยไอน้ำ
- VI** Nhấn và giữ nút bấm hơi nước để bắt đầu ủi.
Nhả nút bấm hơi nước để dừng tạo hơi nước.
- SC** 按住蒸汽开关，开始熨烫。
松开蒸汽开关可停止释放蒸汽。
- TC** 按住蒸氣觸動器以開始熨燙。
放開蒸氣觸動器以停止釋出蒸氣。

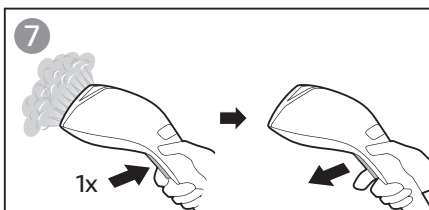
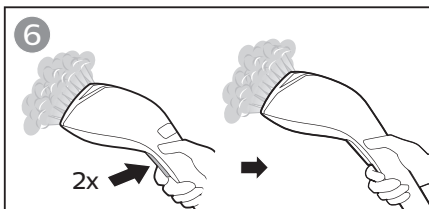

EN Steam lock

Double tap the steam trigger for continuous steam .

Press the steam trigger once to deactivate steam lock.

The steam lock comes with automatic release function, which can prevent continuous steaming when the appliance is left unattended.

After 10 minutes activation of steam lock, steam will stop automatically. This is normal.

Double tap on the steam trigger again and steam will be emitted continuously.

KO 스팀 연속 버튼

스팀 버튼을 두 번 누르면 연속 스팀이 분사됩니다.

스팀 버튼을 한 번 누르면 스팀 연속 버튼이 비활성화됩니다.

자동 해제 기능이 있는 스팀 연속 버튼은 일정 기간 동안 사용하지 않으면 제품의 연속 스팀 기능이 중지됩니다.

스팀 연속 버튼을 활성화하고 10분이 지나면 스팀이 자동으로 중지됩니다. 이는 정상적인 현상입니다.

스팀 버튼을 다시 두 번 누르면 연속 스팀이 다시 분사됩니다.

MS Kunci stim

Ketik picu stim dua kali untuk mendapatkan stim berterusan.

Tekan picu stim sekali untuk menyahaktifkan kunci stim.

Kunci stim disertakan fungsi pelepas automatik yang boleh mengelakkan penstiman berterusan apabila perkakas tidak digunakan.

Selepas kunci stim diaktifkan untuk 10 minit, stim akan berhenti secara automatik. Ini perkara biasa.

Ketik picu stim dua kali lagi dan stim akan dikeluarkan secara berterusan.

TH ล็อคพลังไอน้ำ

กดปุ่มใช้พลังไอน้ำสองครั้งเพื่อปล่อยไอน้ำด้วยอัตราต่อเนื่องสูง

กดปุ่มใช้พลังไอน้ำหนึ่งครั้งเพื่อปิดการทำงานปุ่มล็อคพลังไอน้ำ

การล็อคพลังไอน้ำมาพร้อมกับฟังก์ชันการหยุดใช้งานอัตโนมัติ เพื่อช่วยป้องกันการ

การใช้พลังไอน้ำต่อเนื่องเมื่อเครื่องถูกปล่อยไว้โดยไม่มีการดูแล

ไอน้ำจะหยุดโดยอัตโนมัติหลังจากเปิดใช้งานการล็อคพลังไอน้ำเป็นเวลา

10 นาที เป็นเหตุการณ์ปกติ

กดปุ่มใช้พลังไอน้ำสองครั้งอีกครั้งหนึ่ง และไอน้ำจะกระจายตัวอย่างต่อเนื่อง

VI Khóa hơi nước

Chạm 2 lần vào nút bấm hơi nước để duy trì hơi nước.

Nhấn 1 lần vào nút bấm hơi nước để tắt khóa hơi nước.

Khóa hơi nước được trang bị chức năng nhả tự động, giúp ngăn ngừa việc tạo hơi nước liên tục trong khi thiết bị không được giám sát.

Trong vòng 10 phút kể từ khi khóa hơi nước được kích hoạt, hơi nước sẽ tự động ngừng. Đây là hiện tượng bình thường.

Chạm lại 2 lần vào nút bấm hơi nước và hơi nước sẽ phun trở lại.

SC 蒸汽锁

双击蒸汽开关以获得持久蒸汽。

按下蒸汽开关一次以停用蒸汽锁。

此蒸汽锁配有自动释放功能，可防止产品在无人看管时连续释放蒸汽。

蒸汽锁启动 10 分钟后，蒸汽将自动停止。这是正常的。

再次双击蒸汽开关，蒸汽将持续喷出。

TC 蒸氣鎖

輕按兩下蒸氣觸動器以啟動連續蒸氣功能。

按一下蒸氣觸動器以關閉蒸氣鎖。

蒸氣鎖附有自動釋放功能，可在產品閒置不用時，避免持續釋出蒸氣。

啟動蒸氣鎖 10 分鐘後，蒸氣會自動停止。此為正常現象。

再次輕按兩下蒸氣觸動器，就會持續釋出蒸氣。

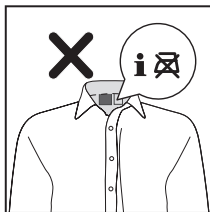
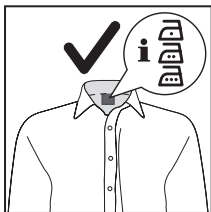

EN This appliance comes with OptimalTEMP technology steam plate.

It enables you to steam all types of ironable fabrics, in any order and without sorting your garments.

Warning: Do not steam on non-ironable fabrics.

KO 본 제품에는 자동 온도 설정 기술이 적용된 스팀 열판이 포함되어 있습니다.

이를 통해 의류를 분류하지 않고 다림질이 가능한 모든 종류의 옷감에 스팀을 사용할 수 있습니다.

주의: 다림질이 불가능한 옷감에는 스팀을 사용하지 마십시오.

- MS** Perkakas ini dilengkapi dengan plat stim teknologi OptimalTEMP. Teknologi ini membolehkan anda menyeterika semua jenis fabrik yang boleh diseterika, dalam apa-apa jua tertib tanpa mengisih pakaian anda.
Amaran: Jangan stim fabrik yang tidak boleh diseterika.
- TH** เครื่องนี้มาพร้อมกับแผ่นไอน้ำเทคโนโลยี OptimalTEMP ซึ่งจะทำให้คุณสามารถรีดผ้าทุกชนิดของเนื้อผ้าที่สามารถรีดได้ทั้งหมด โดยจัดลำดับการรีดอย่างไรก็ได้โดยไม่ต้องคัดแยกชนิดของผ้า
คำเตือน: อย่ารีดไอน้ำกับผ้าที่รีดไม่ได้
- VI** Thiết bị này được trang bị mặt đế ủi hơi nước sử dụng công nghệ nhiệt độ tối ưu OptimalTEMP.
Mặt đế ủi hơi nước cho phép bạn ủi tất cả các loại vải ủi được, theo bất kỳ thứ tự nào mà không cần phải phân loại trước quần áo.
Cảnh báo: Không được ủi trên các loại vải không ủi được.
- SC** 本产品配有 OptimalTEMP 智能温控科技蒸汽面板。可让您使用蒸汽熨各种类型的可熨烫面料，可采用任何顺序而无需分类您的衣物。
警告: 切勿用蒸汽熨不可熨烫的面料。
- TC** 本產品隨附 OptimalTEMP 技術蒸氣噴頭。讓您無需為衣物分類，便能以各種順序使用蒸氣熨燙各種可熨燙衣料。
警告: 請勿以蒸氣熨燙不可熨燙的衣料。

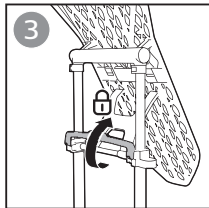
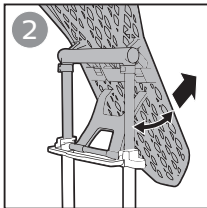
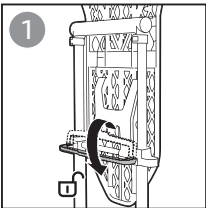
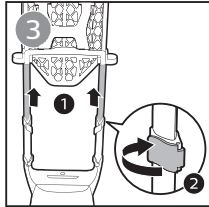
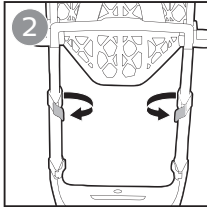
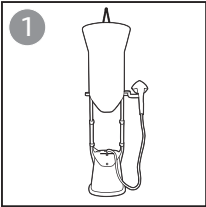

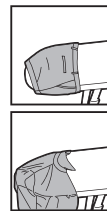
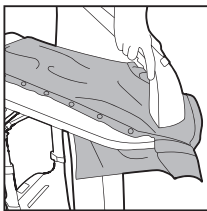
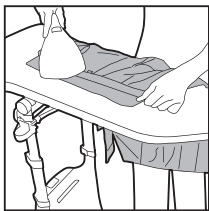
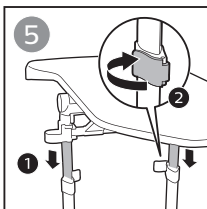
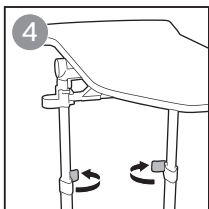
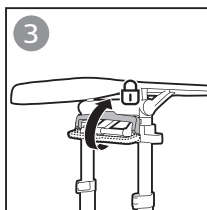
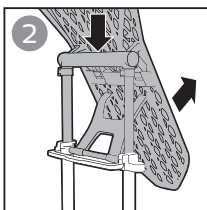
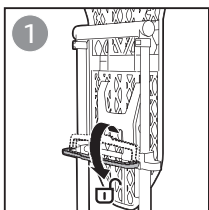
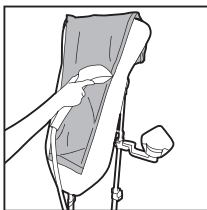
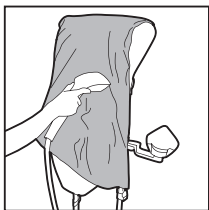

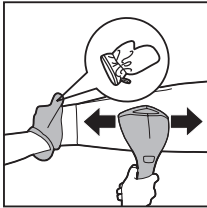

- EN** Put the glove on the hand you are using to hold a garment. The glove protects your hand against the steam from the steamer head.
- KO** 옷감을 잡는 손에는 장갑을 끼십시오. 장갑이 스티머 헤드에서 나오는 스팀으로부터 손을 보호해 줍니다.
- MS** Pakai sarung tangan pada tangan yang anda gunakan untuk memegang pakaian. Sarung tangan melindungi tangan anda daripada stim yang keluar daripada kepala penstim.
- TH** สวมถุงมือข้างที่คุณใช้จับผ้า ถุงมือจะปกป้องมือของคุณจากไอน้ำที่พ่นออกมาจากหัวพ่นไอน้ำ
- VI** Đeo găng tay vào tay bạn định dùng để giữ quần áo. Găng tay giúp tránh bị bỏng da tay do hơi phun từ đầu bàn ủi.
- SC** 将防烫手套戴在拿着衣物的手上。防烫手套可保护您的手不被蒸汽喷头所喷出的蒸汽烫伤。
- TC** 將手套穿戴在要固定衣物的那一隻手。手套可以保護您的手不被蒸氣噴頭的蒸氣燙傷。

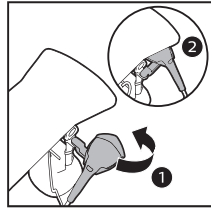
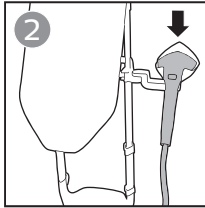
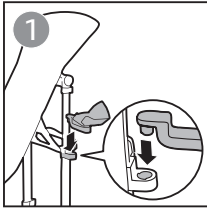

EN This side docking allows you to access steamer head conveniently without the hassle of reaching high up. You can choose to use the side docking at either the right side or left side of the device.

We recommend you to switch off your continuous steam when you are using the side docking.

Caution: Keep the steamer head away from children to avoid burning.

KO 높이 들어올릴 필요 없이 측면 도크를 통해 스티머 헤드에 편하게 액세스할 수 있습니다. 장치의 우측 또는 좌측 있는 측면 도크를 사용하도록 선택할 수 있습니다.

측면 도크를 사용할 경우 연속 스티머는 꺼두는 것이 좋습니다.

주의: 화상을 방지하기 위해 어린이가 스티머 헤드에 접근하지 못하도록 하십시오.

MS Dok sisi ini membolehkan anda mencapai kepala penstim dengan mudah tanpa kesukaran. Anda boleh menggunakan dok sisi pada sebelah kanan atau sebelah kiri peranti.

Kami mengesyorkan anda mematikan stim berterusan apabila anda menggunakan dok sisi.

Awas: Jauhkan kepala penstim daripada kanak-kanak untuk mengelakkan kecederaan.

- TH** แทนด้านข้างจะช่วยให้คุณใช้งานหัวฟ่นไอน้ำได้อย่างสะดวกโดยไม่ต้องเอื้อมมือไปหยิบสูงๆ ให้อยู่ยาก คุณสามารถเลือกใช้งานแทนด้านข้างที่ด้านขวาหรือด้านซ้ายก็ได้
- เราแนะนำให้ท่านปิดปลั๊กไอน้ำต่อเนื่องเมื่อคุณใช้งานแทนด้านข้าง
- ข้อควรระวัง:** เก็บหัวฟ่นไอน้ำให้ห่างจากเด็กเพื่อหลีกเลี่ยงการถูกความร้อนจากเตารีด
- VI** Đỡ dụng bên giúp bạn dễ dàng với tới đầu bàn ủi hơi nước mà không phải nhón cao. Bạn có thể chọn sử dụng đỡ dụng bên ở bên phải hoặc bên trái thiết bị.
- Chúng tôi khuyên bạn nên tắt chế độ hơi nước liên tục khi sử dụng đỡ dụng bên.
- Chú ý:** Không để trẻ nhỏ đến gần đầu bàn ủi hơi nước để tránh bị bỏng.
- SC** 这种侧面喷头支架使您可以方便地拿起蒸汽喷头，让您无需抬手太高。
- 我们建议您在使用侧面喷头支架时关闭持久蒸汽功能。
- 注意：**请保持蒸汽喷头远离儿童，以免烫伤。
- TC** 側基座可讓您方便使用蒸氣噴頭，無需費力至高處拿取。您可以選擇在裝置的右側或左側使用側基座。
- 我們建議您在使用側基座時，關閉連續蒸氣功能。
- 注意：**請勿讓孩童靠近蒸氣噴頭以免燙傷。

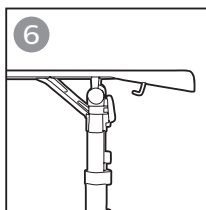
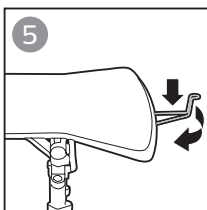
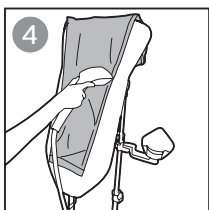
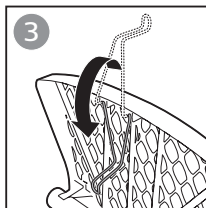
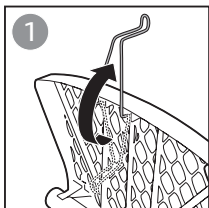

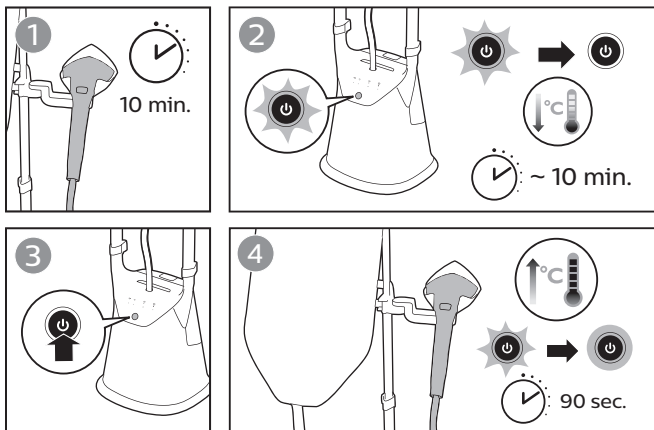

EN The appliance comes with an auto shut-off feature.
When the steamer head is placed onto the holder and the appliance has not been used for more than 10 minutes, the power button flashes and the appliance starts to cool down.
Upon leaving the appliance untouched for the next 10 minutes, it will switch off automatically.

Press the power button to let the appliance reheat.

KO 제품에는 자동 전원 차단 기능이 포함되어 있습니다.
스티머 헤드가 홀더에 놓인 상태로 제품을 10분 이상 사용하지 않을 경우 전원 버튼의 불이 깜박이고 제품이 식기 시작합니다.
10분 간 제품을 놔둘 경우 자동으로 전원 버튼이 꺼집니다.
제품을 다시 가열하려면 전원 버튼을 누르십시오.

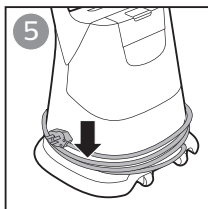
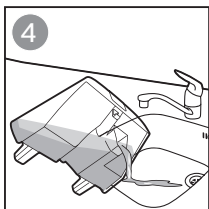
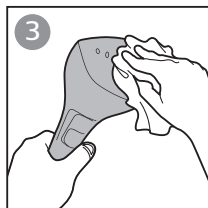
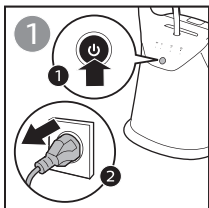

- MS** Perkakas disertakan ciri pematian automatik.
Apabila kepala penstim diletakkan pada pemegang dan perkakas tidak digunakan untuk lebih daripada 10 minit, butang kuasa akan berkelip dan perkakas akan mula menyekuj.
Jika perkakas tidak digunakan untuk 10 minit yang seterusnya, perkakas akan dimatikan secara automatik.
Tekan butang kuasa untuk memanaskan semula perkakas.
- TH** เครื่องมาพร้อมกับระบบตัดไฟอัตโนมัติ
เมื่อวางหัวพ่นไอน้ำไว้บนที่ยึดและไม่ได้ใช้งานเครื่องเป็นเวลามากกว่า 10 นาที ปุ่มเปิด/ปิดจะกระพริบและเครื่องก็จะเย็นลง
เมื่อเราปล่อยเครื่องทิ้งไว้โดยไม่ได้ทำอะไรเลยต่อไปอีก 10 นาที เครื่องจะปิดตัวเองโดยอัตโนมัติ
กดปุ่มเปิด/ปิดเพื่อให้เครื่องทำความร้อนอีกครั้ง
- VI** Thiết bị được trang bị tính năng ngắt điện tự động.
Khi đầu bàn ủi hơi nước được đặt trên kẹp giữ và thiết bị không được sử dụng sau hơn 10 phút, nút nguồn sẽ nhấp nháy và thiết bị sẽ bắt đầu nguội dần.
Nêu tiếp tục không được sử dụng trong vòng 10 phút tiếp theo, thiết bị sẽ tự động ngắt điện.
Nhấn nút nguồn để thiết bị làm nóng lại.
- SC** 本产品带有自动关熄功能。
当蒸汽喷头放置在支架上且产品超过 10 分钟未使用时，电源开关将闪烁，产品将开始冷却。
如果在接下来的 10 分钟内没有触碰产品，产品将自动关闭。
按下电源开关让产品重新加热。
- TC** 本產品具備自動斷電功能。
若蒸氣噴頭放在固定座上，但產品超過 10 分鐘未使用，電源按鈕便會閃爍，產品也會開始冷卻。
若接下來的 10 分鐘未使用產品，產品將自動關閉。
請按下電源按鈕，讓產品重新加熱。

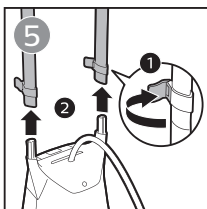
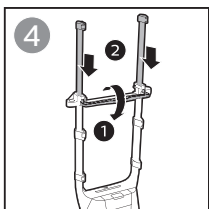
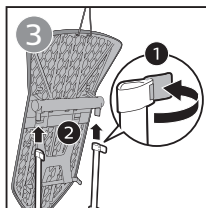
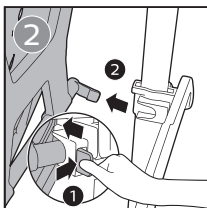
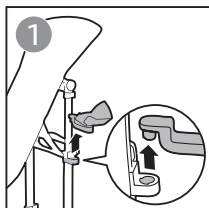
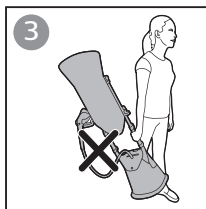
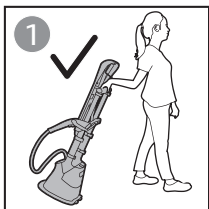











EN

Problem	Possible cause	Solution
The appliance produces no steam.	The steamer has not heated up sufficiently (power button flashes).	Let the appliance heat up for 90 seconds. When the appliance is ready for use, the light turns steady.
	Auto shut-off has been activated when the appliance has not been used for more than 10 minutes (power button flashes).	Press the power button and wait for 90 seconds for the appliance to heat up again.
	Steam trigger has not been pressed to emit steam.	Press the steam trigger to activate steam.
	Low water level in the tank or the tank is not inserted properly.	Refill the water tank and insert it properly.
	Steam lock has been activated for 10 minutes.	Steam lock feature comes with automatic release function. Double tap on the steam trigger again for continuous steam (refer to ).
Water leaks out from the steamer base.	The water tank is not inserted properly.	Insert the tank properly.
	Water tank has been overfilled.	Fill water up to its MAX marking.
Steam lock cannot be activated.	Fail to enter steam lock function.	Double tap to activate the steam lock function (refer to ).

Problem	Possible cause	Solution
Steam does not stop automatically after placing the steamer head onto the holder.	Steam lock function is activated.	Press once to deactivate steam lock (refer to ).
The board cover becomes wet or there are water droplets on the garment during steaming.	Steam has condensed on the board cover after a long steaming session.	Leave it to dry before storage. Replace the board cover if it has worn out. Purchase a new board cover from a Philips Authorized Service Center.
Board is shaky during use.	The poles are not installed properly or the board is not secured onto the poles.	Refer to  for correct installation.
	The board lock is not fully inserted.	Insert the two board locks fully until you hear a “click” sound (refer to ).
	The board is not fully secure in vertical position.	Make sure that the board tilting lever is in a locked position before attaching it to the poles (refer to ).
Board cannot be tilted or be used in horizontal position.	The board lock is not locked onto the pole.	Ensure that the board lock is in a locked position (refer to ).

Problem	Possible cause	Solution
	The board tilting lever has not been released.	<p>Ensure unlocking tilting lever to allow board to be tilted to its desired position.</p> <p>Once a desired position is attained, lock the tilting lever to secure board. (refer to  / )</p>
Water droplets drip from the steamer head, sometimes the appliance produces a croaking sound.	Steam condenses into water in the hose and affect smooth steam flow.	Lift the steamer head to straighten the hose vertically. At the start of a steaming session, set the steam setting to be in MAX mode. Hold the steamer head away from the garment and press the steam trigger for 10 seconds to release the initial gush of water droplets.
Dirty water, brown stains or white flakes come out of the steamer head and stain the garment.	Chemical or additives is added into the water tank.	<p>Never use chemical or additives with the appliance. Fill the water tank with water and allow it to steam out 1 full tank to rinse off chemical residues.</p> <p>For stain on garment, rinse off any stains under running water.</p> <p>For stain on steamer head, wipe any deposits off the steamer head with a damp cloth.</p>



Problem	Possible cause	Solution
	<p>Depending on where you stay, the water hardness level may be high and results in fast scale builds up.</p>	<p>Ensure that water tank is emptied after a steaming session. It is recommended to use a combination of demineralization/distilled water (50%) mixed with tap water (50%). At the start of a steaming session, set the steam setting to be in MAX mode. Hold the steamer head away from the garment and press the steam trigger for 10 seconds to release the initial gush of water droplets.</p> <p>For stain on garment, rinse off any stains under running water.</p> <p>For stain on steamer head, wipe any deposits off the steamer head with a damp cloth.</p>



KO

문제점	예상 원인	해결책
제품에서 스팀이 나오지 않습니다.	스팀머가 충분히 가열되지 않았습니다. (전원 버튼 깜박임).	제품이 예열될 때까지 90초간 기다리십시오. 제품을 사용할 준비가 되면 불이 계속 켜진 상태로 유지됩니다.
	제품이 10분 이상 사용되지 않아 자동 전원 차단 기능이 활성화되었습니다. (전원 버튼 깜박임).	전원 버튼을 누르고 제품이 다시 예열될 때까지 90초간 기다리십시오.
	스팀 버튼을 누르지 않아 스팀이 분사되지 않았습니다.	스팀 버튼을 눌러 스팀을 활성화합니다.
	탱크에 물이 부족하거나 탱크가 제대로 꽂혀 있지 않습니다.	물 탱크를 다시 채우고 제대로 꽂으십시오.
	스팀 연속 버튼이 10분간 활성화되었습니다.	스팀 연속 버튼에는 자동 해제 기능이 포함되어 있습니다. 연속 스팀을 분사하려면 스팀 버튼을 다시 두 번 누릅니다 (참조).
스팀머 받침대에서 물이 셉니다.	물탱크를 올바르게 끼우지 않았습니다.	탱크를 제대로 끼우십시오.
	물탱크에 물을 너무 많이 채웠습니다.	물을 MAX로 표시된 부분까지만 채우십시오.
스팀 연속을 활성화할 수 없습니다.	스팀 연속 기능을 실행할 수 없습니다.	두 번 눌러 스팀 연속 기능을 활성화합니다 (참조).



문제점	예상 원인	해결책
스팀머 헤드를 홀더에 놓았는데도 스팀 분사가 자동으로 멈추지 않습니다.	스팀 연속 기능이 활성화되었습니다.	한번 눌러 스팀 연속 기능을 비활성화합니다 (☞ 참조).
스팀 분사 도중 다림판 덮개가 젖거나 옷감에 물방울이 떨어집니다.	장시간 스팀 다림질을 할 경우 다림판 덮개 위에 스팀이 응축됩니다.	다림판이 마른 다음 보관하십시오. 소재가 낡은 경우 다림판 덮개를 교체하십시오. 필립스 공인 서비스 센터에서 새 다림판 덮개를 구입하십시오.
다림판을 사용할 때 흔들립니다.	봉이 제대로 끼워지지 않았거나 다림판이 봉에 올바르게 장착되지 않았습니다.	☞을 참조하여 올바른 설치법을 확인하십시오.
	다림판 잠금 장치가 제대로 끼워지지 않았습니다.	“딸깍” 소리가 날 때까지 두 다림판 잠금 장치를 완전히 끼우십시오 (☞ 참조).
	다림판이 수직 위치에 놓여있지 않습니다.	봉 위에 부착하기 전에 다림판 기울기 레버가 잠김 상태인지 확인하십시오(☞ 참조).
다림판은 기울일 수 없으며 수평 방향에서 사용할 수 없습니다.	다림판 잠금 장치가 봉에 고정되어 있지 않습니다.	다림판 잠금 장치가 잠금 위치에 있는지 확인하십시오(☞ 참조).



문제점	예상 원인	해결책
	다림판 기울기 레버가 풀리지 않았습니다.	<p>다림판을 원하는 위치로 기울려면 기울기 레버 잠금을 해제해야 합니다.</p> <p>원하는 위치에서 기울기 레버를 잠가 다림판을 고정합니다.</p> <p> /  참조)</p>
스티머 헤드에서 물방울이 떨어지고, 다리미에서 끓는 소리가 날 때가 있습니다.	스팀이 호스에서 물로 응결되어 원활할 스팀 흐름에 영향을 미칩니다.	스티머 헤드를 올려 호스를 곧게 펴니다. 스팀 다리미질을 시작할 때, 스팀 설정을 MAX 모드로 설정합니다. 스티머 헤드를 옷감에서 떨어진 위치에서 잡고, 스팀 버튼을 10초간 눌러 처음 물방울을 분사합니다.
스티머 헤드에서 더러운 물, 갈색 얼룩 또는 흰 가루가 나와서 옷감에 얼룩이 생깁니다.	화학물질이나 첨가물이 물탱크에 추가되었습니다.	<p>제품에는 화학물질이나 첨가물을 절대 사용하지 마십시오. 물탱크에 물을 채우고, 물탱크가 빌 때까지 스팀을 분사하여 화학 잔여물을 행귀냅니다.</p> <p>옷감에 얼룩이 생긴 경우 흐르는 물로 행귀냅니다.</p> <p>스티머 헤드에 얼룩이 있는 경우 젖은 천으로 스티머 헤드에 묻은 불순물을 닦아냅니다.</p>



문제점	예상 원인	해결책
	<p>거주 지역에 따라 물 경도 수준이 높아 석회질이 빠르게 쌓일 수 있습니다.</p>	<p>스팀 다림질 후에는 물탱크를 비우십시오. 탈염수/증류수를 수돗물과 반씩 섞어서 사용하는 것이 좋습니다. 스팀 다림질을 시작할 때, 스팀 설정을 MAX 모드로 설정합니다. 스티머 헤드를 옷감에서 떨어진 위치에서 잡고, 스팀 버튼을 10초간 눌러 처음 물방울을 분사합니다.</p> <p>옷감에 얼룩이 생긴 경우 흐르는 물로 헹궈냅니다.</p> <p>스티머 헤드에 얼룩이 있는 경우 젖은 천으로 스티머 헤드에 묻은 불순물을 닦아냅니다.</p>



MS

Masalah	Penyebab yang mungkin	Penyelesaian
Perkakas tidak mengeluarkan stim.	Penstim tidak memanans dengan secukupnya (butang kuasa berkelip).	Biarkan perkakas memanans selama 90 saat. Apabila perkakas sedia untuk digunakan, lampu akan berhenti berkelip.
	Fungsi pematian automatik diaktifkan apabila perkakas tidak digunakan selama lebih 10 minit (butang kuasa berkelip).	Tekan butang kuasa dan tunggu 90 saat agar perkakas dipanaskan semula.
	Picu stim tidak ditekan untuk mengeluarkan stim.	Tekan picu stim untuk mengaktifkan stim.
	Air di dalam tangki tidak mencukupi atau tangki tidak dimasukkan dengan betul.	Isi semula tangki air dan masukkan dengan betul.
	Kunci stim telah diaktifkan untuk 10 minit.	Ciri kunci stim disertakan fungsi pelepas automatik. Tekan picu stim dua kali lagi untuk mendapatkan stim berterusan (rujuk ).
Air keluar daripada tapak penstim.	Tangki air tidak dimasukkan dengan betul.	Masukkan tangki dengan betul.
	Tangki air diisi berlebihan.	Isi air sehingga tanda MAX .
Kunci stim tidak dapat diaktifkan.	Gagal mengaktifkan fungsi kunci stim.	Ketik dua kali untuk mengaktifkan fungsi kunci stim (rujuk ).



Masalah	Penyebab yang mungkin	Penyelesaian
Stim tidak berhenti secara automatik selepas kepala penstim diletakkan pada pemegang.	Fungsi kunci stim diaktifkan.	Tekan sekali untuk menyahaktifkan kunci stim (rujuk ).
Alas papan menjadi basah atau terdapat titisan air pada pakaian semasa menstim.	Stim telah memeluwap pada alas papan selepas sesi penstimanan yang lama.	Biarkan alas papan mengering sebelum menyimpan. Gantikan alas papan jika telah haus. Beli alas papan yang baru dari Pusat Servis Philips yang Sah.
Papan bergoyang sewaktu digunakan.	Dirian tidak dipasangkan dengan betul atau papan tidak dipasangkan ketat pada dirian.	Rujuk  untuk melihat cara pemasangan yang betul.
	Kunci papan tidak dimasukkan sepenuhnya.	Masukkan dua kunci papan dengan sepenuhnya sehingga anda mendengar bunyi “klik” (rujuk ).
	Papan tidak kukuh dalam kedudukan menegak.	Pastikan tuil pencondong papan dikunci sebelum dipasangkan pada dirian (rujuk ).
Papan tidak boleh dicondongkan atau digunakan dalam kedudukan mendatar.	Kunci papan tidak dikunci pada dirian.	Pastikan kunci papan dalam kedudukan terkunci (rujuk ).





Masalah	Penyebab yang mungkin	Penyelesaian
	<p>Tuil pencondong papan tidak dilepaskan.</p>	<p>Pastikan anda membuka kunci tuil pencondong untuk membolehkan papan dicondongkan pada kedudukan yang dikehendaki.</p> <p>Selepas kedudukan yang dikehendaki tercapai, kuncikan tuil pencondong untuk menstabilkan papan.. (rujuk  / )</p>
<p>Titisan air menitis daripada kepala penstim, kadangkala perkakas mengeluarkan bunyi menguak.</p>	<p>Stim memeluap menjadi air di dalam hos dan menjejaskan kelancaran aliran stim.</p>	<p>Angkat kepala penstim untuk meluruskan hos secara menegak. Pada permulaan sesi penstim, tetapkan tetapan stim kepada mod MAX. Pegang kepala penstim jauh dari pakaian dan tekan picu stim selama 10 saat untuk melepaskan aliran pertama titisan air.</p>
<p>Air kotor, kotoran perang atau emping putih keluar dari kepala penstim dan mengotori pakaian.</p>	<p>Kimia atau tambahan ditambahkan ke dalam tangki air.</p>	<p>Jangan gunakan bahan kimia atau tambahan dengan perkakas. Isikan air ke dalam tangki air dan biarkan stim keluar sehingga tangki kosong untuk membersihkan sisa kimia.</p> <p>Untuk kotoran pada pakaian, cuci kotoran di bawah paip air.</p> <p>Untuk kotoran pada kepala penstim, lap mendapan pada kepala penstim menggunakan kain lembap.</p>



Masalah	Penyebab yang mungkin	Penyelesaian
	<p>Bergantung pada lokasi kediaman anda, paras keliatan air mungkin tinggi dan menyebabkan pengumpulan kerak yang pantas.</p>	<p>Pastikan tangki air dikosongkan selepas sesi penstim. Anda dicadangkan agar menggunakan campuran air tanpa mineral/suling (50%) dicampurkan dengan air paip (50%).</p> <p>Pada permulaan sesi penstim, tetapkan tetapan stim kepada mod MAX. Pegang kepala penstim jauh dari pakaian dan tekan picu stim selama 10 saat untuk melepaskan aliran pertama titisan air.</p> <p>Untuk kotoran pada pakaian, cuci kotoran di bawah paip air.</p> <p>Untuk kotoran pada kepala penstim, lap mendapan pada kepala penstim menggunakan kain lembap.</p>



TH

ปัญหา	สาเหตุที่เป็นไปได้	การแก้ปัญหา
เครื่องไม่พ่นไอน้ำ	เครื่องพ่นไอน้ำทำความร้อนไม่เพียงพอ (ปุ่มเปิด/ปิดกระพริบ)	ปล่อยให้เครื่องทำความร้อน 90 วินาที เมื่อเครื่องพร้อมทำการใช้งาน ใหม้จะติดค้าง
	การตัดไฟอัตโนมัติจะทำงานเมื่อไม่ได้ใช้เครื่องนานเกินกว่า 10 นาที (ปุ่มเปิด/ปิดกระพริบ)	กดปุ่มเปิด/ปิดและรอเป็นเวลา 90 วินาทีเพื่อให้เครื่องทำความร้อนอีกครั้ง
	ไม่ได้ทำการกดปุ่มใช้พลังไอน้ำเพื่อทำการกระจายไอน้ำ	กดปุ่มใช้พลังไอน้ำเพื่อเปิดใช้งานไอน้ำ
	ระดับน้ำในแท็งก์ต่ำหรือใส่แท็งก์น้ำไม่ถูกต้อง	เติมน้ำในแท็งก์น้ำแล้วใส่แท็งค์ให้ถูกต้อง
	เปิดการลือกพลังไอน้ำ 10 นาที	คุณสมบัตการลือกพลังไอน้ำมาพร้อมกับฟังก์ชันการหยุดใช้งานอัตโนมัติ กดปุ่มใช้พลังไอน้ำสองครั้งเพื่อปล่อยไอน้ำด้วยอัตราต่อเนื่องสูง (ดูส่วน )
น้ำรั่วออกมาจากฐานเครื่องพ่นไอน้ำ	ใส่แท็งค์น้ำไม่ถูกต้อง	ประกอบแท็งค์ให้เข้าที่
	ใส่น้ำในแท็งค์น้ำมากเกินไป	เติมน้ำในแท็งค์ให้ถึงแค่ขีดแสดงระดับสูงสุด (MAX)
การลือกพลังไอน้ำไม่สามารถใช้งานได้	ล้มเหลวในการใช้งานฟังก์ชันลือกพลังไอน้ำ	กดปุ่มสองครั้งเพื่อเปิดการใช้งานฟังก์ชันลือกพลังไอน้ำ (ดูส่วน )

ปัญหา	สาเหตุที่เป็นไปได้	การแก้ปัญหา
ไอน้ำไม่หยุดการ ใช้งานอัตโนมัติหลังจากวางหัวฟนไอน้ำ บนที่ยึด	เปิดใช้งานฟังก์ชันล๊อค พลังไอน้ำ	กดปุ่มหนึ่งครั้งเพื่อปิดการใ้ งานการล๊อคพลังไอน้ำ (ดูส่วน )
ผ้ารองรีดเปียกหรือ มีหยดน้ำหยดลงบน ผ้าระหว่างรีดไอน้ำ	ไอน้ำกลั่นตัวบนผ้ารองรีด หลังจากรีดไอน้ำเป็นเวลา ยาวนาน	ปล่อยให้เครื่องแห้งก่อนทำการ จัดเก็บ เปลี่ยนผ้ารองรีดเมื่อเริ่ม สึกหรือ ซื้อผ้ารองรีดใหม่ได้จาก ศูนย์บริการที่ได้รับอนุญาตจาก Philips
โต๊ะรองรีดโอนออน ระหว่างใช้	เสาค้ำไม่ได้ทำการติดตั้งอย่าง ถูกต้องหรือโต๊ะรองรีดไม่ได้ ยึดติดกับเสา	ดูส่วน  สำหรับการติดตั้งที่ ถูกต้อง
	ใส่ตัวล๊อคโต๊ะรองรีดไม่แน่น	ใส่ตัวล๊อคโต๊ะรองรีดเข้าไปให้สุด จนกว่าคุณจะได้ยินเสียง "คลิก" (ดูส่วน )
	โต๊ะรองรีดยึดไม่แน่นใน แนวตั้ง	ต้องแน่ใจว่าคันโยกปรับความ เอียงอยู่ในตำแหน่งล๊อคก่อน ทำการติดตั้งกับเสา (ดูส่วน )
ไม่สามารถเอียงหรือ ใช้งานโต๊ะรองรีดใน แนวนอนได้	ตัวล๊อคโต๊ะรองรีดไม่ได้ล๊อค ติดกับเสา	ตรวจสอบให้แน่ใจว่าตัวล๊อคโต๊ะ รองรีดอยู่ในตำแหน่งล๊อค (ดูส่วน )

ปัญหา	สาเหตุที่เป็นไปได้	การแก้ปัญหา
	<p>คันโยกปรับความเอียงของโต๊ะยังไม่ถูกปล่อยออกมา</p>	<p>ตรวจสอบให้แน่ใจว่าได้ปลดล็อกคันโยกปรับความเอียงแล้วเพื่อให้สามารถเอียงโต๊ะรองรับไปยังตำแหน่งที่ต้องการ</p> <p>เมื่อได้ตำแหน่งที่ต้องการแล้ว ให้ล็อกคันโยกการเอียงเพื่อยึดโต๊ะรองรับ (ดูส่วน  / )</p>
<p>น้ำหยดออกจากหัวฟ่นไอน้ำ บางครั้งเครื่องมีเสียงดัง</p>	<p>ไอน้ำกลั่นตัวเป็นน้ำภายในท่อ และทำให้การไหลของไอน้ำนุ่มนวล</p>	<p>ยกหัวฟ่นไอน้ำขึ้นเพื่อให้สายอยู่ในแนวตั้ง</p> <p>ตอนที่เริ่มต้นขั้นตอนการรีดไอน้ำ ตั้งค่าพลังไอน้ำให้อยู่ในโหมด MAX ถือหัวฟ่นไอน้ำให้ห่างจากผ้าและกดปุ่มใช้พลังไอน้ำเป็นเวลา 10 วินาที เพื่อปล่อยให้หยดน้ำฟ่นออกมา</p>
<p>น้ำสกปรก คราบสี น้ำตาล หรือสะเก็ดสีขาวออกจากหัวฟ่นไอน้ำ และทำให้เกิดคราบบนเสื้อผ้า</p>	<p>สารเคมีหรือสารเติมแต่งถูกใส่ลงในถังค์น้ำ</p>	<p>ห้ามใช้สารเคมีหรือสารเติมแต่งกับเครื่อง เติมน้ำลงในถังค์น้ำด้วยน้ำสะอาด และปล่อยให้เครื่องฟ่นไอน้ำออกให้หมด 1 ถังค์เต็มๆ เพื่อล้าง สารเคมีตกค้าง</p> <p>สำหรับคราบบนเสื้อ สามารถล้างออกได้ด้วยน้ำก๊อก</p> <p>สำหรับคราบที่หัวฟ่นไอน้ำ สามารถเช็ดคราบสกปรกออกจากหัวฟ่นไอน้ำด้วยผ้าชุบน้ำหมาด</p>



ปัญหา	สาเหตุที่เป็นไปได้	การแก้ปัญหา
	<p>ระดับความกระด้างของน้ำอาจสูงและส่งผลให้ตะกอนสะสมได้รวดเร็ว ซึ่งขึ้นอยู่กับสถานที่อยู่อาศัยของคุณ</p>	<p>ตรวจดูให้แน่ใจว่าไม่มีน้ำในถังค้แล้วหลังจากการพ่นไอน้ำเสร็จสิ้น ขอแนะนำให้ใช้การผสมผสานระหว่างน้ำปราศจากแร่ธาตุ/น้ำกลั่น (50%) กับน้ำก๊อก (50%)</p> <p>ตอนที่เริ่มต้นขั้นตอนการรีดไอน้ำ ตั้งค่าพลังไอน้ำให้อยู่ในโหมด MAX ถือหัวพ่นไอน้ำให้ห่างจากผ้าและกดปุ่มใช้พลังไอน้ำเป็นเวลา 10 วินาที เพื่อปล่อยให้หยดน้ำพุ่งออกมา</p> <p>สำหรับคราบบนเสื้อ สามารถล้างออกได้ด้วยน้ำก๊อก</p> <p>สำหรับคราบที่หัวพ่นไอน้ำ สามารถเช็ดคราบสกปรกออกจากหัวพ่นไอน้ำด้วยผ้าชุบน้ำหมาด</p>



VI

Sự cố	Nguyên nhân có thể	Giải pháp
Thiết bị không tạo ra hơi nước.	Bàn ủi hơi nước vẫn chưa đủ nóng (nút nguồn nhấp nháy).	Để thiết bị nóng lên trong 90 giây. Khi thiết bị đã sẵn sàng để sử dụng, đèn sẽ sáng liên tục.
	Chức năng tự động ngắt điện được kích hoạt khi thiết bị không được sử dụng trong hơn 10 phút (nút nguồn nhấp nháy).	Nhấn nút nguồn và chờ trong 90 giây để thiết bị làm nóng lại.
	Chưa nhấn nút bấm hơi nước để tạo hơi nước.	Nhấn nút bấm hơi nước để tạo hơi nước.
	Ngăn chứa sắp hết nước hoặc ngăn chứa nước không được lắp đúng cách.	Châm lại nước vào ngăn chứa nước và lắp ngăn chứa đúng cách.
	Khóa hơi nước đã được kích hoạt trong 10 phút.	Tính năng khóa hơi nước đi kèm với chức năng tự động nhả. Chạm lại 2 lần vào nút bấm hơi nước để tạo hơi nước liên tục (tham khảo ).
Nước rỉ ra từ phía bên dưới đế.	Ngăn chứa nước không được lắp đúng cách.	Lắp ngăn chứa nước đúng cách.
	Ngăn chứa nước quá đầy.	Đổ nước tới vạch MAX (TỐI ĐA) của ngăn chứa nước.
Không thể kích hoạt khóa hơi nước.	Chưa chuyển sang chức năng khóa hơi nước.	Chạm 2 lần để kích hoạt chức năng khóa hơi nước (tham khảo ).

Sự cố	Nguyên nhân có thể	Giải pháp
Hơi nước không tự động ngừng sau khi đặt đầu bàn ủi hơi nước lên giá kẹp.	Chức năng Khóa hơi nước được kích hoạt.	Nhấn 1 lần để kích hoạt khóa hơi nước (tham khảo ).
Vỏ bọc ván ủi bị ướt hoặc có nước đọng thành giọt trên quần áo trong khi ủi.	Hơi nước ngưng tụ trên vỏ bọc ván ủi sau khi ủi lâu.	Để vỏ bọc khô trước khi cất đi. Thay vỏ bọc nếu có dấu hiệu bạc màu. Mua vỏ bọc ván ủi mới tại Trung tâm dịch vụ do Philips ủy quyền.
Ván ủi bị rung trong khi sử dụng.	Trụ ván không được lắp đúng cách hoặc ván không được lắp chặt vào trụ.	Tham khảo  để lắp đặt đúng.
	Khóa ván ủi không được lắp chặt.	Lồng hai đầu khóa ván vào nhau cho đến khi bạn nghe thấy tiếng “tách” (tham khảo ).
	Ván ủi không được lắp cố định khi để thẳng đứng.	Đảm bảo rằng chốt lật nghiêng đã được khóa trước khi gắn ván vào trụ (tham khảo ).
Không nghiêng ván ủi được hoặc không đặt ván ủi nằm ngang được.	Khóa ván ủi chưa được khóa chặt vào trụ.	Đảm bảo khóa ván ủi đang ở vị trí khóa (tham khảo ).







Sự cố	Nguyên nhân có thể	Giải pháp
	Bạn chưa nhả chốt lật nghiêng ván ủi.	Đảm bảo mở khóa chốt lật nghiêng để nghiêng ván ủi đến vị trí mong muốn. Khi ván ủi đã ở vị trí mong muốn, hãy khóa chốt lật nghiêng để cố định ván ủi. (tham khảo  / )
Nước nhỏ giọt từ đầu bàn ủi, thỉnh thoảng thiết bị tạo ra tiếng xả khí.	Hơi nước đọng lại thành nước trong ống cấp và ảnh hưởng đến luồng hơi phun.	Nhắc đầu bàn ủi lên để kéo thẳng ống cấp theo chiều dọc. Lúc bắt đầu phiên ủi, hãy chuyển cài đặt hơi phun lên chế độ MAX (Tối đa). Cầm đầu bàn ủi cách xa quần áo và nhân nút bấm hơi nước trong 10 giây để phun thử đợt hơi nước đầu tiên.
Nước bẩn, các vết ô màu hoặc đốm trắng thoát ra từ đầu bàn ủi và làm biến màu bề mặt vải.	Hóa chất hoặc chất phụ gia đã được cho vào ngăn chứa nước.	Không được sử dụng hóa chất hoặc chất phụ gia chung với thiết bị. Châm nước vào ngăn chứa nước và để bàn ủi phun hết ngăn chứa nước để rửa sạch cặn dư hóa chất. Đổi với vết ô trên quần áo, hãy rửa sạch vết ô dưới vòi nước chảy. Đổi với vết ô trên đầu bàn ủi hơi nước, hãy dùng khăn ẩm để lau sạch các chất bám trên đầu bàn ủi.

Sự cố	Nguyên nhân có thể	Giải pháp
	<p>Tùy thuộc vào nơi bạn ở, mức độ cứng của nước có thể cao và dẫn đến việc tích tụ cặn nhanh.</p>	<p>Đảm bảo trút sạch ngăn chứa nước sau khi ủi xong. Khuyến nghị bạn sử dụng hỗn hợp nước cất hoặc nước đã khử khoáng (50%) và nước máy (50%).</p> <p>Lúc bắt đầu phiên ủi, hãy chuyển cài đặt hơi phun lên chế độ MAX (Tối đa). Cầm đầu bàn ủi cách xa quần áo và nhấn nút bấm hơi nước trong 10 giây để phun thử đợt hơi nước đầu tiên.</p> <p>Đôi với vết ô trên quần áo, hãy rửa sạch vết ô dưới vòi nước chảy.</p> <p>Đôi với vết ô trên đầu bàn ủi hơi nước, hãy dùng khăn ẩm để lau sạch các chất bám trên đầu bàn ủi.</p>



SC

问题	可能的原因	解决方法
产品无法产生蒸汽。	蒸汽挂烫机未充分加热（电源开关闪烁）。	让产品加热 90 秒钟。当产品可供使用时，指示灯将持久亮起。
	超过 10 分钟未使用产品时，自动关熄功能启动（电源按钮闪烁）。	按下电源开关并等待 90 秒钟，让产品重新加热。
	未按下蒸汽开关，无法释放蒸汽。	按下蒸汽开关以激活蒸汽功能。
	水箱中的水位低或水箱未正确插入。	为水箱加水并正确装入。
	蒸汽锁已激活 10 分钟。	蒸汽锁闭功能带有自动释放功能。再次双击蒸汽开关以释放持久蒸汽（请参阅  ）。
蒸汽挂烫机底座漏水。	水箱没有正确地插入。	请正确插入水箱。
	水箱加注过量。	将水加至 MAX （最多）标记处。
无法激活蒸汽锁。	未能进入蒸汽锁闭功能。	双击以激活蒸汽锁闭功能（请参阅  ）。
将蒸汽喷头放在支架上后，蒸汽不会自动停止。	蒸汽锁闭功能已激活。	按下一次可停用蒸汽锁（请参阅  ）。





问题	可能的原因	解决方法
熨衣板罩变湿或在熨烫过程中衣物上出现水滴。	长时间熨烫操作后，蒸汽会冷凝在熨衣板罩上。	存放前请将其晾干。如果熨衣板罩已破损，请将其更换。请从飞利浦授权服务中心购买新的熨衣板罩。
熨衣板在使用过程中摇晃。	伸缩杆未装好或熨衣板未固定到伸缩杆上。	请参阅  查看正确安装说明。
	熨衣板锁没有完全插入。	将两个熨衣板锁完全插入，直到听到“咔哒”一声（请参阅  ）。
	熨衣板未完全固定在垂直位置。	请确保可倾斜杆处于锁闭位置，然后再将其安装到伸缩杆上。（请参阅  ）。
熨衣板无法倾斜或在水平位置使用。	熨衣板未锁定在伸缩杆上。	请确保熨衣板锁位于锁定位置(请参阅 )。
	未松开可倾斜杆。	确保将可倾斜杆解锁，以使熨衣板可倾斜到所需位置。 达到所需的位置后，请将倾斜杆锁止以固定熨衣板（请参阅  /  ）
水滴从蒸汽喷头上滴下，有时产品会发出咕噜声。	蒸汽在输送管内凝结成水，影响蒸汽流的平稳畅通。	提起蒸汽喷头以垂直直蒸蒸汽输送管。 在开始蒸汽熨烫时，请将蒸汽设置为 MAX（强力）模式。将蒸汽喷头远离衣物，按住蒸汽开关 10 秒钟，以释放初始涌出的水滴。

问题	可能的原因	解决方法
蒸汽喷头出现脏水、褐色污渍或白色水垢，在衣物上留下污渍。	在水箱中添加了化学品或添加剂。	切勿在产品中使用化学品或添加剂。向水箱中注入水，让1满水箱的水通过生成蒸汽排出，以冲洗掉化学残留物。 对于在衣物上留下的污渍，请在自来水下冲洗掉所有污渍。 对于蒸汽喷头上的污渍，请用湿布擦去蒸汽喷头上的所有沉积物。
	根据您所在区域，水的硬度可能较高，导致水垢积聚会很快。	蒸汽熨烫后，确保水箱已倒空。建议将脱盐/去离子水(50%)与自来水(50%)组合使用。 在开始蒸汽熨烫时，请将蒸汽设置为 MAX (强力) 模式。将蒸汽喷头远离衣物，按住蒸汽开关10秒钟，以释放初始涌出的水滴。 对于在衣物上留下的污渍，请在自来水下冲洗掉所有污渍。 对于蒸汽喷头上的污渍，请用湿布擦去蒸汽喷头上的所有沉积物。



TC

問題	可能原因	方法
產品並未產生蒸氣。	蒸氣機未充分加熱 (電源按鈕閃爍)。	待產品加熱 90 秒。產品準備就緒可供使用時，指示燈會持續亮起。
	若產品超過 10 分鐘未使用，則已啟動自動斷電功能 (電源按鈕閃爍)。	按下電源按鈕並等候 90 秒，讓產品再次加熱。
	尚未按下蒸氣觸動器以釋出蒸氣。	按下蒸氣觸動器以啟動蒸氣功能。
	水箱內的水位過低或水箱未正確裝入。	為水箱加水並正確裝入。
	蒸氣鎖已啟動 10 分鐘。	蒸氣鎖功能包含自動釋放功能。再次輕按兩下蒸氣觸動器以啟動連續蒸氣功能 (請參閱)。
蒸氣機底座漏水。	未正確裝入水箱。	將水箱妥善裝入。
	水箱過滿。	將水加至 MAX 標記處。
無法啟動蒸氣鎖。	無法進入蒸氣鎖功能。	輕按兩下以啟動蒸氣鎖功能 (請參閱)。
將蒸氣噴頭放回固定座之後，蒸氣並未自動停止。	蒸氣鎖功能為啟動狀態。	按一下以關閉蒸氣鎖 (請參閱)。
熨燙板套潮濕，或熨燙時有水滴出現在衣服上。	長時間蒸氣熨燙後，蒸氣會凝結在熨燙板套上。	在進行收納之前，請先等熨燙板套完全乾燥。若熨燙板套已磨損，請予以更換。請向飛利浦授權之服務中心購買新的熨燙板套。
使用時，熨燙板會搖晃。	未正確安裝掛桿或未將熨燙板固定在掛桿上。	請參閱 瞭解正確的安裝方法。

問題	可能原因	方法
	熨燙板鎖未完全插入。	完全插入兩個熨燙板鎖，直到聽到咔嚓聲 (請參閱 )。
	熨燙板在垂直位置時並未完全固定。	請確定熨燙板傾斜壓桿位於鎖定位置後，再裝上掛桿 (請參閱 )。
熨燙板不可傾斜或用於水平位置。	熨燙板鎖未完全鎖上掛桿。	請確保熨燙板鎖位於鎖定位置 (請參閱 )。
	熨燙板傾斜壓桿未釋放。	務請將傾斜壓桿解鎖，讓熨燙板得以傾斜至想要的位置。 達到想要位置後，鎖定傾斜壓桿以固定熨燙板 (請參閱  / )
蒸氣噴頭會滴水，產品有時會發出汲水聲。	膠管中的蒸氣會凝結成水滴，並影響順暢的蒸氣流量。	拿起蒸氣噴頭，讓膠管以垂直方向伸直。 開始蒸氣熨燙時，將蒸氣設定為 MAX 模式。將蒸氣噴頭握持在遠離衣物的位置，並按下蒸氣觸動器 10 秒，以釋放最初滴出的水滴。
蒸氣噴頭會產生髒水、棕色汙漬或白碎屑，並在衣物上留下汙漬。	水箱加入化學物質或添加物。	請勿在產品中使用化學物質或添加物。在水箱加水，並讓水從 1 個滿水箱噴出，以沖掉殘留的化學物質。 針對衣物上的汙漬，請在流動的自來水下沖洗任何汙漬。 針對蒸氣噴頭的汙漬，請使用濕布擦拭蒸氣噴頭上的任何沉積物。

問題	可能原因	方法
	<p>視您的地點而定，水質硬度可能過高，因而快速累積水垢。</p>	<p>請確保在蒸氣熨燙後將水箱的水流光。建議使用軟化水/蒸餾水 (50%) 與自來水 (50%) 的混合水。</p> <p>開始蒸氣熨燙時，將蒸氣設定為 MAX 模式。將蒸氣噴頭握持在遠離衣物的位置，並按下蒸氣觸動器 10 秒，以釋放最初滴出的水滴。</p> <p>針對衣物上的污漬，請在流動的自來水下沖洗任何污漬。</p> <p>針對蒸氣噴頭的污漬，請使用濕布擦拭蒸氣噴頭上的任何沉積物。</p>





PHILIPS and the Philips Shield Emblem are registered trademarks of Koninklijke Philips N.V. and are used under license.

This product has been manufactured by and is sold under the responsibility of Versuni Holding B.V., and Versuni Holding B.V. is the warrantor in relation to this product.

2023 © Versuni Holding B.V.

4239.001.2021.3 (13/01/2023)

