

PHILIPS

AC2936/86

Original instruction by Philips



EN User manual 1

ZH-T 使用手冊 15



Contents

1	Your air purifier	2
	Product overview	2
	Controls overview	3
2	Getting started	3
	Installing the filter	3
	Wi-Fi indicator	4
	Wi-Fi connection	4
3	Using the air purifier	5
	Air quality light	5
	Turning On and Off	6
	Changing the mode setting	7
	Switching the display indicator	7
	Using the light on/off function	8
	Setting the child lock	8
	Checking the filter status	9
4	Cleaning and maintenance	9
	Cleaning the body of the air purifier	9
	Cleaning the particle sensor	9
	Cleaning the surface of the filter	10
	Replacing the filter	11
	Filter reset	12
5	Storage	12
6	Troubleshooting	12

1 Your air purifier

Congratulations on your purchase of air cleaner AC2936.
To fully benefit from the support that Philips offers, register your product at www.philips.com/welcome.

Product overview

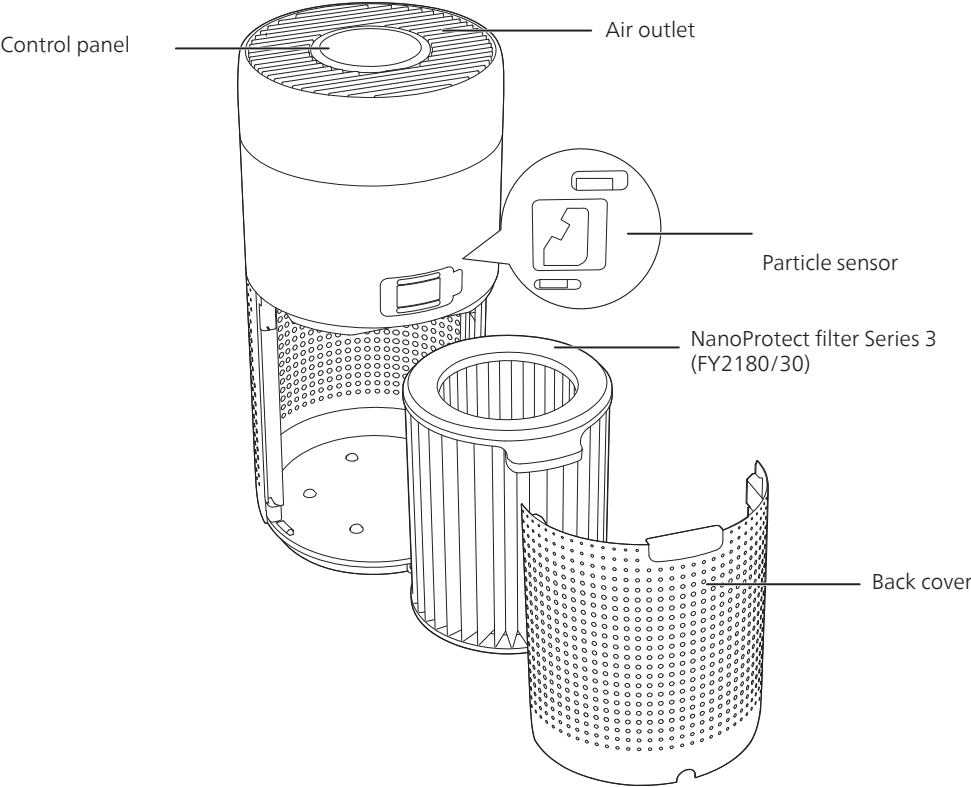

Controls overview

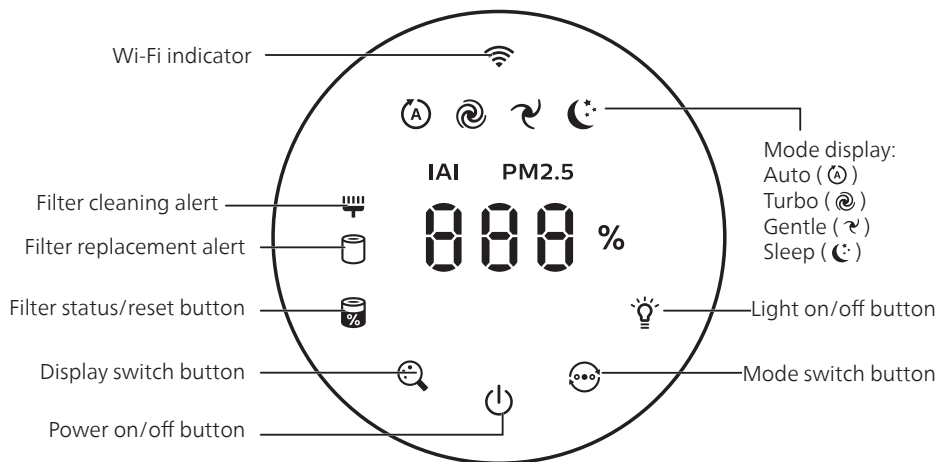

2 Getting started

Installing the filter

Note: Make sure the air purifier is unplugged from the electrical outlet before installing the filter.

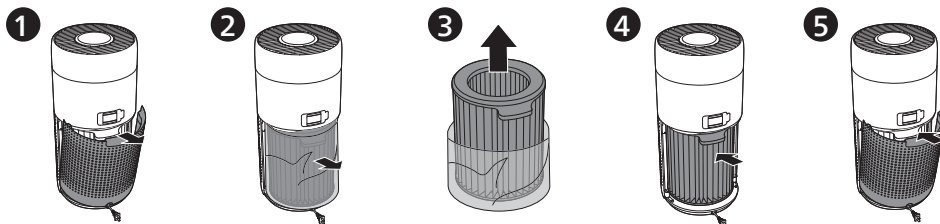

- 1 Pull the back cover and remove it from the appliance.
- 2 Pull the filter from the appliance.
- 3 Remove all packaging materials of the air purification filter.
- 4 Put the filter back into the appliance.
- 5 Reattach the back cover.

Wi-Fi indicator

Wi-Fi icon status	Wi-Fi connection status
Blink in orange	Connecting to the smartphone
Blink in white	Connecting to the router
Stable in white	Connected to the router
Off	Wi-Fi function disabled

Wi-Fi connection

Note:



- Corporate/Enterprise networks (e.g. certificates, network profiles) are not supported. We recommend setting up the Philips Air Purifiers on a dedicated network created for IoT devices or WPA2-Personal networks.
- Configuration details are provided in the Air+ app (e.g. Mac address) to help set-up on managed networks.

First time connection

- 1 Download and install the Philips **"Air+"** app from the **App Store** or **Google Play**.
- 2 Connect your smartphone or tablet to your Wi-Fi network.
- 3 Launch the **"Air+"** app and click on **"Connect a New Device"** or press the **"+"** button on the top of the screen. Follow the onscreen instructions to connect the air purifier to your network.



Reset the Wi-Fi connection

- 1 Touch  and  for 3 seconds until you hear a beep.
↳ The Wi-Fi indicator  blinks orange.
- 2 Follow the steps 3 in **"First time connection"** section.

Note:

- Enterprise/Additional webpage authentication networks are not supported.

3 Using the air purifier

Air quality light

After approximately 30 seconds, the particle sensor selects the color that corresponds to the surrounding air quality of airborne particles.

Note: The color of the air quality light is determined by the highest risk index among PM2.5, IAI and readings.

IAI refers to the level of indoor air allergen.

IAI level	Air quality light color	Air quality level
1-3	Blue	Good
4-6	Blue-purple	Fair
7-9	Purple-red	Poor
10-12	Red	Very poor

PM2.5 refers to airborne particle pollutants smaller than 2.5 micrometers.

PM2.5 level	Air quality light color	Air quality level
≤12	Blue	Good
13-35	Blue-purple	Fair
36-55	Purple-red	Poor
>55	Red	Very poor

Turning On and Off

Note:

- Put the plug of the air purifier in the power socket.
- If the purifier stays connected to the electrical outlet after turning OFF, the air purifier will operate under the previous settings when turned ON again.

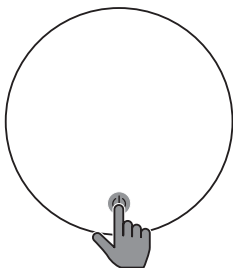

» Touch  to switch on the air purifier.

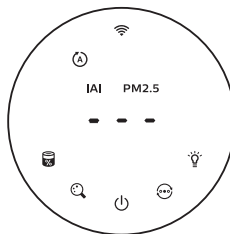

» The “- - - -” displays on the screen during warming up. Then the air purifier shows the IAI/PM2.5 level after measuring the air quality.



» The air purifier operates in the auto mode with IAI displayed on the screen.

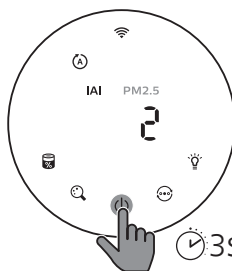

» Touch and hold the  button for 3 seconds to switch off the air purifier.

Changing the mode setting

You can choose Auto mode, Turbo mode, Gentle mode or the Sleep mode by touching the  button.

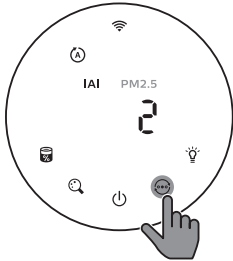

Auto mode (Ⓐ): The air purifier automatically adjusts the fan speed in accordance with the ambient air quality.



Turbo mode (Ⓐ): The air purifier operates on the highest speed.

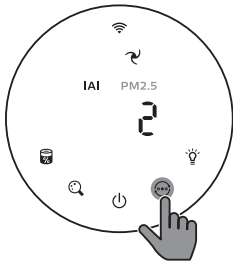

Gentle mode (Ⓐ): The air purifier operates at a low speed.

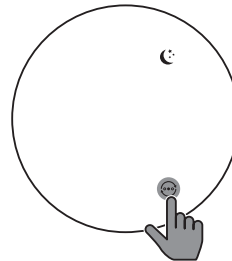

Sleep mode (☾): The air purifier operates quietly at a low speed. After 3 seconds, the screen lights off.

Switching the display indicator

Note:

- The appliance display IAI level by default.



Using the light on/off function

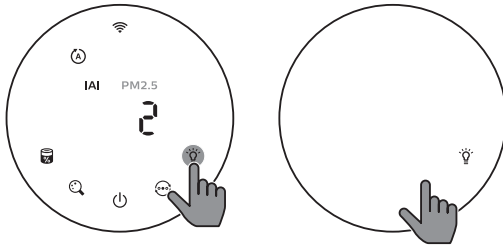

You can touch the light on/off button  manually to turn off all lights and the control panel. Touch any button to wake up all lights.







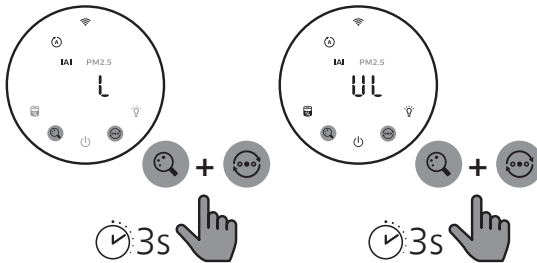

With the light sensor:

- The control panel can automatically turn on, turn off or dim according to the ambient light.
- The control panel will be off or dim when the ambient light is dark.

You can touch any button to wake up all lights. If no further operation, all lights will be off or dim again to match with the ambient light.

Setting the child lock



- 1 Touch and hold  and  button for 3 seconds to activate child lock.
 - ↳  displays on the screen, only  and  button light up.
 - ↳ After 3 seconds, the screen goes back to normal display.
- 2 Touch and hold  and  button for 3 seconds again to deactivate child lock.
 - ↳  displays on the screen for 3 seconds and goes back to normal display.
 - ↳ All buttons light up.

Checking the filter status

- Touch the filter status check/reset  button to check the filter service life status.

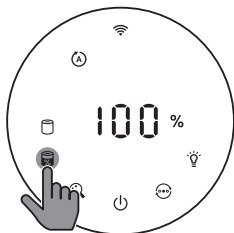

Icon color	Display (%)
Blue	16-100
Blue-purple	9-15
Purple-red	4-8
Red	0-3

Note: The appliance goes back to normal display if no operations after 3 seconds.

4 Cleaning and maintenance

Note:

- Do not attempt to clean the particle sensor with a vacuum cleaner.
- Switch off the air purifier and unplug from the power socket before following action.

Cleaning the body of the air purifier

Use a soft, dry cloth to clean both the interior and exterior of the air purifier and the air outlet.

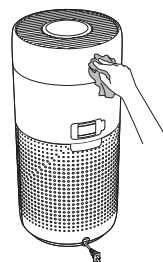

Cleaning the particle sensor

Clean the particle sensor every 2 months for optimal functioning of the appliance.

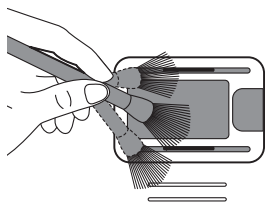

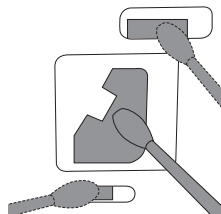

- 1 Clean the particle sensor inlet and outlet with a soft brush.

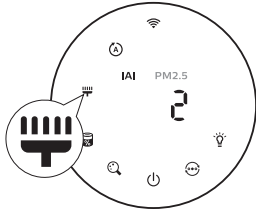

- 2 Clean the particle sensor with a damp cotton swab. Dry all parts thoroughly with a dry cotton swab.

Cleaning the surface of the filter



Clean the surface of filter with vacuum cleaner when the filter cleaning alert  display on the screen.



1 Pull the back cover and remove it from the appliance.

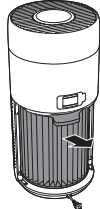

2 Pull the filter from the appliance.

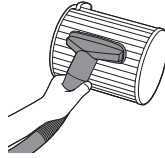

3 Clean the surface of the filter with a vacuum cleaner.



4 Put the filter back into the appliance.

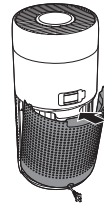

5 Reattach the back cover.

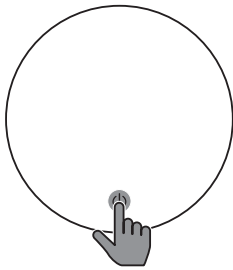

6 Touch the  button to switch on the appliance.

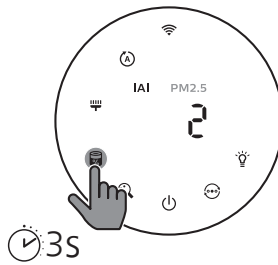

7 Touch and hold the filter status check/reset button  for 3 seconds to reset the filter cleaning time.

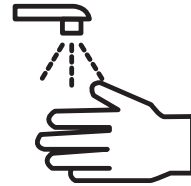

8 Wash your hands thoroughly after cleaning the filter.

Replacing the filter

Note:

- The filter is not washable or reusable.
- Do not smell the filter as it has collected pollutants from the air.

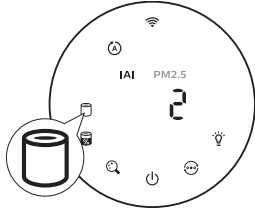

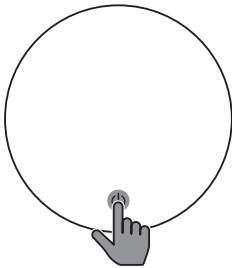

When the filter need to be replaced, the filter replacement alert  lights up red.

- 1 Replace the filter with Philips NanoProtect filter Series 3 (FY2180/30) , Please follow the step of Chapter "Installing the filter".

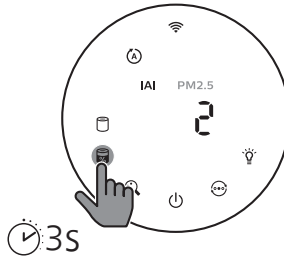

- 2 Touch the  button to switch on the appliance.



- 3 Touch and hold the filter status check/reset button  for 3 seconds to reset the filter replacement time.

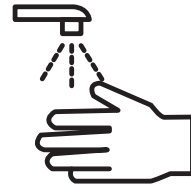

- 4 Wash your hands thoroughly after replacing the filter.

Filter reset

You can also replace the filter before filter replacement alert () displays on the screen. After replacing a filter, you need to reset the filter lifetime counter manually.

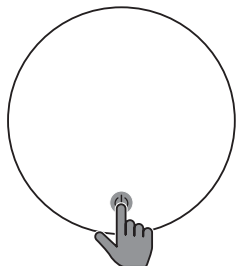

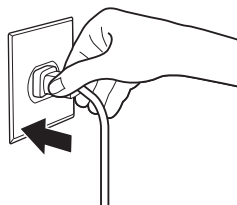

- 1 Touch the power  button for 3 seconds to turn off the appliance and unplug from power socket.

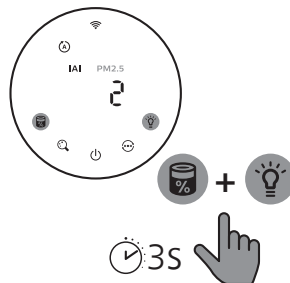

- 2 Put the power plug in the power socket.



- 3 Within 15 seconds after power on, touch and hold  and  button for 3 seconds to reset the filter lifetime counter.

5 Storage

- 1 Turn off the air purifier and unplug from the power socket.
- 2 Clean the air purifier, particle sensor and the surface of the filter (see the chapter "Cleaning and maintenance").
- 3 Let all parts air dry thoroughly before storing.
- 4 Wrap the filter in air tight plastic bags.
- 5 Store the air purifier, filter in a cool, dry location.
- 6 Always thoroughly wash hands after handling filters.

6 Troubleshooting

This chapter summarizes the most common problems you could encounter with the appliance. If you are unable to solve the problem with the information below, contact the Consumer Care Center in your country.

Problem	Possible solution
The appliance does not work properly.	<ul style="list-style-type: none">• The filter replacement alert has been on continuously but you have not replaced the corresponding filter. As a result, the appliance is now locked. In this case, replace the filter and long press  to reset the filter lifetime counter.
The airflow that comes out of the air outlet is significantly weaker than before.	<ul style="list-style-type: none">• The surface of the filter is dirty. Clean the surface of the filter (see the chapter "Cleaning and maintenance").

Problem	Possible solution
The air quality does not improve, even though the appliance has been operating for a long time.	<ul style="list-style-type: none"> • Check if the packing material is removed from the filter. • The filter has not been placed in the appliance. Make sure that the filter (FY2180/30) is properly installed. • The particle sensor is wet. The humidity level in your room is high and causes condensation. Make sure that the particle sensor is clean and dry (see the chapter "Cleaning and maintenance"). • Room size is large or the outdoor air quality is poor. For optimum purification performance, please close the doors and windows when operating the air purifier. • There are indoor pollution resources. For instances, smoking, cooking, incense, perfume or alcohol. • Filter reaches the end of life. Replace the filter with a new one.
The color of the air quality light always stays the same.	<ul style="list-style-type: none"> • The particle sensor is dirty. Clean the particle sensor (see the chapter "Cleaning and maintenance").
The appliance produces a strange smell.	<ul style="list-style-type: none"> • The first few times you use the appliance, it may produce a plastic smell. This is normal. However, if the appliance produces a burnt smell even if removing filters, contact your Philips dealer or an authorized Philips service center. The filter may produce smell after being used for a while because of the absorption of indoor gases. It's recommended that you reactivate the filter by putting it in direct sunlight for repeated use. If odor still exists, replace the filter.
The appliance is extra loud.	<ul style="list-style-type: none"> • It's normal if the appliance runs at the Turbo mode. • In the Auto mode, if the appliance is too loud, maybe the appliance runs at high speed because air quality becomes worse, or your personalized setting in App triggers a higher fan speed. You can choose the Sleep mode, or change the settings in the app. • If anything drops into air outlet, it may also cause abnormal loud sound. Immediate turn off appliance, turn appliance upside down, to get foreign objectives out of appliance. • If there is abnormal sound, contact the Consumer Care Center in your country.
The appliance still indicates that I need to replace a filter, but I already did.	<ul style="list-style-type: none"> • Perhaps you did not reset the filter lifetime counter. Switch on the appliance. Then touch and hold the reset button () for 3 seconds.
Error code "E1" displays on the screen.	<ul style="list-style-type: none"> • The motor has malfunctions. Contact the Consumer Care Center in your country.

Problem	Possible solution
<p>The Wi-Fi setup is not successful.</p>	<ul style="list-style-type: none"> • If the router your purifier is connected to is dual – band and currently it is not connecting to a 2.4GHz network, please switch to another band of the same router (2.4GHz) and try to pair your purifier again. 5GHz networks are not supported. If your purifier is connected to a dual – band router, please switch to the 2.4GHz network of the router and try to pair your purifier again. • Web authentication networks are not supported.Public Wi-Fi such as office or hotel networks are not supported. • Check if the purifier is within range of the Wi-Fi router. You can try to locate the air purifier closer to the Wi-Fi router. • Check if the Wi-Fi password is correct. The password is case-sensitive. • Retry the setup with the instructions in section “Reset the Wi-Fi connection”. • Keep the appliance away from other electronic devices that may cause interferences. • Check if the mobile device is in airplane mode. Make sure to have the airplane mode deactivated when connecting to the Wi-Fi network. • If the Wi-Fi pairing fails after trying several times, please turn of the cellular data on your smartphone in the Settings section and start the pairing again. • If the Wi-Fi icon on your purifier’s display is in stable white but without seeing the purifier in your app, click on “Connect a New Device” and add the purifier from the local list on “Begin setup” page. • Consult the help section in the app for extensive and up-to-date troubleshooting tips.

內容

1	您的空氣清淨機	16
	產品概覽	16
	控制項概覽	17
2	快速入門	17
	安裝濾網	17
	Wi-Fi 指示燈	18
	Wi-Fi 連線	18
3	使用空氣清淨機	19
	空氣品質指示燈	19
	開啟和關閉電源	20
	變更模式設定	21
	切換顯示指示燈	21
	使用開/關燈按鈕	22
	設定兒童鎖	22
	檢查濾網狀態	23
4	清潔與維護	23
	清潔空氣清淨機的機體	23
	清潔微粒感測器	23
	清潔濾網表面	24
	更換濾網	25
	濾網重設	26
5	收納	26
6	疑難排解	26

1 您的空氣清淨機

恭喜您購買空氣清淨機 AC2936。

若要獲得飛利浦提供的完整支援，請註冊您的產品：www.philips.com/welcome。

產品概覽

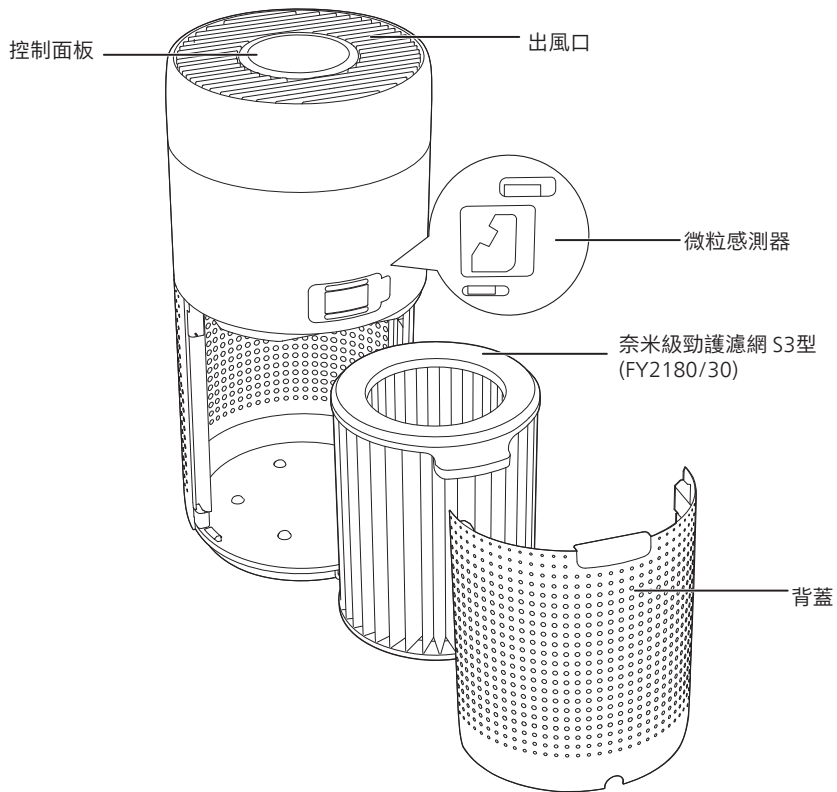

控制項概覽

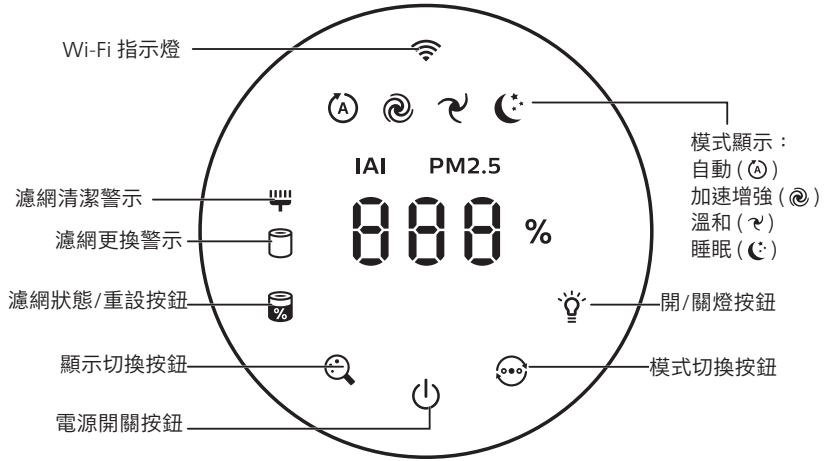

2 快速入門

安裝濾網

備註：請確定已從電源插座拔除空氣清淨機的電源插頭後，再安裝濾網。

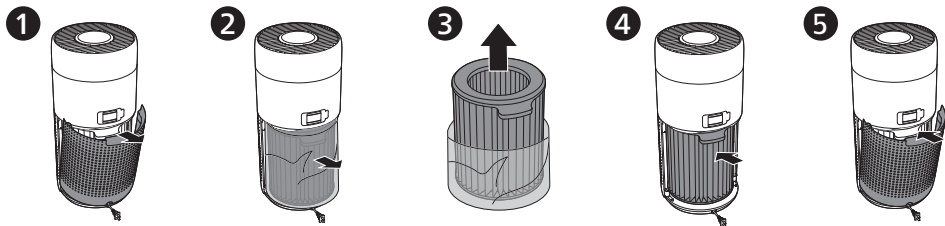

- 1 拉動背蓋並將其從產品上取下。
- 2 從產品拉出濾網。
- 3 拆下空氣淨化濾網的所有包裝材料。
- 4 將濾網裝回產品。
- 5 將背蓋重新裝回。

Wi-Fi 指示燈

Wi-Fi 圖示狀態	Wi-Fi 連線狀態
閃爍橘燈	正在連線至智慧型手機
閃爍白燈	正在連線至路由器
穩定白燈	已連線至路由器
熄滅	Wi-Fi 功能已停用

Wi-Fi 連線

備註：



- 不支援公司/企業網路 (如憑證、網路設定檔)。建議於專為 IoT 裝置建立的專用網路或 WPA2-Personal 網路上設定飛利浦空氣清淨機。
- 如需在受管理網路上協助設定，Air+ 應用程式有提供組態詳細資料 (如 Mac 位址)。

首次連線

- 1 下載並安裝飛利浦「Air+」應用程式，下載位置如下：**App Store** 或 **Google Play**。
- 2 將您的智慧型手機或平板電腦連線至 Wi-Fi 網路。
- 3 啟動「Air+」應用程式，並按一下「**連接新裝置**」或按下畫面上方的「+」按鈕。依照螢幕指示將空氣清淨機連接至您的網路。



重設 Wi-Fi 連線

- 1 按下  和  3 秒鐘，直到聽到嗶聲。
↳ Wi-Fi 指示燈  會閃爍橘光。
- 2 請依照「**首次連線**」一節的步驟 3 操作。

備註：

- 不支援企業/額外網頁驗證網路。

3 使用空氣清淨機

空氣品質指示燈

在約 30 秒後，微粒感測器會選擇符合周遭空氣粒子品質的相應顏色。

備註：空氣品質指示燈的顏色取決於 PM2.5、IAI 及讀數間的最高風險指數。

IAI 是指室內空氣過敏原的等級。

IAI 等級	空氣品質指示燈顏色	空氣品質等級
1-3	藍色	良好
4-6	藍色 - 紫色	普通
7-9	紫色 - 紅色	不良
10-12	紅色	非常不良

PM2.5 是指小於 2.5 微米的空氣微粒汙染物。

PM2.5 等級	空氣品質指示燈顏色	空氣品質等級
≤12	藍色	良好
13-35	藍色 - 紫色	普通
36-55	紫色 - 紅色	不良
>55	紅色	非常不良

開啟和關閉電源

備註：

- 將空氣清淨機的插頭插入電源插座。
- 如果清淨機在關閉之後保持連接至電源插座，則當空氣清淨機再次開啟時，會以先前的設定運作。

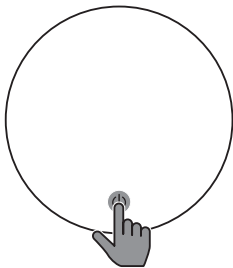

- 按下  即可開啟空氣清淨機的電源。

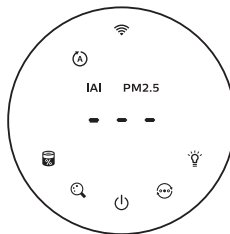

- 暖機期間螢幕上會顯示「----」。接著空氣清淨機會在測量空氣品質後顯示 IAI/PM2.5 等級。



- 空氣清淨機會以自動模式運作，螢幕上會顯示 IAI。

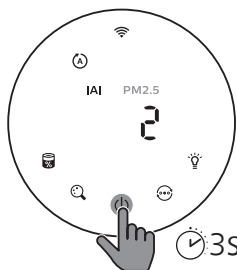

- 按住  按鈕 3 秒鐘即可關閉空氣清淨機的電源。

變更模式設定

按下  按鈕即可選擇自動模式、加速增強模式、溫和模式或睡眠模式。

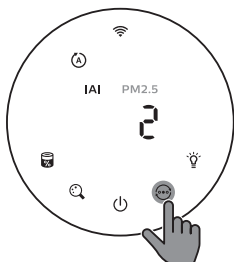

自動模式 (A)：空氣清淨機會依照周遭空氣品質自動調整風扇速度。

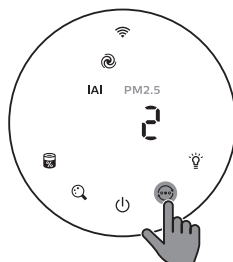

加速增強模式 (⊙)：空氣清淨機會以最高速度運作。

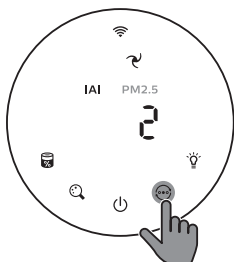

溫和模式 (ㄨ)：空氣清淨機會以低速運作。

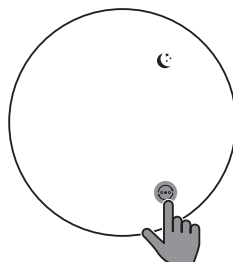

睡眠模式 (☾)：空氣清淨機會以低速安靜地運作。3 秒後，螢幕燈光會熄滅。

切換顯示指示燈

備註：

- 產品預設會顯示 IAI 等級。



使用開/關燈按鈕

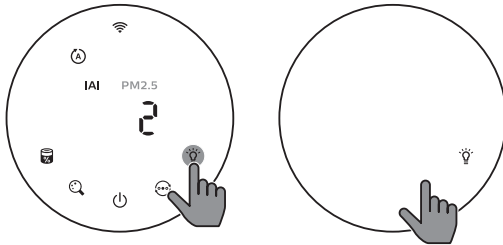

您可以手動按下開/關燈按鈕  來關閉所有燈號和控制面板。按下任何按鈕即可喚醒所有燈號。







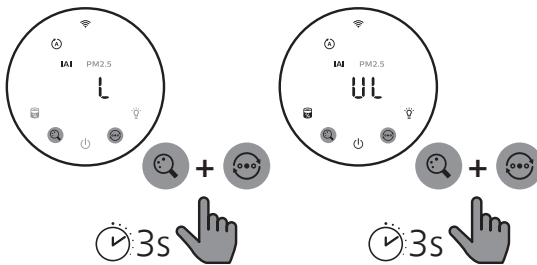

使用光線感應器：

- 控制面板會根據環境光線自動開啟、關閉或調暗。
- 當環境光線變暗時，控制面板會關閉或變暗。

您可以按下任何按鈕以喚醒所有燈號。如果沒有進一步的操作，所有燈號將會熄滅或變暗，以配合環境光線。

設定兒童鎖



- 1 按住  及  按鈕 3 秒鐘，可啟動保護鎖。
 - ↳ 螢幕顯示 ，僅  及  按鈕亮起。
 - ↳ 3 秒鐘後，螢幕即返回正常顯示。
- 2 再次按住  及  按鈕 3 秒鐘，可停用保護鎖。
 - ↳ 螢幕顯示  3 秒鐘後，隨即返回正常顯示。
 - ↳ 所有按鈕亮起。

檢查濾網狀態

- 按下濾網狀態檢查/重設  按鈕，以檢查濾網使用壽命狀態。

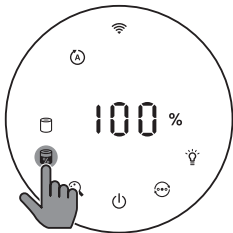

圖示顏色	顯示 (%)
藍色	16-100
藍色 - 紫色	9-15
紫色 - 紅色	4-8
紅色	0-3

備註：如果 3 秒後沒有任何操作，產品會返回正常顯示。

4 清潔與維護

備註：

- 請勿試圖以吸塵器清理微粒感測器。
- 進行以下操作前，請關閉空氣清淨機的電源，並從電源插座拔掉插頭。

清潔空氣清淨機的機體

使用柔軟乾布清潔空氣清淨機與出風口的內外部。

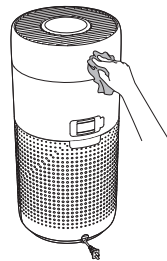

清潔微粒感測器

每 2 個月清潔一次微粒感測器，可確保產品發揮最佳效果。

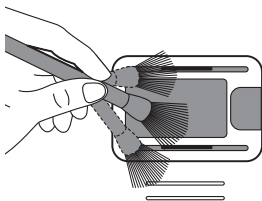

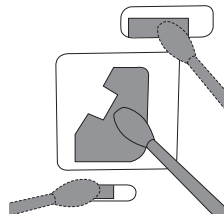

- 1 請使用軟刷來清潔微粒感測器的進風口及出風口。

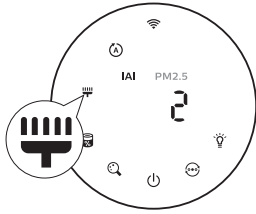

- 2 使用濕棉棒清潔微粒感測器。使用乾棉棒擦乾所有零件。

清潔濾網表面



當螢幕顯示濾網清潔警示  時，請使用吸塵器清潔濾網表面。



1 拉動背蓋並將其從產品上取下。



2 從產品拉出濾網。

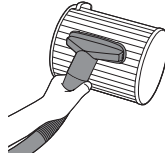

3 使用吸塵器清潔濾網表面。



4 將濾網裝回產品。

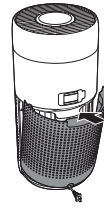

5 將背蓋重新裝回。

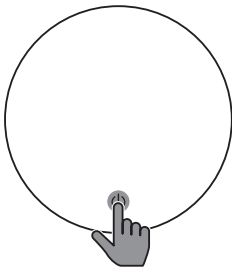

6 按下  按鈕以開啟產品電源。

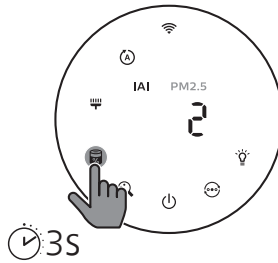

7 按住濾網狀態檢查/重設按鈕  3 秒以重設濾網清潔時間。

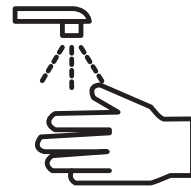



8 清潔濾網後請徹底清洗雙手。

更換濾網

備註：

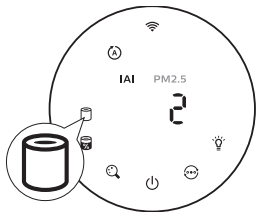
- 濾網不可水洗或重複使用。
- 請勿嗅聞濾網，因為它收集了空氣中的污染物。



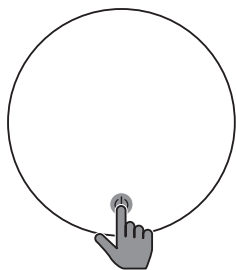

需要更換濾網時，濾網更換警示  會亮起紅燈。

- 1 請以飛利浦奈米級勁護濾網 S3型 (FY2180/30) 更換濾網，請依照「安裝濾網」單元的步驟操作。

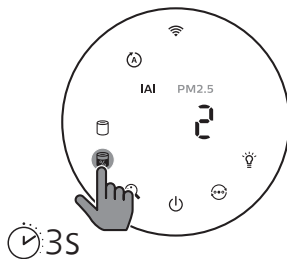

- 2 按下  按鈕以開啟產品電源。



- 3 按住濾網狀態檢查/重設按鈕  3 秒以重設濾網更換時間。

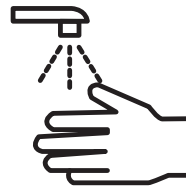

- 4 更換濾網後請徹底清洗雙手。

濾網重設

您也可以螢幕上出現濾網更換警示 () 之前更換濾網。更換濾網後，您需要手動重設濾網使用壽命計時器。

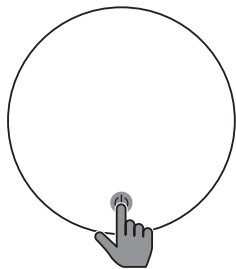

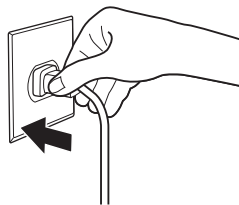

1 按住電源  按鈕 3 秒鐘，關閉產品電源，並從電源插座拔除插頭。

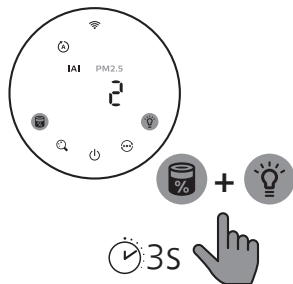

2 將電源插頭插入插座。



3 電源開啟後 15 秒內，按住  和  按鈕 3 秒鐘，可重設濾網使用壽命計時器。

5 收納

- 1 關閉空氣清淨機的電源，從電源插座拔掉插頭。
- 2 清潔空氣清淨機、微粒感測器和濾網表面 (請參閱「清潔與維護」單元)。
- 3 收納之前，請確保所有零件徹底風乾。
- 4 將濾網包在氣密塑膠袋中。
- 5 將空氣清淨機和濾網存放在涼爽乾燥處。
- 6 接觸過濾網後，請務必徹底清洗雙手。

6 疑難排解

本單元概述您使用本產品時可能遇到的最常見問題。如果您無法利用以下資訊解決您遇到的問題，請聯絡您所在國家/地區的客戶服務中心。

問題	可能的解決方法
產品無法正常運作。	<ul style="list-style-type: none">• 濾網更換警示持續亮起，但未更換相應濾網。結果導致產品鎖定。在此情況下，請更換濾網並長按  即可重設濾網使用壽命計時器。
出風口流出的風速比之前慢很多。	<ul style="list-style-type: none">• 濾網表面髒汙。清潔濾網表面 (請參閱「清潔與維護」單元)。

問題	可能的解決方法
即使產品已經長時間運作，空氣品質仍未獲得改善。	<ul style="list-style-type: none"> 請檢查是否已拆下濾網的包裝材料。 濾網尚未裝入產品中。請確認濾網 (FY2180/30) 已正確安裝。 微粒感測器潮溼。室內的濕度很高，造成水珠凝結。請確認微粒感測器乾淨且乾燥 (請參閱「清潔與維護」單元)。 房間很大，或戶外空氣品質不佳。為獲得最佳淨化效能，請在操作空氣清淨機時關閉門窗。 有室內汙染源。例如吸煙、烹飪、薰香、使用香水或酒精。 濾網使用壽命已盡。更換新的濾網。
空氣品質指示燈的顏色一直維持不變。	<ul style="list-style-type: none"> 微粒感測器髒污。清潔微粒感測器 (請參閱「清潔與維護」單元)。
使用產品時發出異味。	<ul style="list-style-type: none"> 使用本產品的前幾分鐘，可能會產生塑膠味。此為正常現象。然而，如果取下濾網後產品依然發出焦味，請聯絡您的飛利浦經銷商或授權的飛利浦服務中心。使用一段時間之後，濾網可能會因為吸收室內氣體而產生異味。建議將濾網拿到陽光下曝曬以供重複使用。如果異味仍然存在，請更換濾網。
產品噪音太大。	<ul style="list-style-type: none"> 產品以加速增強模式運作時，這是正常現象。 在自動模式中，如果產品聲音太大，可能是因為空氣品質變差使得產品以高速運轉，或是應用程式的個人化設定觸動風扇速度提高。您可以選擇睡眠模式，或變更應用程式中的設定。 如果有任何東西掉入出風口，可能也會造成異常大的聲響。立即關閉產品電源，將產品上下顛倒放置，從產品中取出異物。 如果出現異常聲音，請聯絡所在國家/地區的客戶服務中心。
產品不斷指示需更換濾網，但濾網已經更換了。	<ul style="list-style-type: none"> 您或許未重設濾網使用壽命計時器。開啟產品。然後按住重設按鈕 (🔄) 3 秒鐘。
螢幕顯示「E1」錯誤代碼。	<ul style="list-style-type: none"> 馬達故障。請聯絡您所在國家/地區的客戶服務中心。
Wi-Fi 設定不成功。	<ul style="list-style-type: none"> 如果清淨機連接的路由器為雙波段，且目前並未連接至 2.4GHz 網路，請切換到相同路由器的另一個波段 (2.4GHz) 並嘗試再次配對您的清淨機。不支援 5GHz 網路。如果清淨機連接至雙頻路由器，請切換至路由器的 2.4GHz 網路，然後嘗試再次配對清淨機。 不支援 Web 驗證網路。不支援公共 Wi-Fi，例如辦公室或飯店網路。 檢查清淨機是否位於 Wi-Fi 路由器的範圍內。您可以嘗試將空氣清淨機移近 Wi-Fi 路由器。 檢查 Wi-Fi 密碼是否正確。密碼需區分大小寫。 請依照「重設 Wi-Fi 連線」一節的指示重試設定。 請讓本產品盡量遠離可能造成干擾的其他電子裝置。 檢查行動裝置是否處於飛行模式。連接至 Wi-Fi 網路時，請務必先停用飛行模式。 如果嘗試數次後 Wi-Fi 配對失敗，請在「設定」部分關閉智慧型手機的行動數據，然後重新開始配對。 如果清淨機螢幕上的 Wi-Fi 圖示為持續亮起的白色，但在應用程式中沒看到清淨機，請按一下「連接新裝置」，並從「開始設定」頁面的本機清單新增清淨機。 請參閱應用程式的說明一節，以深入掌握最新的疑難排解秘訣。

設備名稱：飛利浦空氣清淨機，型號（型式）：AC2936/86 Equipment name Type designation (Type)						
單元 Unit	限用物質及其化學符號 Restricted substances and its chemical symbols					
	鉛 Lead (Pb)	汞 Mercury (Hg)	鎘 Cadmium (Cd)	六價鉻 Hexavalent chromium (Cr ⁺⁶)	多溴聯苯 Polybrominated biphenyls (PBB)	多溴二苯醚 Polybrominated diphenyl ethers (PBDE)
電源線組	○	○	○	○	○	○
塑膠外殼	○	○	○	○	○	○
電源板組件	-	○	○	○	○	○
電機組件	-	○	○	○	○	○
顯示燈板組件	○	○	○	○	○	○
傳感器板組件	-	○	○	○	○	○
<p>備考1：“超出 0.1 wt %”及“超出 0.01 wt %”係指限用物質之百分比含量超出百分比含量基準值。 Note 1: “Exceeding 0.1 wt %” and “exceeding 0.01 wt %” indicate that the percentage content of the restricted substance exceeds the reference percentage value of presence condition.</p> <p>備考2：“○”係指該項限用物質之百分比含量未超出百分比含量基準值。 Note 2: “○” indicates that the percentage content of the restricted substance does not exceed the percentage of reference value of presence.</p> <p>備考3：“-”係指該項限用物質為排除項目。 Note 3: The “-” indicates that the restricted substance corresponds to the exemption.</p>						

NCC 警語：

取得審驗證明之低功率射頻器材，非經核准，公司、商號或使用者均不得擅自變更頻率、加大功率或變更原設計之特性及功能。低功率射頻器材之使用不得影響飛航安全及干擾合法通信；經發現有干擾現象時，應立即停用，並改善至無干擾時方得繼續使用。前述合法通信，指依電信管理法規定作業之無線電通信。低功率射頻器材須忍受合法通信或工業、科學及醫療用電波輻射性電機設備之干擾。





© 2022 Philips Domestic Appliances Holding B.V.

All rights reserved.

Tussendiepen 4 a, 9206AD Drachten, The Netherlands

3000.095. 8812.1 (23/06/2022)

