

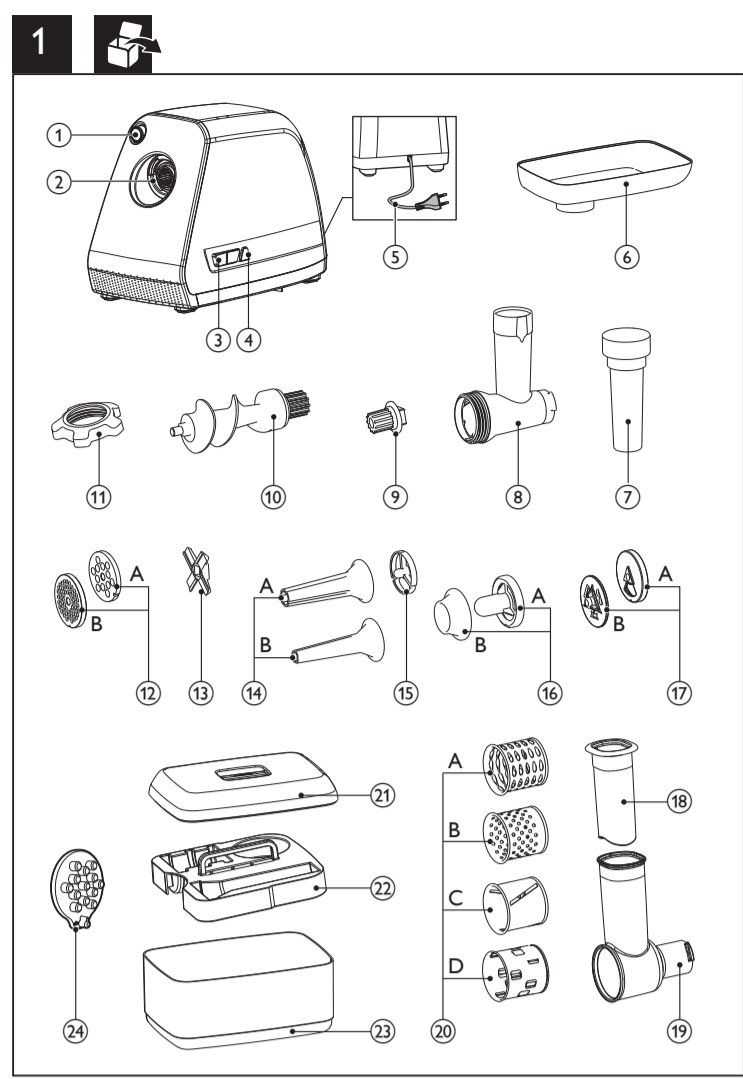

HR2726
HR2727
HR2728
HR2729
HR2526

| | | | |
|----|------------------|----|-----------------|
| EN | User manual | FR | Mode d'emploi |
| DA | Brugervejledning | NO | Brukerhåndbok |
| DE | Benutzerhandbuch | SV | Användarhandbok |
| FI | Käyttöopas | | |

PHILIPS

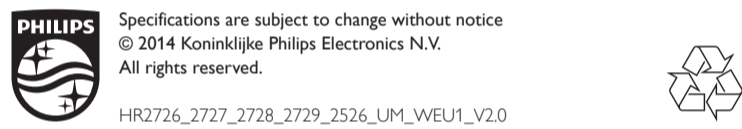
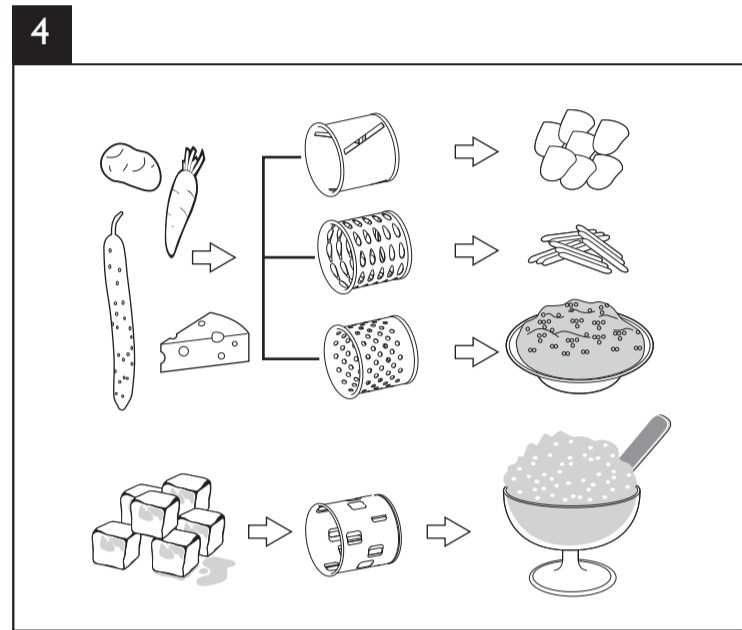

| | ✓ | ✗ | ✓ | ✗ | ✓ |
|--------------------------------|---|---|---|---|---|
| HR2726, HR2526, HR2727, HR2728 | | | | | |
| HR2726, 2727, 2526 | ✓ | ✓ | ✓ | ✓ | ✓ |
| HR2728 | | | | | |
| HR2726, 2729, 2526 | ✓ | ✓ | ✓ | ✓ | ✓ |
| HR2727, HR2728 | | | | | |
| HR2728, 2729, 2526 | ✓ | ✓ | ✓ | ✓ | ✓ |
| HR2728 | | | | | |
| HR2728, 2729, 2526 | ✓ | ✓ | ✓ | ✓ | ✓ |

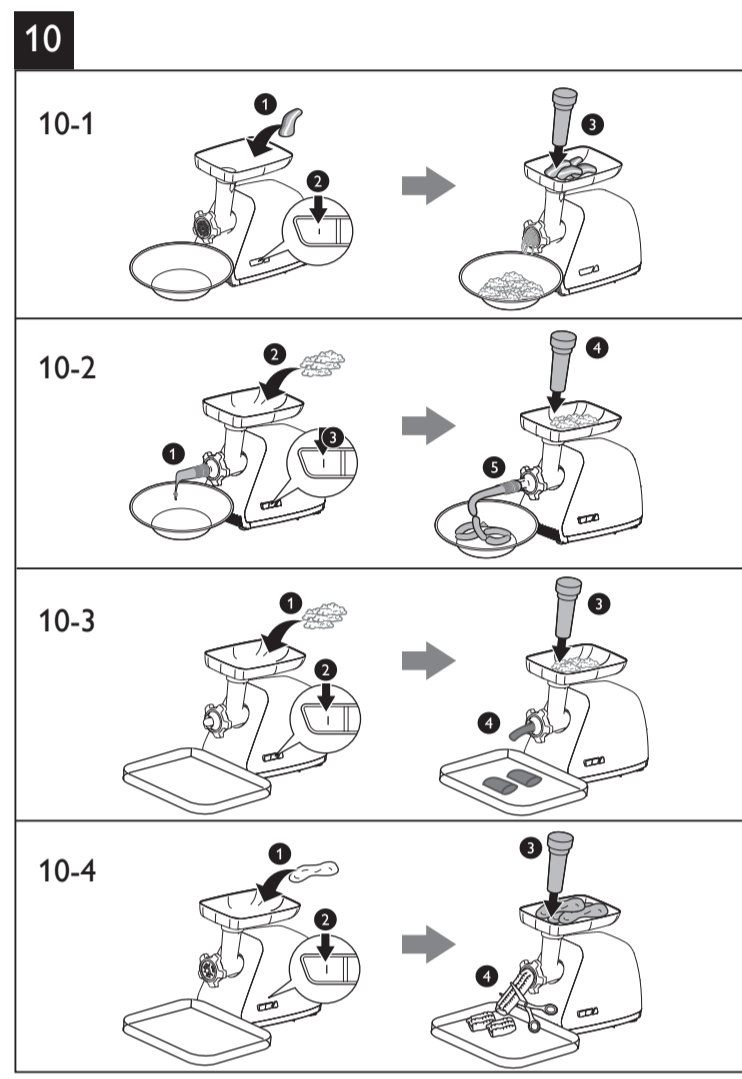
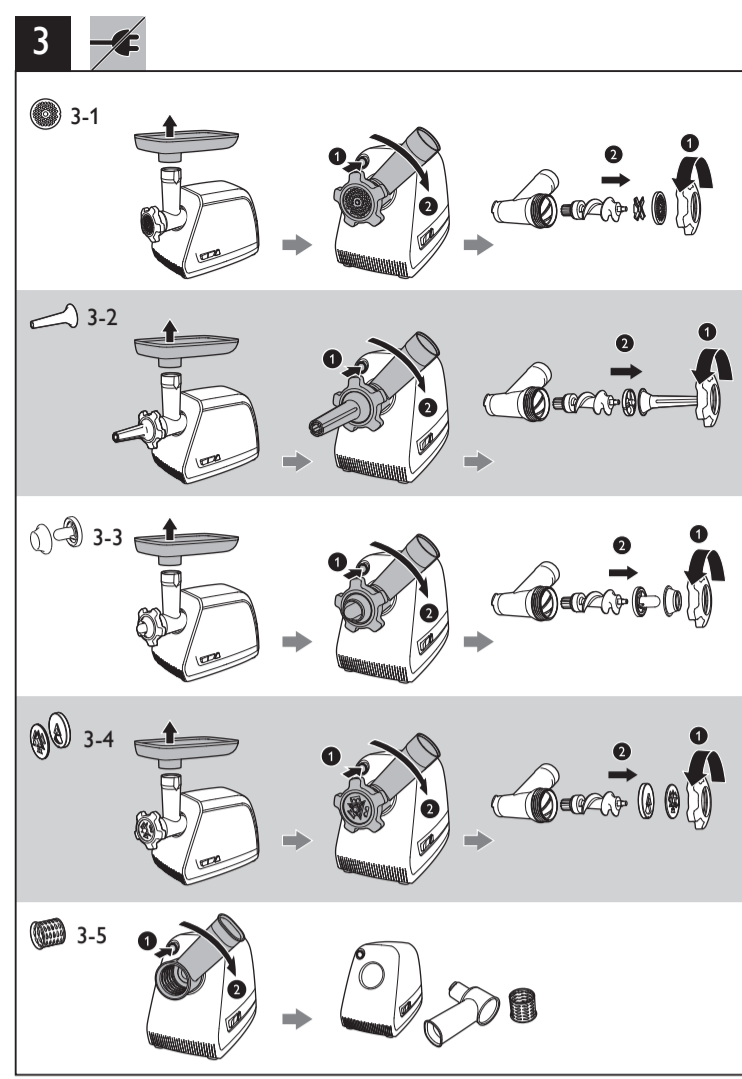
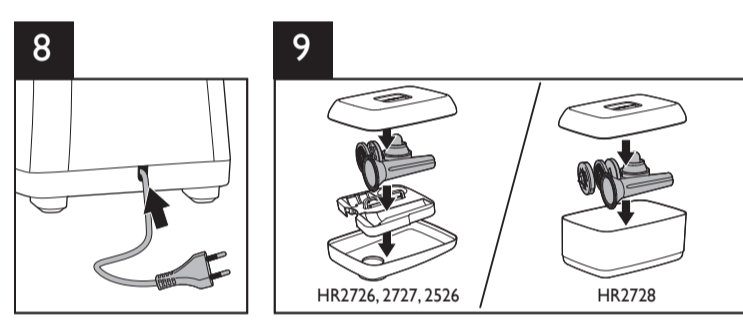
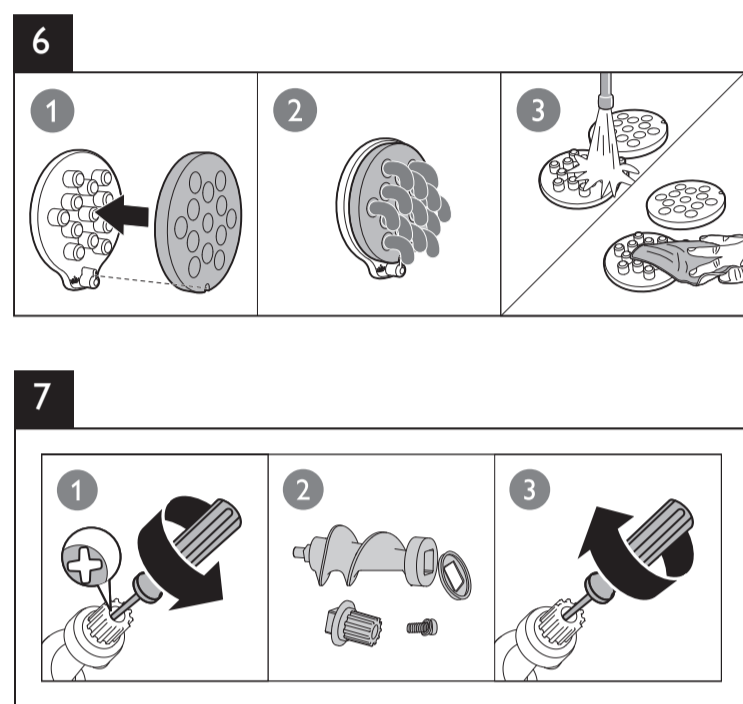
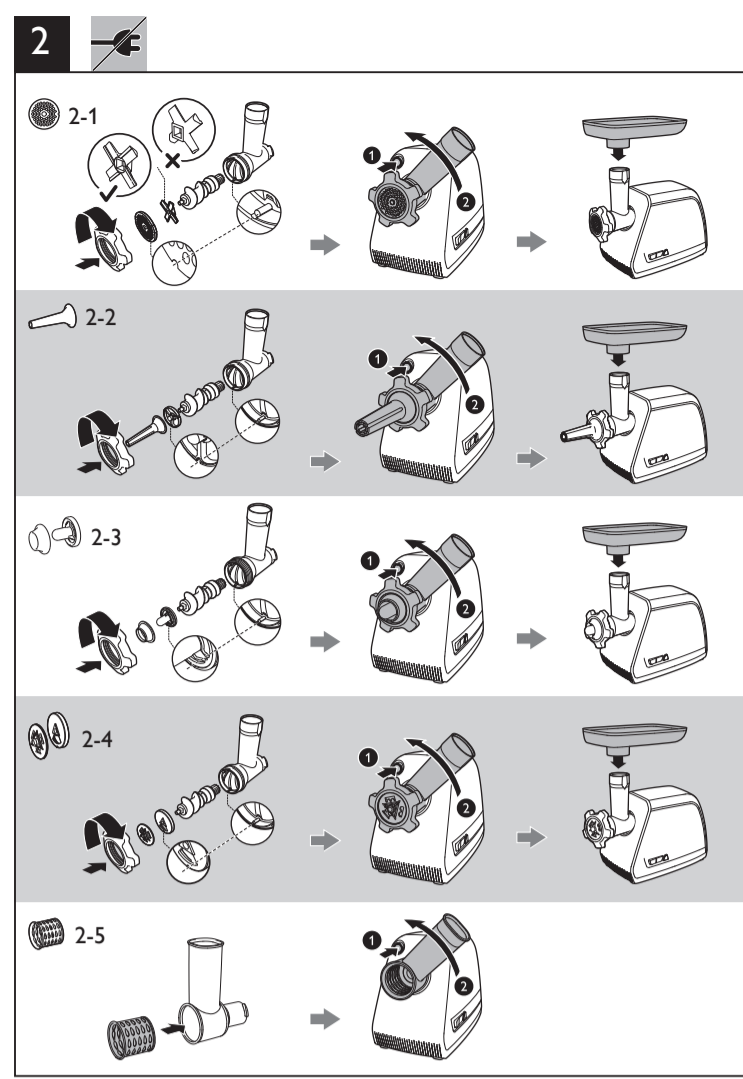

English

1 Important

Read these instructions for use carefully before using the appliance and save them for future reference.

Danger

- Do not immerse the motor unit in water nor rinse it under the tap.
- Do not connect the appliance to a timer switch.

Warning

- Before you connect the appliance to the power, make sure that the voltage indicated on the bottom of the appliance corresponds to the local power voltage.
- If the power cord, the plug, or other parts are damaged, do not use the appliance.
- If the power cord is damaged, you must have it replaced by Philips, a service center authorized by Philips, or similarly qualified person to avoid a hazard.

- This appliance is not intended for use by persons (including children) with reduced physical, sensory or mental capabilities, or lack of experience and knowledge, unless they have been given supervision or instruction concerning use of the appliance by a person responsible for their safety.
- For their safety, do not allow children to play with the appliance.
- Be very careful when you handle the cutter, especially when you remove it from the worm shaft and during cleaning. The cutting edges are very sharp!
- Before you remove any accessory, switch the appliance off and unplug it.
- Do not use your fingers or an object (e.g. a spatula) to push ingredients into the hopper while the appliance is running. Only the pushers are to be used for this purpose.
- Do not insert your fingers in the metal drum while the appliance is running.

Caution

- The appliance is intended for household use only.
- Before you connect the appliance to the mains, make sure that the appliance is assembled correctly.
- Never use any accessories or parts from other manufacturers or that Philips does not specifically recommend. If you use such accessories or parts, your guarantee becomes invalid.
- Always switch the appliance off by pressing the o / i button.
- Do not let the appliance run unattended.
- Do not exceed the maximum operating time of 10 minutes at all applications.
- Do not switch the appliance to Reverse mode when using the plastic hopper.
- Noise level: Lc = 87 dB [A]

Safety system

This appliance is equipped with overheat protection. If the appliance overheats, it switches off automatically. Unplug the appliance and let it cool down until room temperature. Then, put the mains plug back into the power outlet and switch on the appliance again. Please contact your Philips dealer or an authorized Philips service center if the overheat protection is activated too often. The appliance is also equipped with mechanical protection. To protect the motor, the plastic gear has been designed to break if bones or utensils are fed into the appliance. When this happens, simply remove the gear and exchange it.

Electromagnetic fields (EMF)

This Philips appliance complies with all standards regarding electromagnetic fields (EMF). If handled properly and according to the instructions in this user manual, the appliance is safe to use based on scientific evidence available today.

Recycling

Your product is designed and manufactured with high quality materials and components, which can be recycled and reused. When you see the crossed-out wheel bin symbol attached to a product, it means the product is covered by the European Directive 2002/96/EC. Never dispose of your product with other household waste. Please inform yourself about the local rules on the separate collection of electrical and electronic products. The correct disposal of your old product helps prevent potentially negative consequences on the environment and human health.

2 Introduction

Congratulations on your purchase and welcome to Philips! To fully benefit from the support that Philips offers, register your product at www.philips.com.

With this product, you can:

- mince meat
- make sausages
- make kebbe
- make cookies (HR2728 only)
- cut vegetables and grate cheese (HR2728, HR2729, HR2526 only)
- crush ice (HR2728 only)

Tip

- For more recipes, go to www.kitchen.philips.com.

3 What's in the box (Fig. 1)

| | |
|---|---|
| 1 Hopper release button Press and hold it when you remove the hopper. | 18 Cutter/Knife |
| 2 Motor unit | 14 Sausage horns • A: Large sausage horn (diameter of 22 mm) • B: Small sausage horn (diameter of 12 mm) |
| 3 O / I Switch off or on the appliance. | 15 Sausage separator |
| 4 R (Reverse) Switch it to reverse the motor (only active when the O / I switch is in the "O" position) Release it to stop the motor reverse. | 16 Kebbe maker • A: Kebbe separator • B: Kebbe shaper |
| 5 Power cord | 17 Cookie maker (for HR2727 WEU and HR2728) • A: Cookie separator • B: Cookie shaper |
| 6 Feeding tray | 18 Pusher for the plastic hopper (HR2728, HR2729, HR2526 only) |
| 7 Pusher for the metal hopper | 19 Plastic hopper (HR2728, HR2729, HR2526 only) |
| 8 Metal hopper | 20 Metal drums (HR2728, HR2729, HR2526 only) • A: Coarse grater drum • B: Fine grater drum • C: Slicer drum • D: Ice drum (HR2728 only) |
| 9 Extra gear for the worm shaft | 21 Dust cover (HR2726, HR2727, HR2728, HR2526 only) |
| 10 Worm shaft | 22 Accessories tray (HR2726, HR2727, HR2526 only) |
| 11 Screw ring | 23 Accessories tray (for HR2728) |
| 12 Grinding discs • A: Coarse grinding disc (diameter of 8 mm) • B: Fine grinding disc (diameter of 5 mm) | 24 Innovative cleaning tool |

4 Mince meat

Before you use the appliance for the first time, thoroughly clean the parts that come into contact with food. Before you start, make sure you assemble according to Fig. 2-1. For disassembly, refer to Fig. 3-1.

Mince meat (Fig. 10-1)

Note

- Never grind bones, nuts, or other hard items.
- Never use frozen meat! Before you grind the meat, defrost it first.
- Do not overload the appliance by pushing too much meat into the hopper.
- You can select the appropriate grinding disc for the preferred granularity of minced meat. You can also grind more than once for finer texture.

Tip

- Remove bones, gristle, and sinews out of the meat as much as possible.
- Before you make sausages, mince the meat first (refer to "Make sausages").
- If the hopper is stuck, switch off the appliance and then switch it to Reverse mode to clear the stuck stuff.

5 Make sausages

Before you use the appliance for the first time, thoroughly clean the parts that come into contact with food.

Before you start, make sure you assemble according to Fig. 2-2.

For disassembly, refer to Fig. 3-2.

Make sausages (Fig. 10-2)

Note

- Make sure that the projections on the hopper align with the notches of the motor.
- Do not block the air outlet grooves of the sausage horn.
- Do not make the sausages too thick in case the sausage skin is overstretched.
- Keep the sausage skin wet to prevent it from sticking on the sausage horn.

Recipe

Sausages

- Ingredients:**
- 4500 g ground pork
 - 5 Tbsp. of salt
 - 1 Tbsp. of ground white pepper
 - 2 Tbsp. of rubbed sage
 - 1 tsp. of ginger
 - 1 Tbsp. of nutmeg
 - 1 Tbsp. of thyme
 - 470 ml ice water
 - 1 Tbsp. of ground hot red pepper
- Directions:**
- Mince the meat with the coarse grinding disc.
 - Thoroughly mix the minced meat and other ingredients.
 - Follow the instructions above to make your own sausages.

6 Make kebbe

Before you use the appliance for the first time, thoroughly clean the parts that come into contact with food.

Before you start, make sure you assemble according to Fig. 2-3.

For disassembly, refer to Fig. 3-3.

Make kebbe (Fig. 10-3)

Recipe

Kebbe

Yield: 5-8 servings

- Ingredients:**
- Outer casing**
 - 500 g lamb or fat-free mutton, cut into strips
 - 500 g bulgur wheat, washed and drained
 - 1 small onion
 - Filling**
 - 400 g lamb, cut into strips
 - 15 ml oil
 - 2 medium onions, finely chopped
 - 5-10 ml ground allspice
 - 15 ml plain flour
 - salt and pepper
- Directions:**
- Outer casing
 - Mince the meat, wheat, and onion together with the fine grinding disc.
 - Thoroughly mix the minced ingredients, and then mince the mixture twice again.
 - Use the kebbe maker to shape the mixture into kebbe casing.

Filling

- Mince the meat with the fine grinding disc.
- Fry the onion chops until they turn golden brown.
- Add the minced meat and other ingredients in, and then cook for 1-2 minutes.
- Drain off excessive fat and cool the filling down.

Cooking

- Push some filling into the outer casing, and then pinch both ends to seal it.
- Heat the oil for deep frying (190°C).
- Deep fry the kebbe for 3-4 minutes, or until it turns golden brown.

7 Make cookies (for HR2727 WEU and HR2728)

Before you use the appliance for the first time, thoroughly clean the parts that come into contact with food.

Before you start, make sure you assemble according to Fig. 2-4.

For disassembly, refer to Fig. 3-4.

Make cookies (Fig. 10-4)

Tip

- Align different holes of the cookie shaper with the hole on the cookie separator to make cookies of different shapes.

8 Cut vegetables (HR2728, HR2729, HR2526 only) and crush ice (HR2728 only)

Before you use the appliance for the first time, thoroughly clean the parts that come into contact with food.

Before you start, make sure you assemble according to Fig. 2-5.

For disassembly, refer to Fig. 3-5.

Fig. 4 indicates the foods that each drum is applicable to and the cutting shapes.

Note

- Only use the plastic hopper in combination with the metal drums and the pusher for plastic hopper.
- Do not switch the appliance to Reverse mode when using the plastic hopper.

Tip

- You can also grate cheese.

Crush ice (HR2728 only)

- Switch on the appliance.
- Push the broken ice into the hopper.

9 Cleaning and maintenance (Fig. 5 and Fig. 6)

Before you use the appliance for the first time, thoroughly clean the parts that come into contact with food.

Before you remove accessories or clean the motor unit, switch off and unplug the appliance.

- Do not immerse the motor unit in water nor rinse it under the tap.
- Do not clean the metal parts in a dishwasher.
- Clean the main unit with a moist cloth.
- Pass pieces of bread through the cutter housing to remove any meat left.
- Wash removable parts with a soft brush in soapy water; rinse them with clear water, and then dry them with soft cloth or tissues immediately.
- Lightly brush the metal parts with fat or oil to prevent rusting.

Note

- Use the innovative cleaning tool to remove the remains stuck in the grinding discs; rinse them with clear water, and then dry them with soft cloth or tissues immediately.

10 Replace the gear (Fig. 7)

11 Store the appliance (Fig. 8 and Fig. 9)

