

Haloplate

黑晶爐

HD4415



PHILIPS

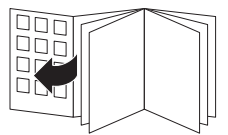

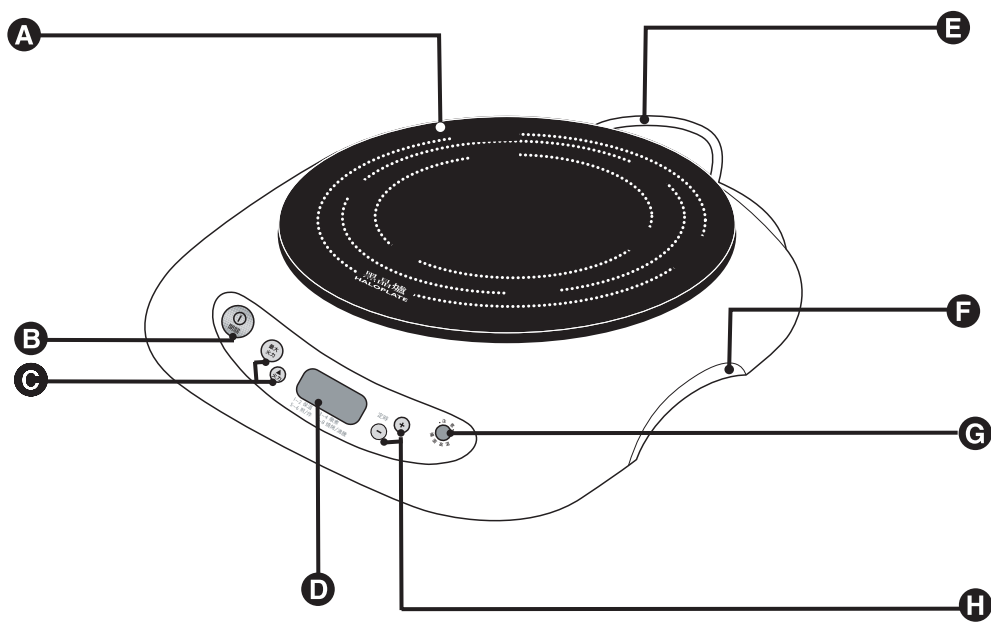



ENGLISH 6

繁體中文 12

General description

- A** Cooking plate
- B** On/off button
- C** Heating control
- D** Display
- E** Mains cord
- F** Carrying handle
- G** 'Plate hot' warning light
- H** Cooking timer

Important

Read these instructions for use carefully before using the appliance and save them for future reference.

- D** As the appliance largely works by means of heat radiation, virtually any type of pan can be used, e.g. glass, stainless steel, aluminium, ceramic, earthenware and non-stick coated pans. To achieve the best result, use pans with a flat base and a non-reflective outer surface to ensure highest efficiency in heat transmission.
- D** Check if the voltage indicated on the appliance corresponds to the local mains voltage before you connect the appliance.
- D** If the mains cord is damaged, it must be replaced by Philips, a service centre authorised by Philips or similarly qualified persons in order to avoid a hazard.
- D** Do not allow the mains cord to come into contact with the plate and the pan standing on the plate when they are hot.
- D** Never immerse the appliance in water or any other liquid.
- D** Leave a free space of about 10cm around the appliance to prevent damage due to radiated heat.
- D** Place the pan properly in the centre of the plate. Be careful: the handgrips of small pans may become hot.
- D** Do not put plastic containers or aluminium foil on the plate when it is hot.
- D** If you detect any cracks or fissures in the plate, stop using the appliance right away, unplug it and contact the nearest Philips service centre.
- D** Pans, especially cast-iron and enamel pans, may have ridges or burrs on the bottom that may cause scratches on the surface of the plate when the pan is moved.
- D** To prevent permanent marks from developing on the plate, make sure pans are dry on the outside before placing them on the plate. If water or anything else splashes onto the plate, wipe it off the plate immediately.
- D** Do not drop hard objects on the plate, as this may lead to breakage.
- D** Keep the hot appliance away from meltable and flammable materials.

- ▶ Keep the appliance out of the reach of children. Do not let the mains cord hang over the edge of the table or worktop on which the appliance is standing.
- ▶ Never let the appliance operate unattended.
- ▶ Do not cover the ventilation slots in the bottom and at the back of the appliance.
- ▶ Do not stare into the light emitted by the plate during operation.

Safety features

Automatic overheat protection

During cooking, the appliance will automatically reduce its heating level from 8 to 7, 6 or 5 if it becomes too hot. When this happens, the heating level shown on the display remains unchanged. After having cooled down sufficiently, the appliance will automatically heat up to the selected heating level again.

When the appliance has overheated due to a defect or misuse (e.g. covering of the ventilation slots), the appliance automatically switches off completely.

Automatic shut-off

The appliance switches off automatically after approximately 180 minutes.

'Plate hot' indication

- ▶ After you have switched the appliance off, the 'plate hot' warning light will continue to blink to indicate the cooking zone is still hot.

If you unplug the appliance while the warning light is blinking and then plug it in again, the warning light will not go on again.



Before first use

- ▶ Clean the appliance with a damp cloth and rub it dry before using the appliance for the first time.

Using the appliance

- 1 Put the plug in the wall socket.
The display goes on.

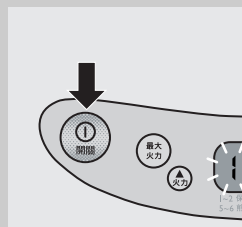

- 2** Press the on/off button once to put the appliance in standby position.

On the left side of the display a blinking '1' appears.

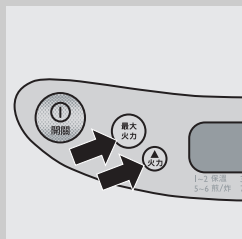

- 3** Set the required heating level by means of the POWER '最大火力' and '火力' buttons on the left side of the control panel.

- There are 8 heating levels. Level 1 represents minimum power, level 8 represents maximum power.
 - The selected heating level is shown on the left side of the display.
 - See section 'Tips' in this chapter for the recommended cooking settings.
- ▶ If you don't set the heating level within 30 seconds, the appliance will switch off automatically.

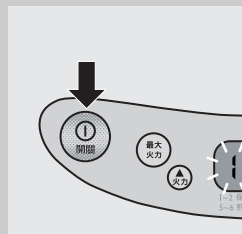

- ▶ The heating level can also be adjusted during use.

- 4** Press the on/off button after use to switch the appliance off.

- 5** Keep the appliance plugged in after use for at least 15 minutes to allow the fan to cool the appliance in a shorter period of time.

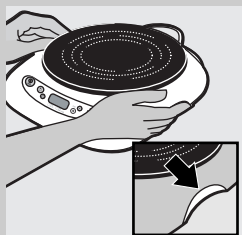

- ▶ Carry the appliance by its handles.

Timer

For extra comfort and safety, you can use the timer to set the desired cooking time. The appliance will switch off automatically when the set cooking time has elapsed.

You can set the timer before as well as after setting the heating level.

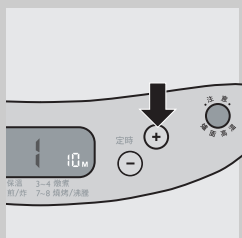

- 1** Set the timer by means of the TIMER + and – buttons on the right side of the control panel.

- The set time is shown on the right side of the display.
- Keep the button pressed to put the minutes forward quickly.
- The timer can be reset by keeping the – button pressed until the

display shows '0' or by pressing the on/off button twice.
 - The maximum time that can be set is 180 minutes.

2 Release the button once the required cooking time has been reached.

- The timer starts counting down as soon as you release the button, also when the heating level has not yet been set.
- During use, the remaining cooking time is shown on the display.

▶ The time can be adjusted during use.

3 When the preset time has elapsed, the appliance beeps and then switches off automatically. You can stop the audible signal by pressing the on/off button briefly.

During the beeping, the timer can be set again without interrupting the cooking process. Repeat steps 1 and 2 of this section.

▶ The cooking timer can also be used as a handy kitchen timer. Just make sure the appliance is plugged in and do not select a heating level.

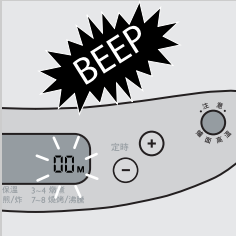

Tips

▶ As the appliance largely works by means of heat radiation, virtually any type of pan can be used, e.g. glass, stainless steel, aluminium, ceramic, earthenware and non-stick coated pans. To achieve the best result, use pans with a flat base and a non-reflective outer surface to ensure highest efficiency in heat transmission.

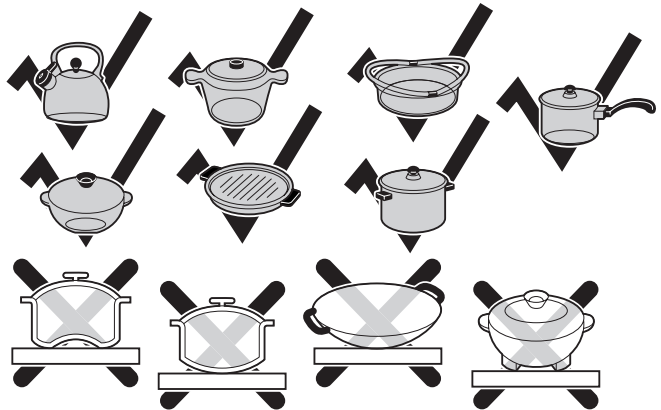

▶ When using glass pans, avoid thermal shock conditions: do not place a cold pan on a hot cooker or a hot pan on a cold cooker. Do not let glass pans boil dry.

► Advised cooking settings (for 110V performance)

Level	Temperature °C (approx. value)	Job
1	105	Keeping warm
2	150	Keeping warm
3	190	Stewing
4	245	Stewing
5	325	Stir frying/Deep frying
6	395	Stir frying/Deep frying
7	520	Grilling/Quick heating up, bringing to boil in the shortest time
8	700	Grilling/Quick heating up, bringing to boil in the shortest time

Cleaning

Regular cleaning will improve the performance of the appliance.

Never immerse the appliance in water.

Do not use any abrasive (liquid) cleaning agents or materials (e.g. scouring pads) to clean the appliance.



1 Unplug the appliance.

2 Remove (fat) splashes and spills, encrusted dirt or burned food when the plate is still warm.

Be careful! Make sure you don't touch the plate with your bare hands.

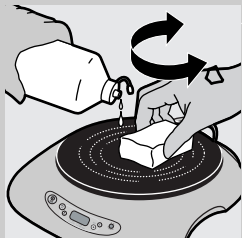

3 If necessary, apply a special cleaner for ceramic glass to the lukewarm surface of the cooking plate and rub lightly with a clean cloth or sponge.

4 Let the hot plate cool down completely.



5 Then clean the plastic surfaces with a moist cloth.

- ▶ Do not spill sugar on the cooking zone. Sugar and sugary foodstuffs (e.g. fruit syrups and marmalade) must be immediately removed from the hot plate so as to avoid chemical reactions.
- ▶ Bright brown stains showing up on the surface of the cooking plate are an indication of overheated scale. These stains develop on the plate as a result of spilled water or moist pans. When such discolourations are observed, the plate should be immediately cleaned with the cleaners mentioned above.
- ▶ Thicker layers of scale can only be removed by intensive cleaning, which may have to be repeated several times to be effective.
- ▶ Household items made of plastic (spoons, bowls, dishes, etc.) must on no account be placed on the hot cooking surface. The plastic will melt and stick to the hot surface. Should this occur, the surface is to be scraped clean at once while the plate is still hot.
- ▶ Do not use sponges or cloths which have already been used for other purposes.

Guarantee & service

If you need information or if you have a problem, please visit the Philips website at www.philips.com or contact the Philips Customer Care Centre in your country (you will find its phone number in the worldwide guarantee leaflet). If there is no Customer Care Centre in your country, turn to your local Philips dealer or contact the Service Department of Philips Domestic Appliances and Personal Care BV.

說明

- | | |
|----------------|-------------------|
| A 爐板 | E 電源線 |
| B 開關按鈕 | F 摺把 |
| C 火力控制鈕 | G 爐板高溫 警示燈 |
| D 液晶顯示 | H 烹煮定時器 |

重要說明

使用本產品前，請仔細閱讀本使用說明，並妥善保管以供未來參考。

- 在將黑晶爐連接電源之前，請檢查黑晶爐機體所標示的電壓與本地電源電壓是否相同。
- 電源線如果損壞，必須由 Philips 授權服務中心或類似的合格人員更換，以避免危險。
- 不要讓電源線接觸到高溫的爐板及黑晶爐上的鍋子。
- 不可將黑晶爐浸泡在水中或任何其他液體中。
- 黑晶爐的四周應保持約10cm 的空間以避免由於熱源而造成損壞。
- 將鍋子正確置於黑晶爐的中央。小心：小？鍋子的摺把可能會變得非常熱。
- 不要將塑膠容器或鋁箔放在高溫的爐板上。
- 如果您發現爐板有任何裂痕或裂縫，請立即停止使用，拔離黑晶爐的電源插頭，並與最近的飛利浦服務中心聯繫。
- 鍋子(尤其是鑄鐵及搪瓷鍋子) 的底部可能會有稜紋或毛邊，這可能會在鍋子移動時造成爐板表面刮傷。
- 為避免在爐板上形成永久印痕，在將鍋子放到爐板上之前，請確定鍋子的外側是否乾燥。如果水或任何其他物品噴濺到爐板上，請立即擦拭乾淨。
- 不要讓堅硬物品掉落到爐板上，因為這可能導致破裂。
- 黑晶爐在高溫時應遠離易熔或易燃物品。
- 不要讓兒童接觸黑晶爐。不要讓黑晶爐的電源線懸掛垂放在放置黑晶爐的桌子或流理台的邊緣。
- 操作黑晶爐時一定要有人看顧。
- 不要覆蓋黑晶爐底部及背面的通風孔。
- 在操作期間，不要注視黑晶爐所發出的光線。

安全功能

自動過熱保護

在烹煮期間，如果溫度變得過高，黑晶爐會自動將它的加熱等級從8 降低到 7、6 或 5。發生這種情況時，顯示器上顯示的加熱等級並不會改變。在冷卻到足夠的程度後，黑晶爐會再自動加熱到所選定的加熱等級。

當黑晶爐由於故障或不當使用(例如覆蓋通風孔)而過熱時,黑晶爐將會自動完全關閉。

自動關閉功能

在沒有操作的狀態下,黑晶爐會在約 180 分鐘後自動關閉。

'爐板高溫' 指示

- ▶ 在您将黑晶爐關閉後,'爐板高溫' 警示燈仍會繼續閃爍來表示烹煮區仍處於高溫狀態。

如果您在警示燈閃爍時拔離電源插頭然後再插上,警示燈將不會再次點亮。



第一次使用前的準備事項

- ▶ 在首次使用黑晶爐之前,請先用濕布清潔黑晶爐並將它擦乾。

使用本產品

- 1 將插頭插入牆壁插座。
顯示器亮起。

- 2 按一下 開關 按鈕讓黑晶爐進入備妥狀態。
接著在顯示器左側會出現閃爍的 '1' 字樣。

- 3 請利用控制面板左側的 火力 按鈕來設定所需的加熱等級。

- 共有 8 個加熱等級。第 1 級 表示最低功率,第 8 級 表示最大功率。
- 所選定的加熱等級會顯示在顯示器的左側。
- 關於建議的烹煮設定,請參閱本章中的'秘訣'一節。

- ▶ 如果您沒有在 30 秒之內設定加熱等級,黑晶爐將會自動關閉。

- ▶ 在使用期間也可以調整加熱等級。

- 4 在使用後請按 開關 按鈕來關閉黑晶爐。

- 5 使用黑晶爐之後要至少等15分鐘才可拔下插頭以使風扇能夠冷卻黑晶爐一段時間。

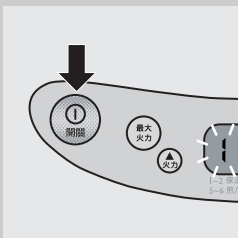
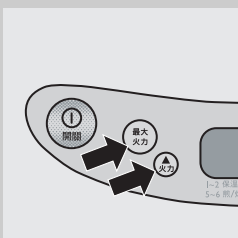
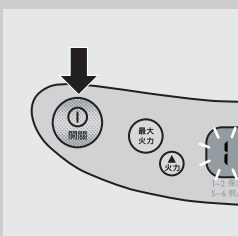

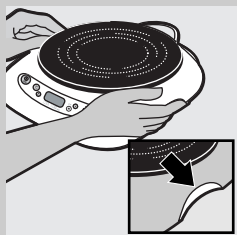

- ▶ 請利用把手提起黑晶爐。

定時器

為達到更大的便利及安全，您可以使用定時器來設定想要的烹煮時間。在設定的烹煮時間結束時，黑晶爐將會自動關閉。

在設定加熱等級之前及之後您都可以設定定時器。

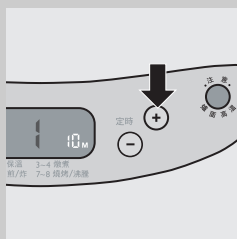

- 1** 請利用控制面板右側的「定時 +」及「-」按鈕來設定定時器。

- 設定的時間會顯示在顯示器的右側。
- 按住按鈕來加快分鐘數的跳動。
- 按住「-」按鈕直到顯示器顯示「0」或按兩下「開關」按鈕即可將定時器歸零。
- 可以設定的最長時間約 199 分鐘。

- 2** 在達到所需的烹煮時間時放開按鈕。

- 當您放開按鈕時，定時器就會開始倒數計時，即使您還沒有設定加熱等級。
- 使用期間，剩餘的烹煮時間會顯示在顯示器上。

- ▶ 時間也可以在使用期間調整。

- 3** 當預設的時間結束時，黑晶爐會發出嗶聲然後自動關閉。

您可以輕按一下「開關」按鈕的來停止聲音訊號。在嗶聲持續期間，可以再次設定定時器而不會中斷烹煮過程。重複本節所述的步驟1及2。



- ▶ 烹煮定時器也可以用來做為一般廚房用定時器。您只要確定黑晶爐有插接電源且沒有設定加熱等級即可。

秘訣

- 由於黑晶爐主要是利用鹵素燈管加熱來發揮作用，所以可以使用任何種類的鍋子，例如耐熱玻璃、不銹鋼、鋁、瓷、陶土、平底炒菜鍋以及烤盤等等。為達到最佳的效果，請使用平底且外側表面不反光的鍋具以確保最高的導熱效率。

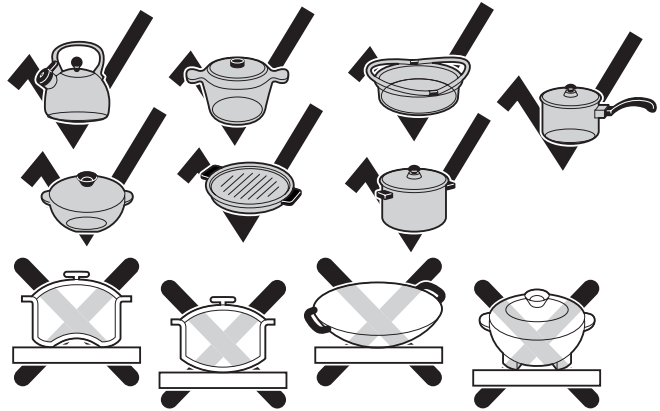

- 若使用玻璃盤時，請避免溫度急遽變化的情況：不要將冷的盤子放在高溫的爐具上，或者將高溫的盤子放在冷的爐具上。不要讓玻璃鍋子乾煮。
- 建議烹煮設定（110V 適用）：

等級	溫度 °C 大約值	烹煮模式
1	105	保溫
2	150	保溫
3	190	燉煮
4	245	燉煮
5	325	煎/炸
6	395	煎/炸
7	520	燒烤/沸騰
8	700	燒烤/沸騰

清理

定期清潔將可維護黑晶爐的性能。

切勿將本產品浸泡於水中。

不要使用任何有研磨性(液體)的清潔劑或材料(例如菜瓜布)來清潔黑晶爐。



1 將黑晶爐的插頭拔出。

2 請在爐板仍溫熱時清除噴濺的油脂、變硬的污垢、或燒焦的食材。

小心! 請確定不要徒手碰觸爐板。

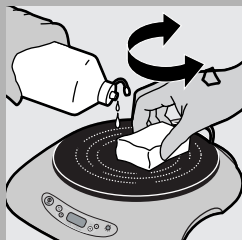

3 請視需要在微溫的爐板表面上塗抹一些廚房抽油煙機專用清潔劑並以乾淨的布輕輕擦拭。

4 請讓高溫的爐板完全冷卻下來。

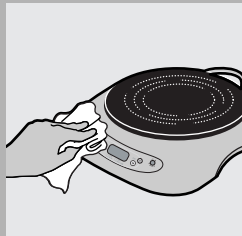

5 然後用濕布清潔塑膠表面。

- ▶ 不要讓糖分滴到烹煮區上。必須將高溫的爐板上的糖和含糖的食材(例如果糖和果醬)立即清除以避免發生化學反應。
- ▶ 爐板表面上出現的亮褐色汙漬表示過熱的汙垢。這些汙漬是因為水噴濺到爐板上或者鍋子潮濕所造成的。發現這樣的變色情形時,應立即以上述的廚房抽油煙機專用清潔劑清潔爐板。
- ▶ 較厚的汙垢必須要要密集的清潔將它去除,可能必須反覆清潔多次才能有效去除。
- ▶ 塑膠製成的餐具(如湯匙、碗盤等)絕對不可放置在高溫的烹煮表面上。否則塑膠會融化並黏在高溫表面上。如果發生這種情況,必須在爐板仍處於高溫狀態下立即刮除。
- ▶ 不要使用已經使用在其他用途上的抹布。

保固與服務

若您需要相關資訊或有任何問題,請瀏覽飛利浦位於 www.philips.com 的網站,或連絡您當地飛利浦客戶服務中心(您可以在全球保證書上找到連絡電話)。如果您當地沒有客戶服務中心,請洽當地飛利浦經銷商或與飛利浦小家電服務部門連絡。







